

# PRESS BRAKE TOOLING AND EQUIPMENT

UTENSILI E ATTREZZATURE  
PER PRESSE PIEGATRICI



VERSIONE 05 - VERSION 05





# EUROSTAMP TOOLING

the Italian excellence

---

**Eurostamp Tooling significa qualità,  
competenza e precisione.**

Dal 1970 produciamo utensili e attrezzature per la piegatura straordinariamente precisi, offrendo soluzioni di estrema qualità per tutti quei clienti che richiedono costantemente massimi livelli di performance e affidabilità.

***Eurostamp Tooling means quality,  
competence, accuracy.***

*Since 1970 we have been manufacturing outstandingly accurate tooling and providing top quality solutions to all those customers who require the highest levels of performance and reliability.*

Eurostamp Tooling,  
the Italian Excellence

# CHI SIAMO

L'azienda è stata creata nel 1970 e, sin da allora, siamo orgogliosi di produrre e commercializzare utensili e attrezzature per la piegatura altamente performanti, affidabili e caratterizzati dai più elevati standard di qualità. Il nostro parco macchine utensili a elevata tecnologia e il magazzino con ampia disponibilità ci permettono di soddisfare ogni esigenza e richiesta speciale.

I nostri utensili sono realizzati con acciai al carbonio e acciai speciali di provenienza italiana, con tempra a induzione sulle parti usurabili che ne garantisce una durezza di 55-60 HRC.

Offriamo un'ampia gamma di accessori per presse piegatrici: adattatori inferiori e superiori, sistemi di bloccaggio manuali e pneumatici.

Il nostro ufficio tecnico interno, inoltre, è in grado di studiare i progetti di piegatura personalizzati in modo tempestivo e accurato.

---

# WHO WE ARE

*Our company was born in 1970 and, since then, we have been proudly producing and marketing high performing and reliable press brake tooling distinguished by the highest quality standards. Our production department equipped with high-tech machine tools, complimented by our wide range inventory, allows us to meet our customer needs and expectations for standard and special tool requirements.*

*Our tooling is produced by using medium carbon steel C45, both raw and tempered, and Italian high-quality chrome molybdenum steel.*

*All our tooling is then hardened by induction (HRC 55-60) up to 3mm depth from the working surface. In addition to providing high quality Press Brake Tooling, we also provide a large range of accessories for press brakes: lower and upper adaptors, manual or pneumatic clamping systems and more.*

*Our in-house technical department have the knowledge, experience, and expertise to develop fully tailored bending projects in a timely and accurate manner.*

# LA NOSTRA FILOSOFIA

Eurostamp Tooling è un'azienda con cuore italiano e anima internazionale; abbiamo deciso di concentrarci e specializzarci esclusivamente nella produzione e sviluppo degli utensili di piegatura, settore in cui abbiamo sviluppato la più alta tecnologia applicata a ciascuno dei processi interni.

Il nostro reparto produttivo pone la massima attenzione alla cura dei dettagli, alla precisione e all'accurato controllo della qualità con una ispirazione artigianale: selezioniamo i migliori fornitori italiani di materia prima, e investiamo costantemente in attrezzature di qualità e in spazi di stoccaggio di ampio respiro. Poniamo una fortissima attenzione alla formazione dello staff tecnico e produttivo ed investiamo costantemente in ricerca e sviluppo perché crediamo fortemente che il modo migliore per soddisfare i nostri clienti sia il superamento delle loro aspettative con soluzioni innovative e un supporto pre e post vendita di elevato livello. Il team commerciale lavora quotidianamente a fianco dello staff tecnico e produttivo per diffondere ovunque la nostra filosofia di marchio.

# OUR PHILOSOPHY

*Eurostamp tooling is an Italian company with an international "soul". Since the beginning we chose to focus all of our attention only on the engineering and manufacturing of press brake tooling, so we invested our resources on the state-of-art technologies applied to each of our internal processes.*

*Our production department takes great care to every detail, to the highest precision and to the accurate quality control. We are cooperating with the best raw material suppliers among the Italian market and we are constantly investing in new production technologies. Our finished product is then stocked in our wide and organized warehouse, ready for being handled by our skilled logistic resources. We put the highest care to the training of our production and engineering staff and to our policy of research and development because we are aware that this is the best way for overcoming our customer expectations with innovative solutions and with the highest level of pre- and post-sales support. Our sales staff is working daily beside our production and our engineering departments with the mission to spread worldwide our brand philosophy.*



# LE COMPETENZE

Gli specialisti che compongono il nostro staff controllano ogni fase produttiva, dalla scelta delle leghe e degli acciai grezzi, alle procedure di fresatura, tempra e rettifica di ogni pezzo. Usiamo acciaio al 100% italiano per garantire massima precisione e caratteristiche meccaniche ad alto standard qualitativo.

# OUR COMPETENCES

*Our specialized staff takes care of each production phase, from choosing the best kind of steel to the procedures for machining, hardening and grinding each product with the best results. We are utilizing only 100% Italian source steel for granting always the conformity to the most severe standards specifications.*

# CALCOLO DELLA FORZA DI PIEGA IN ARIA AIR BENDING FORCE CALCULATION

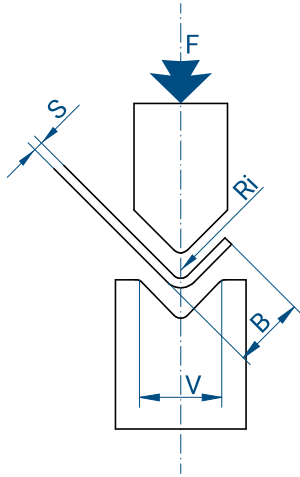

<b>S</b>	Spessore lamiera - mm Sheet metal thickness - mm	<b>Ri</b>	Raggio interno Inside radius
<b>V</b>	Larghezza del V V-opening	<b>R</b>	Alluminio 20-25 kg/mm <sup>2</sup> Aluminium 20-25 kg/mm <sup>2</sup>
<b>F</b>	Forza in T/m Force in T/m	<b>R</b>	Acciaio dolce 40-45 kg/mm <sup>2</sup> Mild steel 40-45 kg/mm <sup>2</sup>
<b>B</b>	Bordo minimo Shortest edge	<b>R</b>	Inox 65-70 kg/mm <sup>2</sup> Stainless steel 65-70 kg/mm <sup>2</sup>

$$F = \frac{S^2 \times 2 \times R}{1.4 \times V} = \dots \text{ ton/m}$$

## RELAZIONE TRA SPESSORE LAMIERA E LARGHEZZA V SHEET METAL THICKNESS / V-SHAPE WIDTH RATIO

<b>S</b>	Spessore lamiera - mm Sheet metal thickness - mm	0,5-2,5	3-8	9-10	12 o più 12 or more
<b>V</b>	Larghezza del V "V" width	6 S	8 S	10 S	12 S

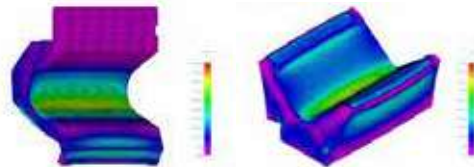

### TABELLA DI PIEGATURA IN ARIA - ACCIAIO DOLCE AIR BENDING TABLE - MILD STEEL

<b>S</b>	mm	0,5	0,6	0,8	1	1,2	1,5	2	2,5	3	4	4,5	5	6	8	10	12	15	20	25	30	
6	4	1		3	4	7	11															
8	5,5	1,3		4	5	8	12	20														
10	7	1,6		4	7	10	17															
12	8,5	2			6	8	15	22														
14	10	2,3				7	13	19														
16	11	2,6				6	11	17	28													
18	13,5	3					10	15	25	34												
20	14	3,3					9	13	22	30												
25	17,5	4						11	18	24	43											
32	22	5							14	19	34	44	52									
40	28	6,5								15	27	34	42	60	107							
50	35	8									21	27	33	48	85							
63	45	10										17	21	26	38	68	105					
80	55	13											21	30	53	85	120					
100	71	16												24	43	67	96	150				
125	89	20													53	78	120	215				
160	113	26														42	60	95	170			
200	140	33															55	75	135	210		
250	175	41																108	170	240		
V	B	Ri																			<b>F</b>	t/m

### TABELLA DI PIEGATURA IN ARIA - ACCIAIO INOX AIR BENDING TABLE - STAINLESS STEEL

<b>S</b>	mm	0,5	0,6	0,8	0,9	1	1,2	1,5	2	2,5	3	4	5	6	8	10	12	15	20	25	30					
6	4	1				5	6	11	13	17																
8	5,5	1,3					6	8	10	12	18															
10	7	1,6						7	8	11	15															
12	8,5	2							7	8	12	20	33													
14	10	2,3								11	17	29														
16	11	2,6									9	15	26	39												
18	13,5	3										13	23	35	51											
20	14	3,3											12	20	30	45										
25	17,5	4												17	25	36	65									
32	22	5													19	29	51	78								
40	28	6,5														23	41	63	90							
50	35	8															32	50	72	208						
63	45	10																26	39	57	102	163				
80	55	13																	32	45	81	129	187			
100	71	16																		36	65	101	144			
125	89	20																			51	80	117	180		
160	113	26																				63	90	141	250	
200	140	33																					83	114	208	315
250	175	41																						167	255	360
V	B	Ri																							<b>F</b>	t/m



# INDICE PRODOTTI

## PRODUCT INDEX

CODICE/CODE	PAGINA/PAGE	CODICE/CODE	PAGINA/PAGE	CODICE/CODE	PAGINA/PAGE	CODICE/CODE	PAGINA/PAGE
1011	18	1084	23	1162	30	1249	143
1011S	17	1086	37	1163	30	1250	144
1012	18	1090	192	1171	27	1251	145
1014	20	1091	193	1172	27	1252	189
1015	21	1096	192	1173	22	1253	188
1017	22	1100	197	1175	20	1254	188
1018	22	1101	197	1177	26	1260	26
1020	20	1102	197	1178	38	1262	20
1022	24	1103	197	1180	196	1264	19
1023	24	1104	197	1181	196	1266	21
1024	33	1106	198	1182	196	1268	22
1025	33	1107	198	1183	196	1270	23
1026	29	1108	198	1184	196	1271	31
1027	29	1109	198	1185	196	1272	31
1029	19	1110	199	1186	196	1273	193
1030	24	1111	199	1187	196	1274	206
1031	23	1112	199	1190	30	1275	206
1032	31	1113	199	1191	30	1276	206
1033	38	1114	200	1192	38	1277	206
1034	34	1115	200	1193	35	1278	209
1035	34	1116	201	1194	35	1279	209
1036	192	1117	201	1195	75	1280	209
1037	197	1118	201	1196	75	1281	26
1038	198	1130	205	1197	76	1282	34
1039	199	1131	205	1198	203	1283	31
1040	199	1132	205	1216	177	1284	32
1041	200	1133	205	1218	177	1289	35
1042	200	1134	206	1220	179	1290	24
1043	202	1135	206	1221	180	1291	25
1047	34	1136	206	1225	179	1292	37
1047S	17	1137	206	1227	174	1293	32
1049	19	1138	207	1229	174	1294	98
1052	36	1139	207	1230	175	1295	104
1053	33	1140	207	1231	175	1296	195
1055	36	1141	207	1232	175	1297	195
1056	35	1142	208	1233	99	1298	176
1057	36	1143	208	1234	101	1299	178
1061	21	1144	208	1235	100	1300	178
1062	21	1145	208	1236	103	1301	25
1063	18	1146	208	1237	105	1302	104
1065	18	1147	208	1238	105	1303	102
1065S	17	1148	208	1239	193	1305	194
1081	19	1150	203	1240	194	1306	194
1082	23	1155	195	1242	203	1308	106

CODICE/CODE	PAGINA/PAGE	CODICE/CODE	PAGINA/PAGE	CODICE/CODE	PAGINA/PAGE	CODICE/CODE	PAGINA/PAGE
1309	28	1345	84	2053	46	3016	56
1310	28	1346	84	2054	46	3017	56
1311	38	1347	85	2055	46	3018	56
1312	28	1348	85	2056	47	3019	58
1313	106	1349	85	2058	43	3020	58
1314	100	2013	44	2059	43	3021	58
1315	98	2014	44	2060	43	3022	58
1316	107	2015	45	2067	48	3023	58
1317	101	2016	45	2081	53	3024	58
1318	103	2017	45	2082	52	3025	58
1319	102	2018	42	2083	52	3026	59
1320	99	2019	42	2084	54	3027	59
1321	177	2020	49	2086	54	3028	59
1322	28	2021	49	2087	54	3029	59
1323	150	2022	49	2088	53	3030	59
1324	150	2023	49	2089	52	3031	59
1325	156	2024	49	2101	212	3032	59
1326	155	2025	50	2102	212	3037/6	73
1327	155	2026	50	2103	212	3037/8	73
1328	150	2027	50	2104	212	3038	72
1329	152	2030	48	2105	212	3038PN	74
1330	152	2031	47	2106	212	3039	73
1331	153	2032	44	2107	212	3039PN	74
1332	151	2033	45	2108	212	3040	72
1333	151	2034	48	2109	210	3040PN	74
1334	154	2035	42	2110	210	3041	72
1335	154	2036	211	2111	210	3041PN	74
1336	154	2037	211	2112	210	3042	60
1337	156	2038	211	2113	210	3043	60
1338	29	2039	42	2114	210	3044	60
1339	29	2040	211	2115	210	3045	60
1340	83	2041	44	2116	210	3046	60
1341	83	2046	44	2117	53	3047	60
1342	83	2047	45	2118	53	3048	60
1343	83	2050	46	2119	211	3055	61
1344	84	2052	46	3015	56	3056	61

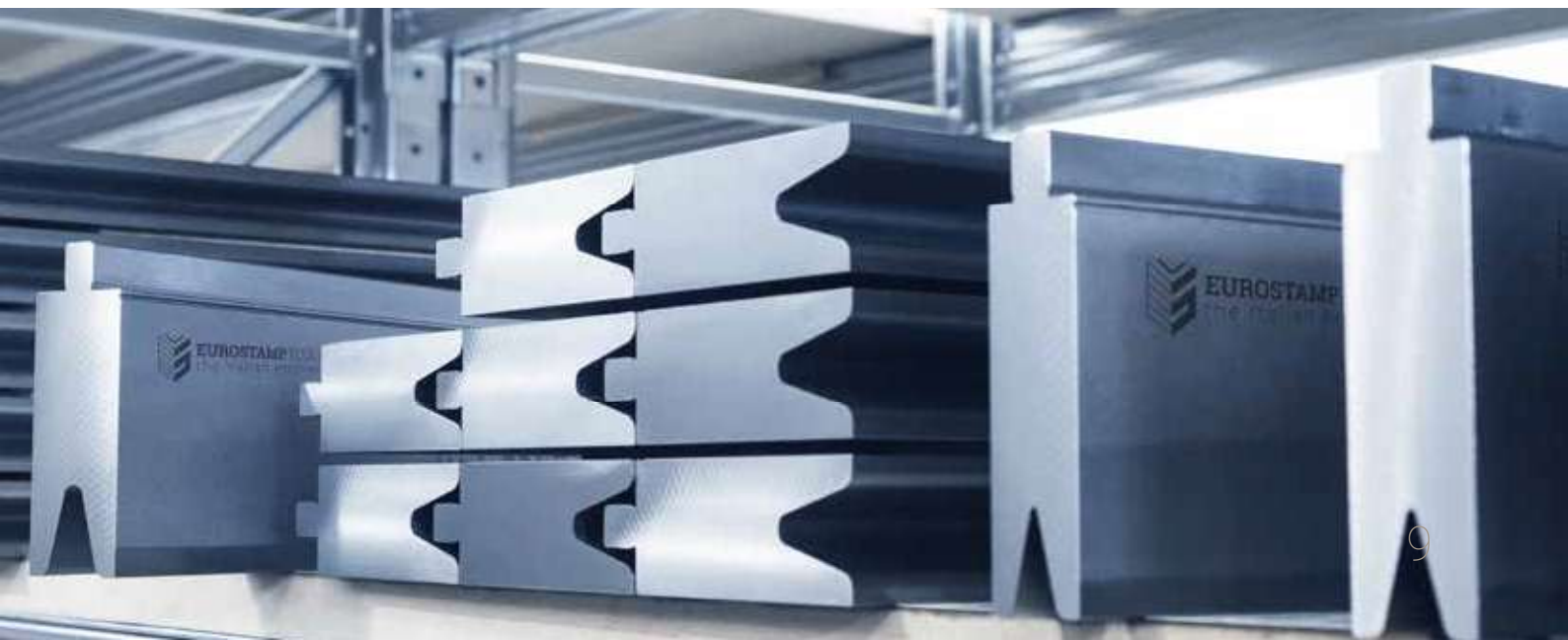

CODICE/CODE	PAGINA/PAGE	CODICE/CODE	PAGINA/PAGE	CODICE/CODE	PAGINA/PAGE	CODICE/CODE	PAGINA/PAGE
3057	61	3093	62	3135	133	3171	70
3058	61	3094	62	3136	134	3172	70
3059	63	3095	62	3137	134	3173	66 - 86
3060	63	3096	62	3138	134	3174	144
3061	63	3097	62	3139	134	3175	145
3062	63	3098	62	3140	135	3176	75
3063	63	3099	62	3141	135	3177	75
3064	63	3106	182	3142	135	3178	76
3065	63	3107	183	3143	136	3179	185
3066	64	3108	183	3144	136	3190	251
3067	64	3109	183	3145	137	3191	251
3068	64	3110	183	3146	137	3192	252
3069	64	3111	184	3147	137	3193	69
3070	64	3112	184	3148	137	3194	69
3071	64	3113	185	3149	138	3195	69
3072	64	3114	185	3150	138	3196	69
3073	65	3115	186	3151	138	3197	69
3074	65	3116	186	3152	139	3198	69
3075	65	3117	186	3153	139	3199	69
3076	65	3118	187	3154	139	3200	116
3077	65	3119	187	3155	139	3201	116
3078	65	3120	187	3156	140	3202	116
3079	65	3121	187	3157	143	3203	116
3080	56	3122	187	3158	68	3204	117
3081	56	3123	130	3159	68	3205	117
3082	56	3124	130	3160	68	3206	125
3083	61	3125	130	3161	68	3207	125
3084	61	3126	130	3162	68	3208	125
3085	61	3127	131	3163	68	3209	125
3086	57	3128	131	3164	68	3210	126
3087	57	3129	131	3165	68	3211	126
3088	57	3130	131	3166	70	3212	126
3089	57	3131	132	3167	70	3213	126
3090	57	3132	132	3168	70	3214	127
3091	57	3133	132	3169	70	3215	117
3092	57	3134	133	3170	70	3216	117



<b>CODICE/CODE</b>	<b>PAGINA/PAGE</b>	<b>CODICE/CODE</b>	<b>PAGINA/PAGE</b>	<b>CODICE/CODE</b>	<b>PAGINA/PAGE</b>	<b>CODICE/CODE</b>	<b>PAGINA/PAGE</b>
3217	118	3262	168	4008	240	4222	235
3218	118	3263	169	4009	238	4223	235
3219	122	3264	169	4010	256	4224	235
3220	122	3265	169	4011	256	4225	235
3221	123	3270	160	4012	256	4226	236
3222	123	3271	160	4013	256	4227	236
3223	124	3272	160	4014	256	4228	236
3224	124	3273	161	4015	256	4229	245
3225	118	3274	161	4016	237	4272	245
3226	118	3275	161	4020	237	4273	245
3227	119	3276	164	4021	238	4274	202
3228	119	3280	165	4031	241	4275	195
3229	119	3281	165	4032	241	4277	42
3230	120	3282	165	4033	247	4281	239
3231	120	3283	166	4034	247	4282	236
3232	120	3284	166	4040	247	4301	246
3233	121	3285	167	4041	247	4302	246
3234	121	3286	167	4050	247	4303	246
3235	127	3320	87	4073	235	4304	246
3236	128	3321	87	4090	240	4305	246
3237	128	3322	87	4143	243	4306	256
3238	128	3323	87	4144	243	4307	256
3239	128	3324	87	4145	243	4308	254
3240	129	3325	88	4146	243	4309	254
3241	182	3326	88	4191	243	4313	74
3242	182	3327	88	4192	243	4314	254
3243	252	3328	88	4193	244	4318	257
3244	119	3329	88	4199	239	4319	257
3250	162	3330	89	4214	244	4330	141
3251	162	3331	89	4215	244	4349	239
3252	162	3332	89	4216	244	4361	245
3253	163	3333	89	4217	244	4362	245
3254	163	4000	242	4218	244	4379	254
3255	163	4001	242	4219	239	4380	254
3260	168	4002	242	4220	239	4384	258
3261	168	4007	240	4221	235	4381	234



CODICE/CODE	PAGINA/PAGE	CODICE/CODE	PAGINA/PAGE	CODICE/CODE	PAGINA/PAGE	CODICE/CODE	PAGINA/PAGE
4389	219	4414	224	8100	249	8216	108
4390	221	4419	223	8101	249	8218	108
4392	228	4883	257	8102	249	8219	108
4393	225	5011	238	8106	250	9010	248
4394	233	5012	237	8107	249	9011	248
4395	234	5013	237	8201	269	9012	248
4396	234	7290	51	8202	269	9013	248
4397	234	8010	249	8204	108	9014	253
4398	231	8011	249	8205	269	9015	253
4399	230	8012	249	8206	108	9016	253
4400	222	8013	249	8207	108	9017	253
4404	226	8014	250	8210	108	9018	253
4405	229	8016	250	8211	108	9019	253
4408	226	8017	250	8212	108	9020	248
4409	220	8020	250	8213	108	ACARMONE0005	260
4410	232	8021	250	8214	108	ACARM1NE0005	260
4411	236	8022	250	8215	108	ACARM2NE0005	260
						CARRELLO0005	260







**EUROSTAMP** TOOLING  
the Italian excellence

# AMADA PROMECAM STYLE EUROPEAN STYLE

**Gli utensili superiori ed inferiori elencati in questa sezione possono essere installati sulle piegatrici:**

ACL, Accurpress, AM Machinery, Amada, Atlantic, Adira, Baykal, BL, Boschert, Boutillon, Bystronic-Beyeler Euro-B, Coastone, Colgar, Dener, Deratech, Durmazlar, Ermaksan, Farina, Gade, Gasparini, Gizelis, Haco, Hindustan, Iturrospe, Jfy, JMT, LFK, Metfab, MVD, Oriance, Prima Power, Promecam, Rico, RPC Piegatrici, Salvagnini, Schiavi, SMD, Sorg, Somo, Vicla, Vimercati, Warcom, Yangli, Yawei, Ysde su tutte le piegatrici equipaggiate con sistemi di bloccaggio stile Europeo (stile Amada/Promecam).

Questi utensili possono essere installati anche su altre piegatrici tramite adattatori superiori e inferiori.

***Upper and lower tooling listed on this section could be installed on the following press brakes:***

*ACL, Accurpress, AM Machinery, Amada, Atlantic, Adira, Baykal, BL, Boschert, Boutillon, Bystronic-Beyeler Euro-B, Coastone, Colgar, Dener, Deratech, Durmazlar, Ermaksan, Farina, Gade, Gasparini, Gizelis, Haco, Hindustan, Iturrospe, Jfy, JMT, LFK, Metfab, MVD, Oriance, Prima Power, Promecam, Rico, RPC Piegatrici, Salvagnini, Schiavi, SMD, Sorg, Somo, Vicla, Vimercati, Warcom, Yangli, Yawei, Ysd, on all folders equipped with European-style clamping systems (Amada/Promecam style).*

*These tooling could also be installed on other press brakes by using the appropriate upper and lower adapters.*





VEDI PAG. 40 PER SCHEMA FRAZIONATURA MATRICI  
SEE PAGE 40 FOR DIE SEGMENTATION DIAGRAM

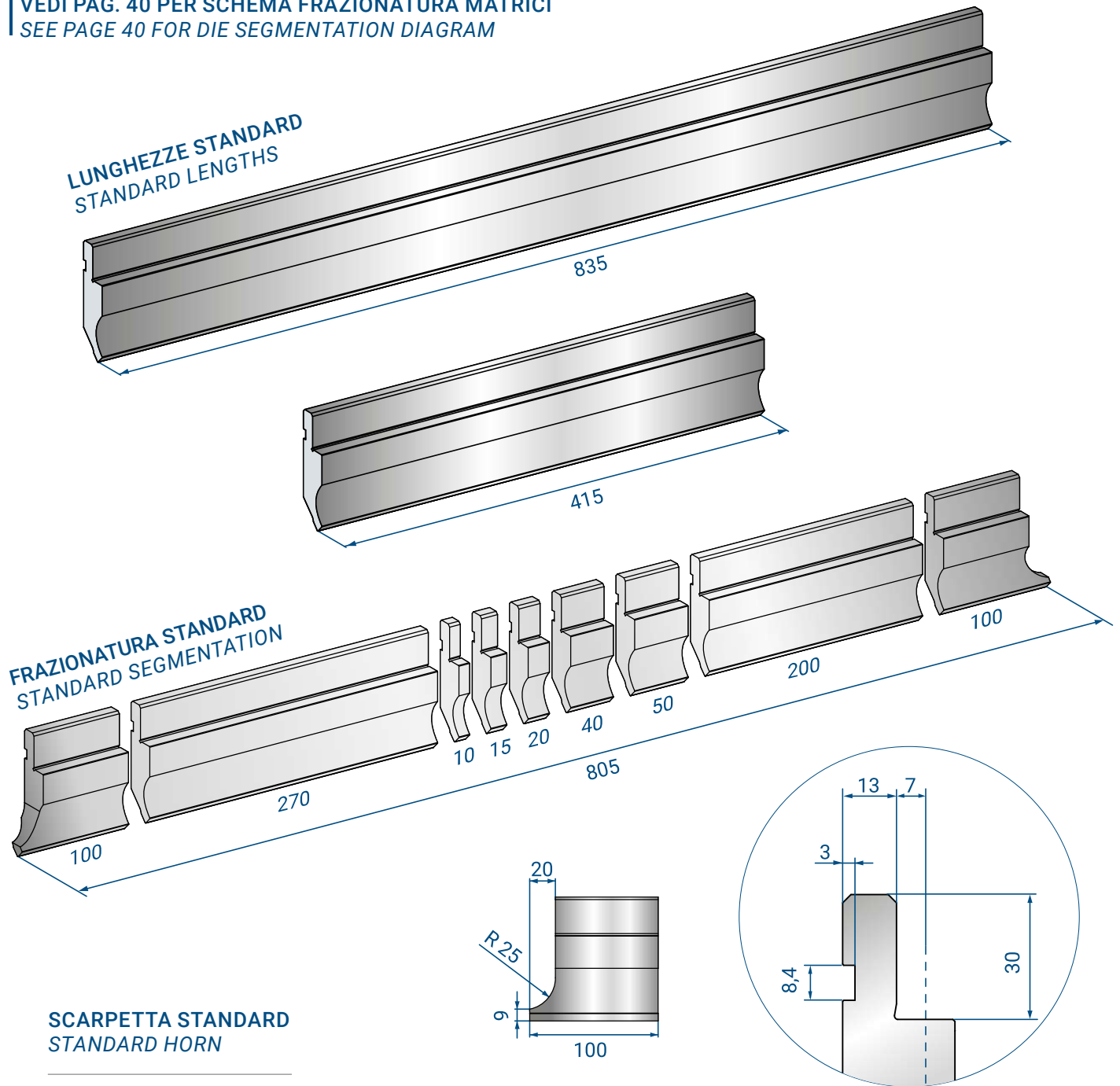

**MODIFICHE A RICHIESTA / MODIFICATIONS ON REQUEST**

**SCARPETTE SPECIALI**  
SPECIAL HORNS

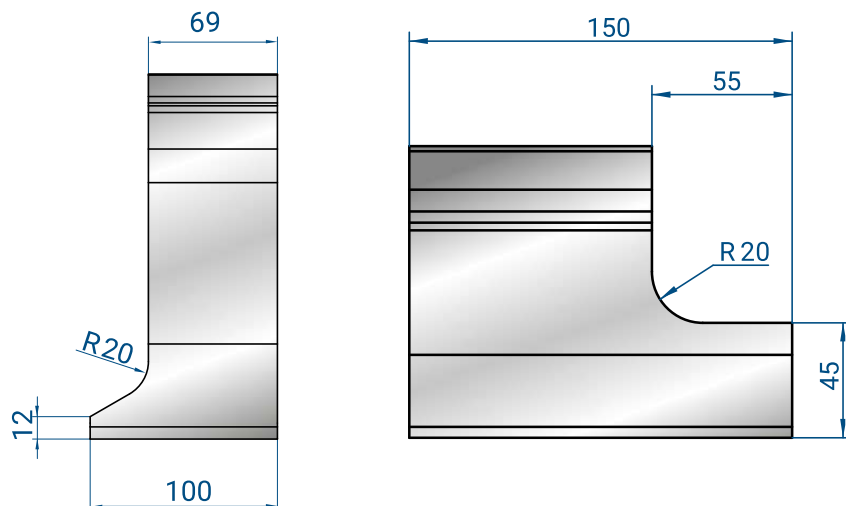

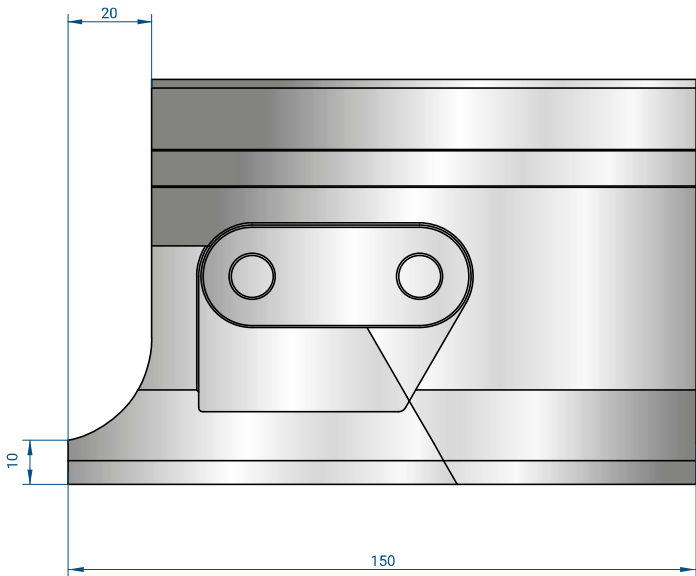

PUNZONE  
PUNCH

**1011 1011S**  
2x150 3,5 kg

SCARPETTE MOBILI  
MOVING HORNS

**1065 1065S**  
2x150 3,5 kg

**1047 1047S**  
2x150 4,0 kg

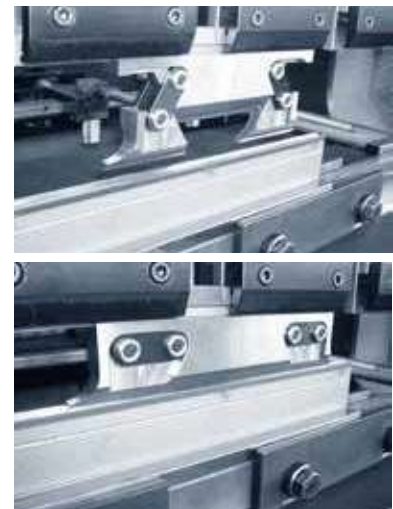
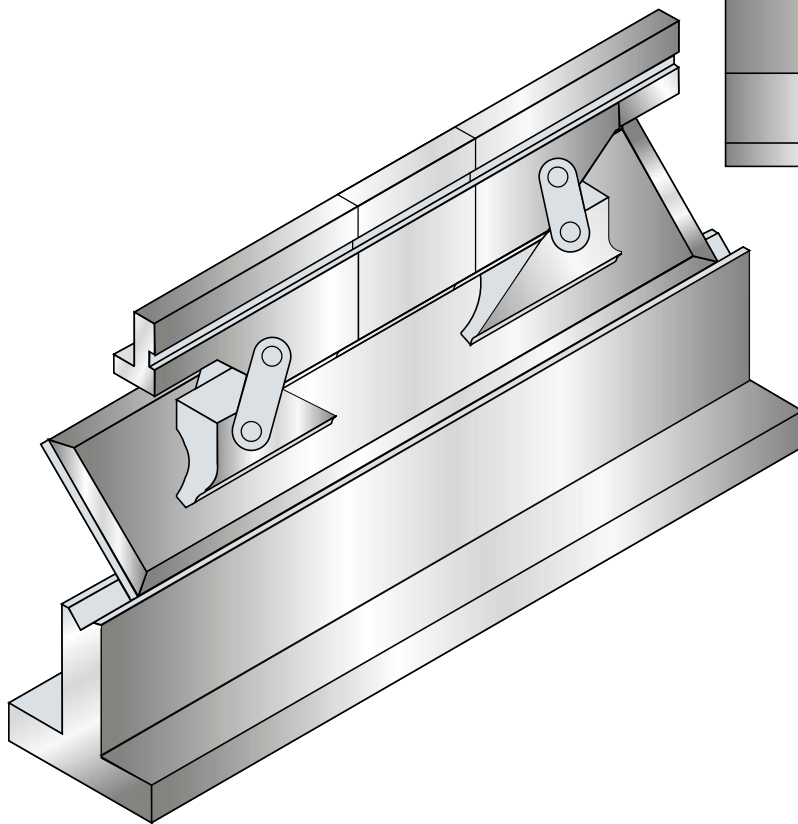
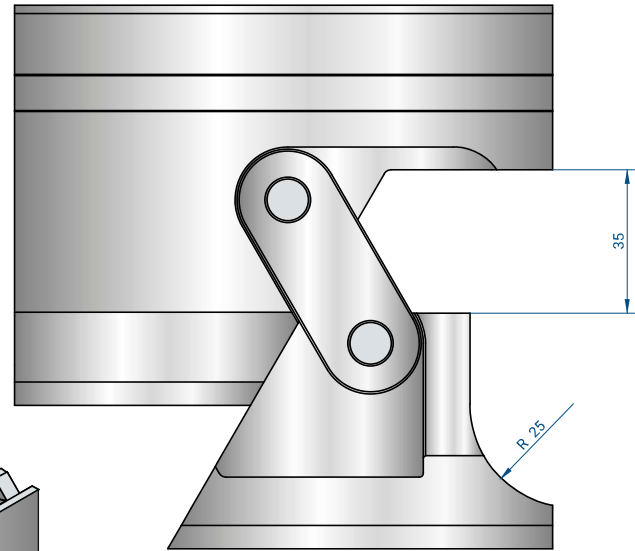

TAGLI A RICHIESTA  
SPECIAL SEGMENTATION



MODIFICA RAGGIO  
RADIUS MODIFICATION

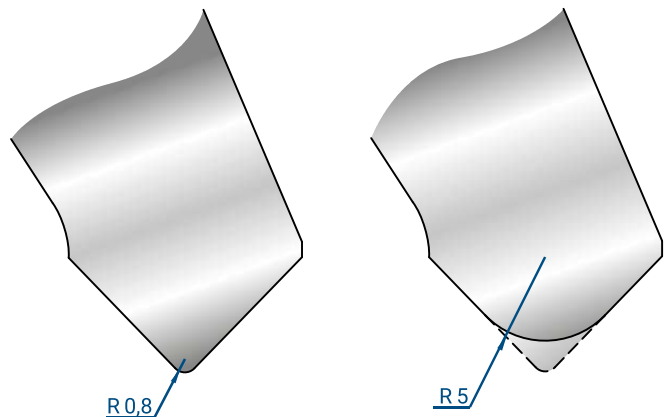

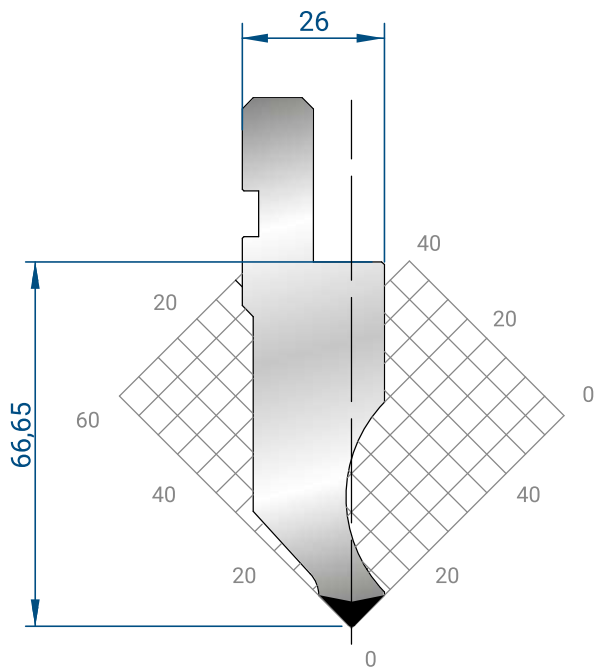

### 1011

Mat = C45  
 H = 66.65  
 Max T/m = 100  
 $\alpha = 88^\circ$   
 R = 0.8

835 mm	10,5 kg
415 mm	5,2 kg
805 mm	9,7 kg
FRAZ. / SECT.	

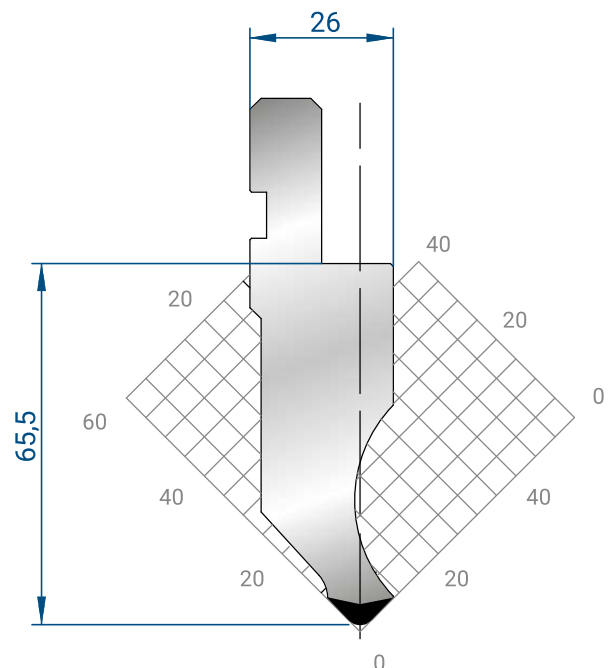

### 1012

Mat = C45  
 H = 65.50  
 Max T/m = 100  
 $\alpha = 88^\circ$   
 R = 3

835 mm	10,4 kg
415 mm	5,2 kg
805 mm	9,6 kg
FRAZ. / SECT.	

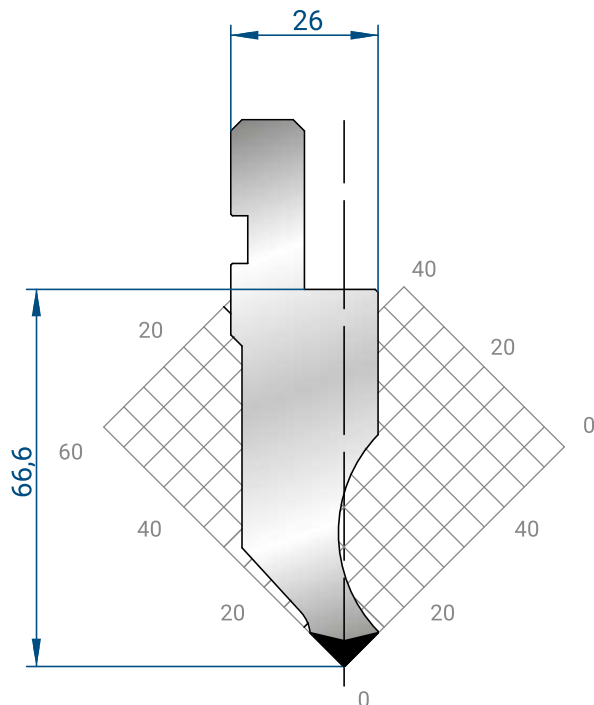

### 1065

Mat = C45  
 H = 66.60  
 Max T/m = 100  
 $\alpha = 88^\circ$   
 R = 0.25

835 mm	10,5 kg
415 mm	5,2 kg
805 mm	9,7 kg
FRAZ. / SECT.	

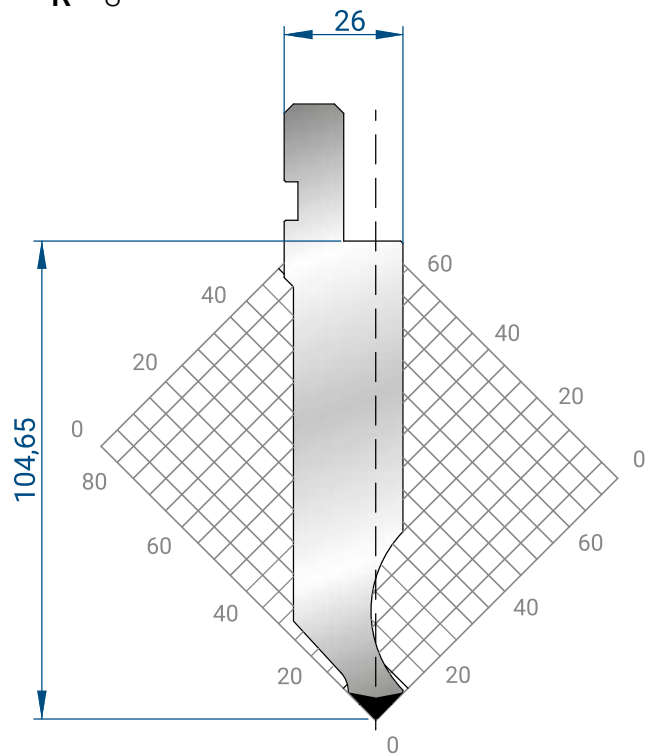

### 1063

Mat = C45  
 H = 104.65  
 Max T/m = 100  
 $\alpha = 88^\circ$   
 R = 0.8

835 mm	16,4 kg
415 mm	8,2 kg
805 mm	15,1 kg
FRAZ. / SECT.	

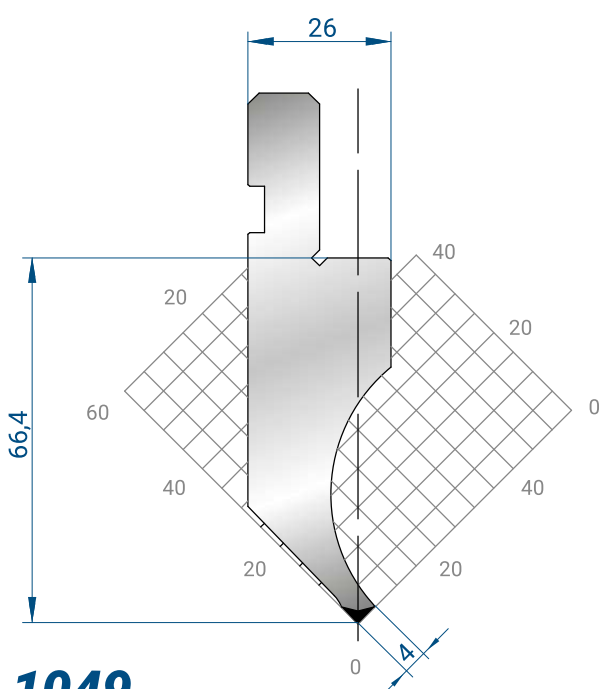

### 1049

**Mat** = C45  
 bonificato / *tempered*  
**H** = 66.40  
**Max T/m** = 35  
 $\alpha$  = 88°  
**R** = 0.6

835 mm	9,9 kg
415 mm	4,9 kg
805 mm	9,1 kg
FRAZ. / SECT.	

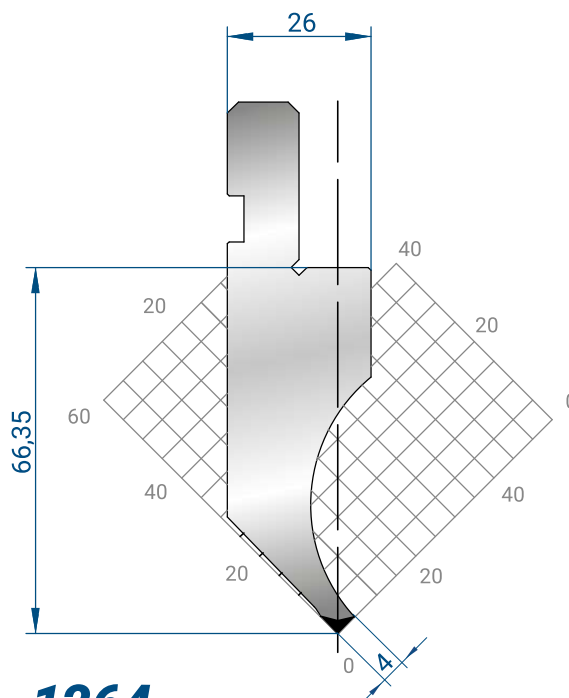

### 1264

**Mat** = C45  
 bonificato / *tempered*  
**H** = 66.35  
**Max T/m** = 35  
 $\alpha$  = 88°  
**R** = 0.25

835 mm	9,9 kg
415 mm	4,9 kg
805 mm	9,1 kg
FRAZ. / SECT.	

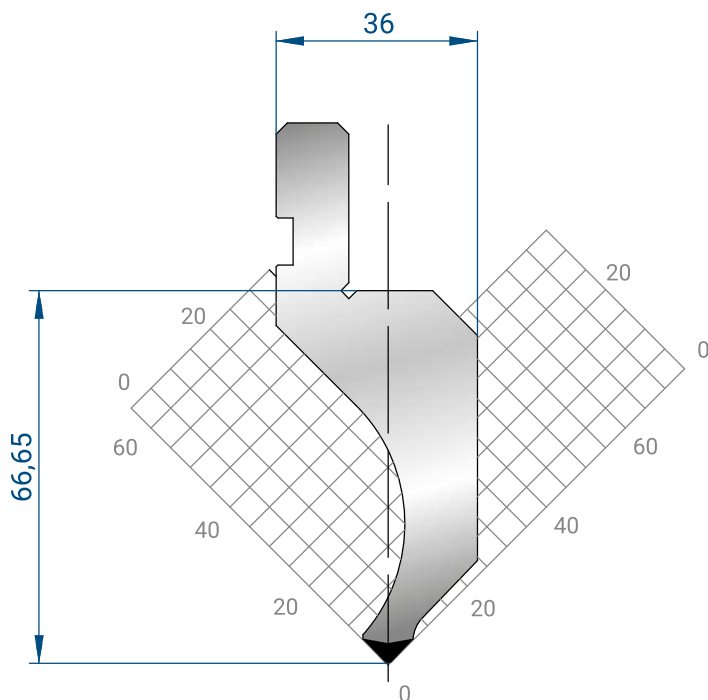

### 1081

**Mat** = C45  
**H** = 66.65  
**Max T/m** = 60  
 $\alpha$  = 88°  
**R** = 0.8

835 mm	10,1 kg
415 mm	5,0 kg
805 mm	9,3 kg
FRAZ. / SECT.	

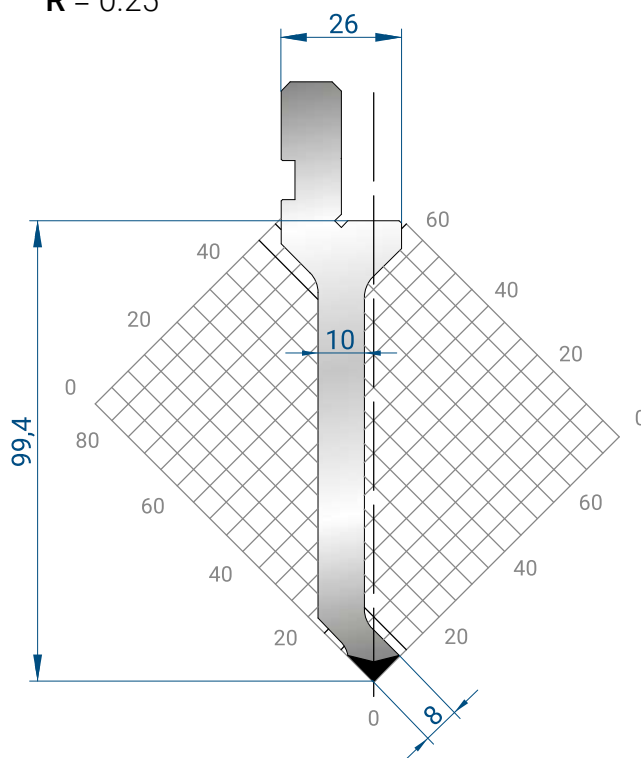

### 1029

**Mat** = C45  
**H** = 99.40  
**Max T/m** = 50  
 $\alpha$  = 88°  
**R** = 0.6

835 mm	9,7 kg
415 mm	4,8 kg
805 mm	8,9 kg
FRAZ. / SECT.	

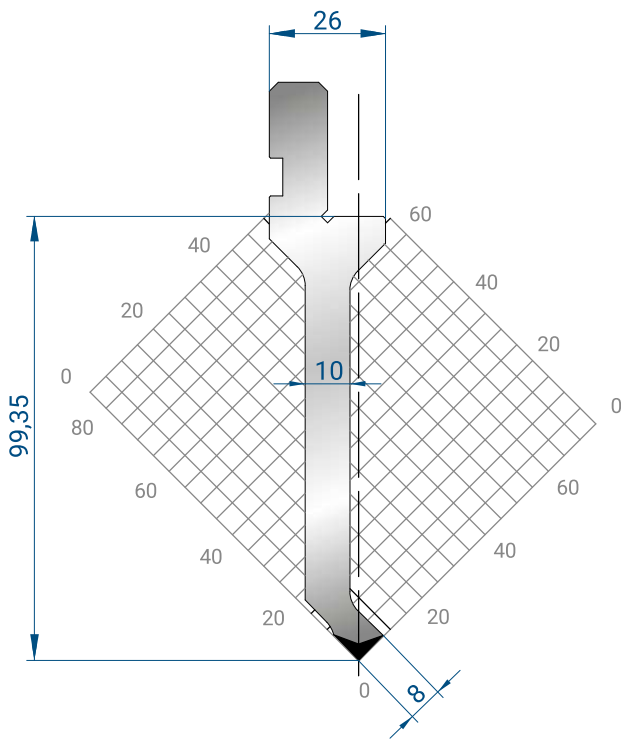

### 1262

Mat = C45  
 H = 99.35  
 Max T/m = 50  
 $\alpha = 88^\circ$   
 R = 0.25

835 mm	9,7 kg
415 mm	4,8 kg
805 mm	8,9 kg
FRAZ. / SECT.	

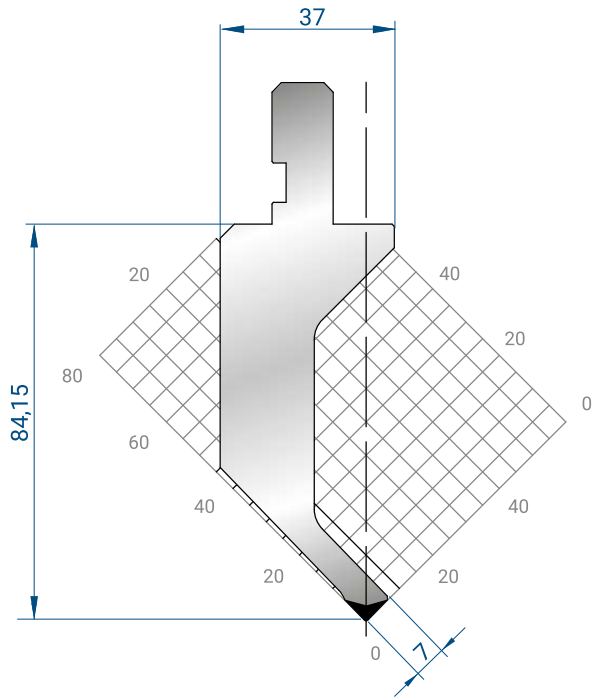

### 1020

Mat = 42CrMo4  
 bonificato / tempered  
 H = 84.15  
 Max T/m = 20  
 $\alpha = 88^\circ$   
 R = 0.6

835 mm	12,8 kg
415 mm	6,4 kg
805 mm	11,8 kg
FRAZ. / SECT.	

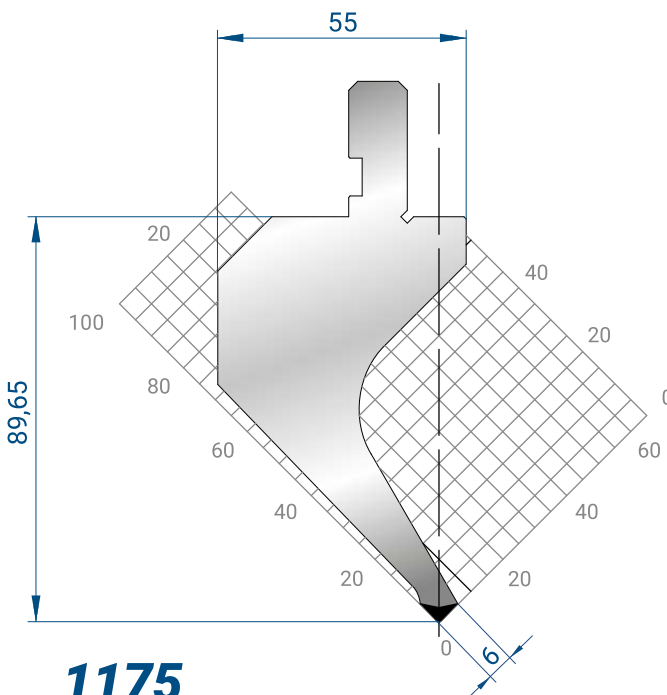

### 1175

Mat = C45  
 bonificato / tempered  
 H = 89.65  
 Max T/m = 50  
 $\alpha = 88^\circ$   
 R = 0.8

835 mm	18,4 kg
415 mm	9,1 kg
805 mm	16,9 kg
FRAZ. / SECT.	

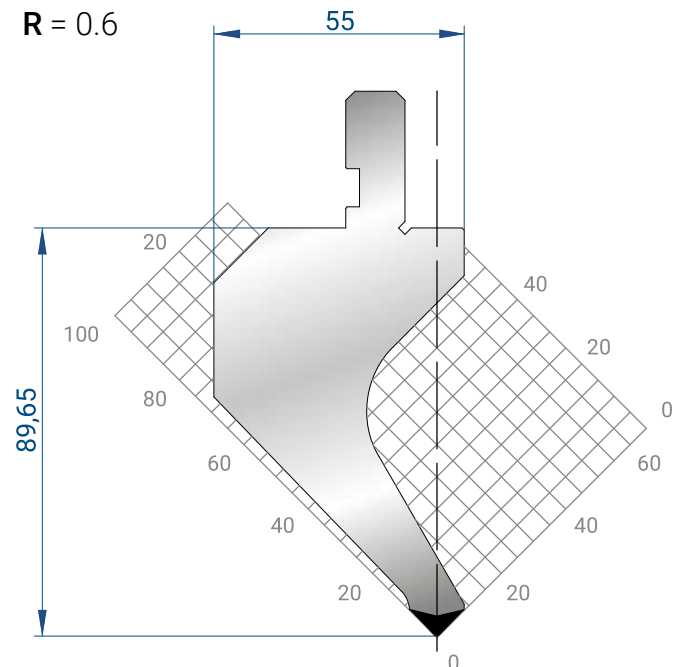

### 1014

Mat = C45  
 H = 89.65  
 Max T/m = 60  
 $\alpha = 88^\circ$   
 R = 0.8

835 mm	19,5 kg
415 mm	9,7 kg
805 mm	17,9 kg
FRAZ. / SECT.	

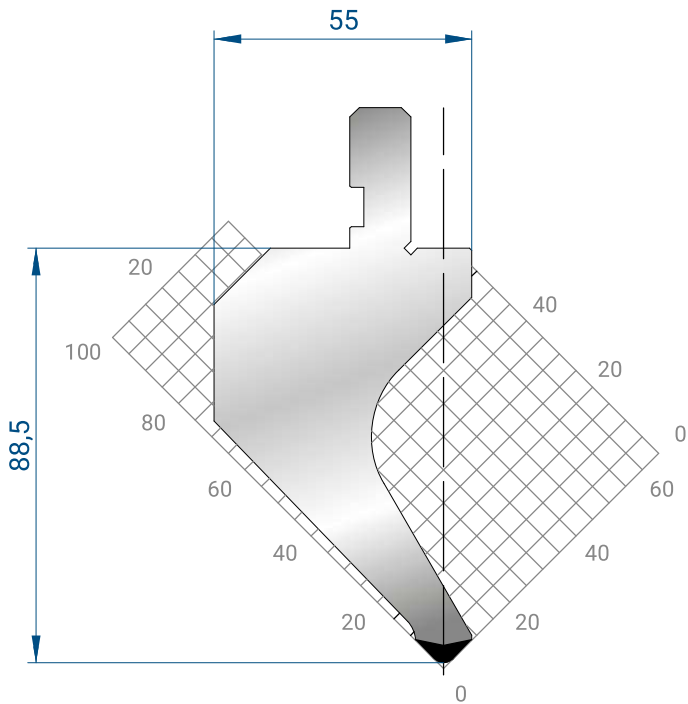

### 1015

Mat = C45  
 H = 88.50  
 Max T/m = 60  
 $\alpha = 88^\circ$   
 R = 3

835 mm	19,4 kg
415 mm	9,6 kg
805 mm	17,8 kg
FRAZ. / SECT.	

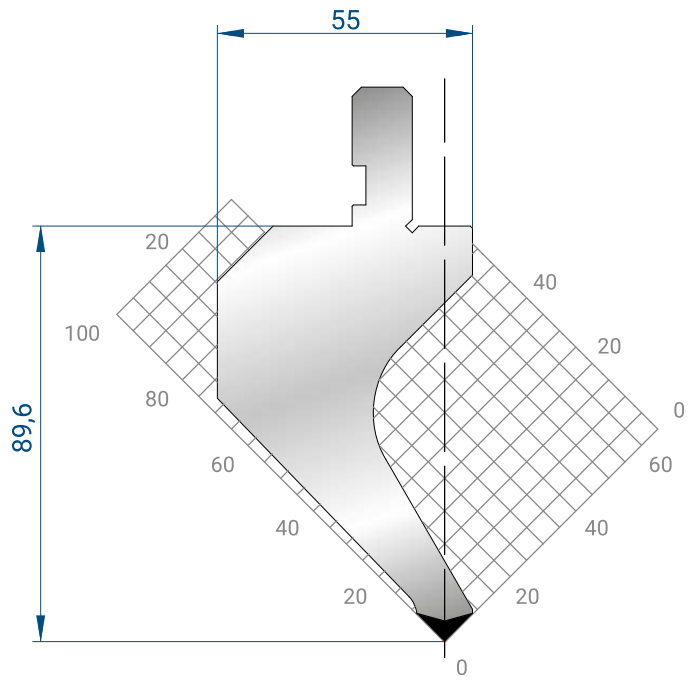

### 1266

Mat = C45  
 H = 89.60  
 Max T/m = 60  
 $\alpha = 88^\circ$   
 R = 0.25

835 mm	19,4 kg
415 mm	9,7 kg
805 mm	17,9 kg
FRAZ. / SECT.	

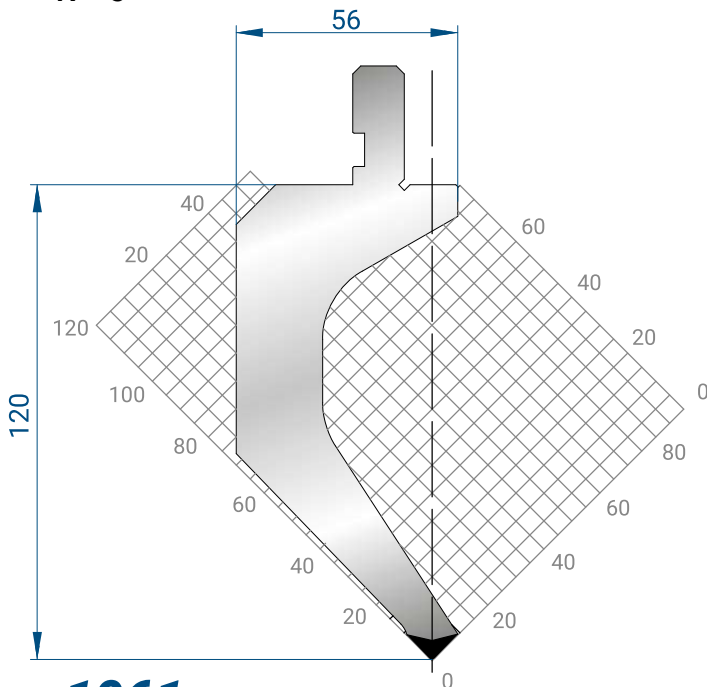

### 1061

Mat = C45  
 bonificato / tempered  
 H = 120  
 Max T/m = 50  
 $\alpha = 88^\circ$   
 R = 0.8

835 mm	22,0 kg
415 mm	10,9 kg
805 mm	20,2 kg
FRAZ. / SECT.	

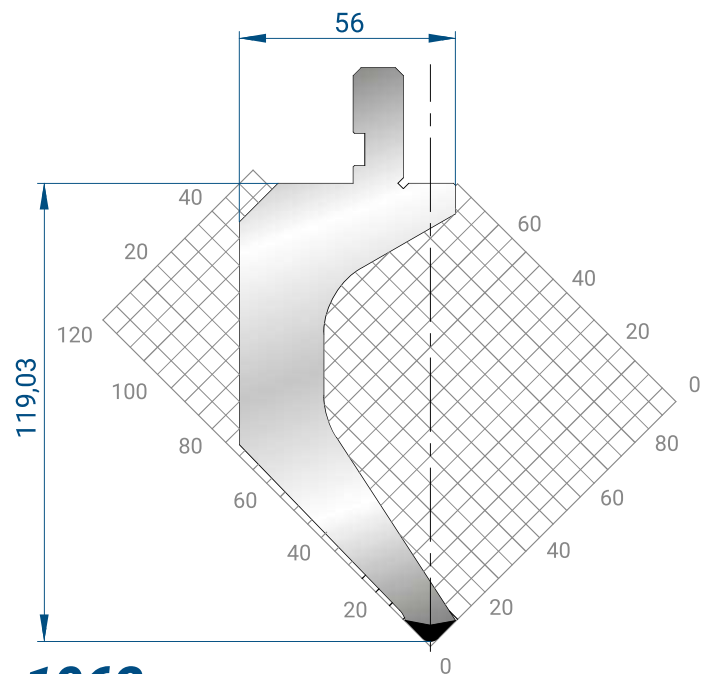

### 1062

Mat = C45  
 bonificato / tempered  
 H = 119.03  
 Max T/m = 50  
 $\alpha = 88^\circ$   
 R = 3

835 mm	22,0 kg
415 mm	10,9 kg
805 mm	20,2 kg
FRAZ. / SECT.	

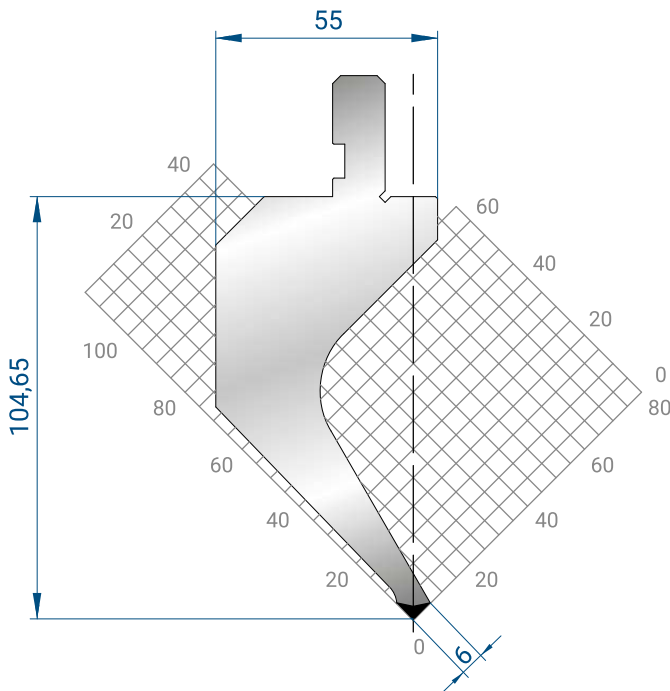

### 1173

Mat = C45  
 bonificato / tempered  
 H = 104.65  
 Max T/m = 50  
 $\alpha = 88^\circ$   
 R = 0.8

835 mm	20,7 kg
415 mm	10,3 kg
805 mm	19,0 kg
FRAZ. / SECT.	

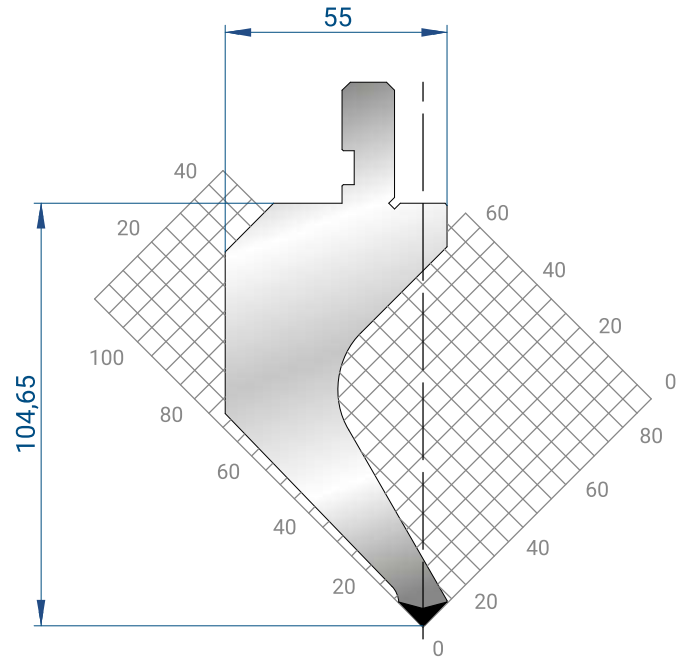

### 1017

Mat = C45  
 H = 104.65  
 Max T/m = 50  
 $\alpha = 88^\circ$   
 R = 0.8

835 mm	21,9 kg
415 mm	10,9 kg
805 mm	21,1 kg
FRAZ. / SECT.	

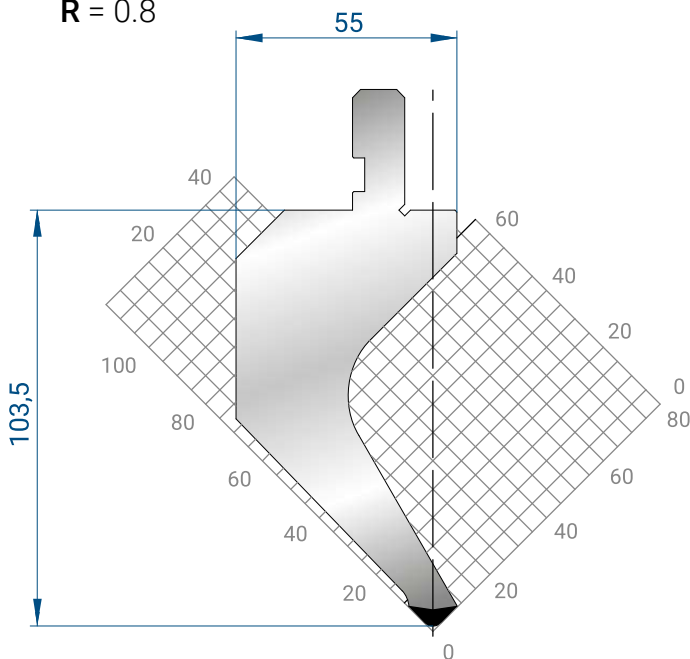

### 1018

Mat = C45  
 H = 103.50  
 Max T/m = 50  
 $\alpha = 88^\circ$   
 R = 3

835 mm	21,8 kg
415 mm	10,8 kg
805 mm	20,0 kg
FRAZ. / SECT.	

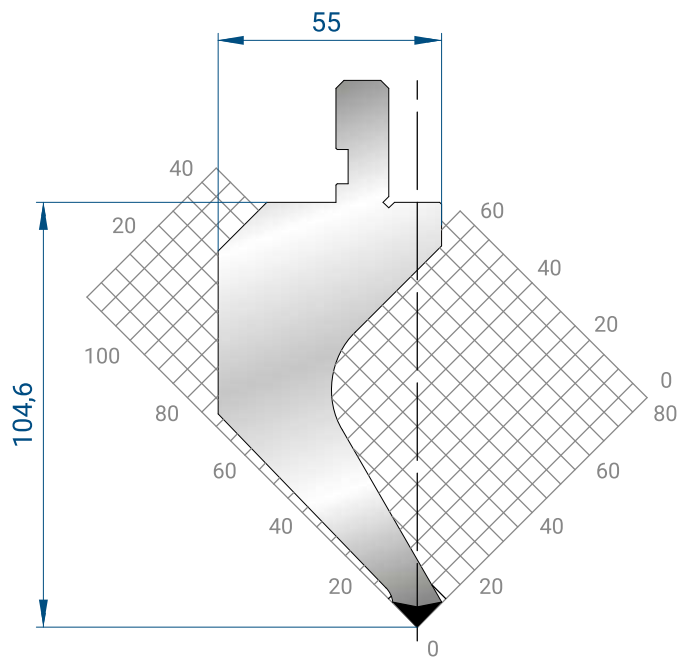

### 1268

Mat = C45  
 H = 104.60  
 Max T/m = 50  
 $\alpha = 88^\circ$   
 R = 0.25

835 mm	21,8 kg
415 mm	10,8 kg
805 mm	20,0 kg
FRAZ. / SECT.	

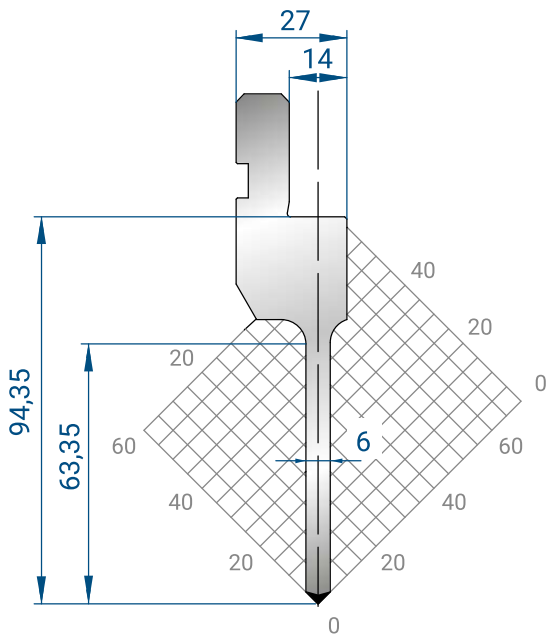

### 1270

**Mat** = C45  
 bonificato/ *tempered*  
**H** = 94.35  
**Max T/m** = 50  
 $\alpha$  = 88°  
**R** = 0.25

835 mm	9,4 kg
415 mm	4,7 kg
805 mm	8,6 kg
FRAZ. / SECT.	

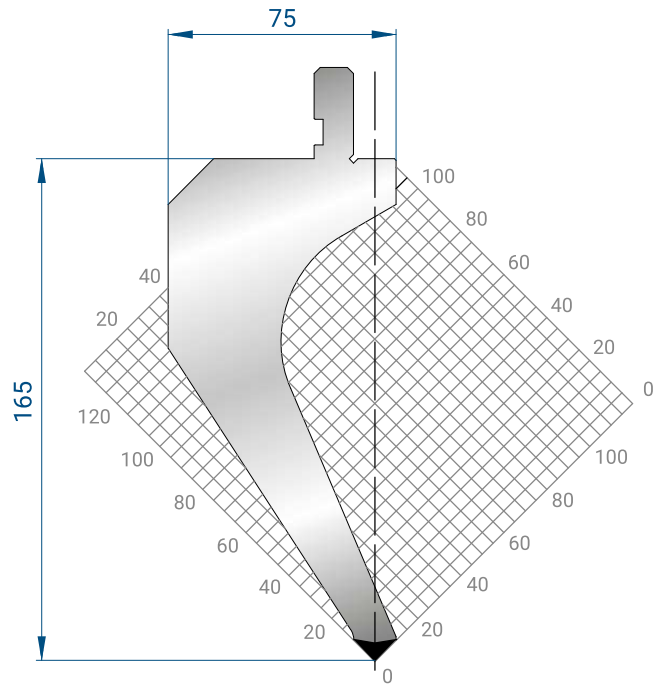

### 1031

**Mat** = C45  
**H** = 165  
**Max T/m** = 60  
 $\alpha$  = 88°  
**R** = 0.8

835 mm	39,2 kg
415 mm	19,5 kg
805 mm	36,0 kg
FRAZ. / SECT.	

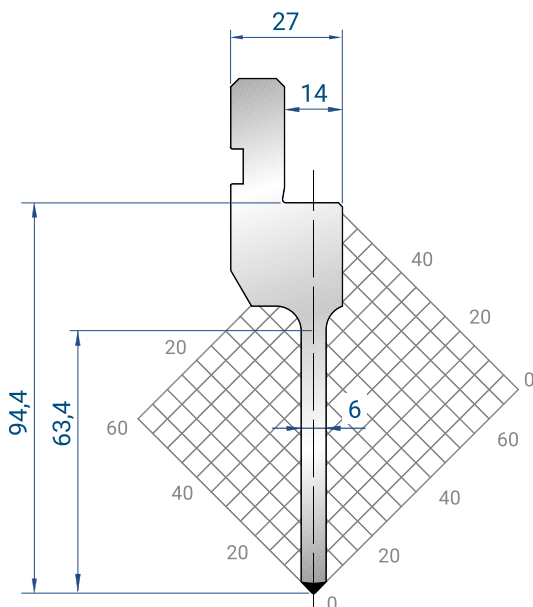

### 1084

**Mat** = C45  
 bonificato / *tempered*  
**H** = 94.40  
**Max T/m** = 50  
 $\alpha$  = 88°  
**R** = 0.6

835 mm	9,4 kg
415 mm	4,7 kg
805 mm	8,6 kg
FRAZ. / SECT.	

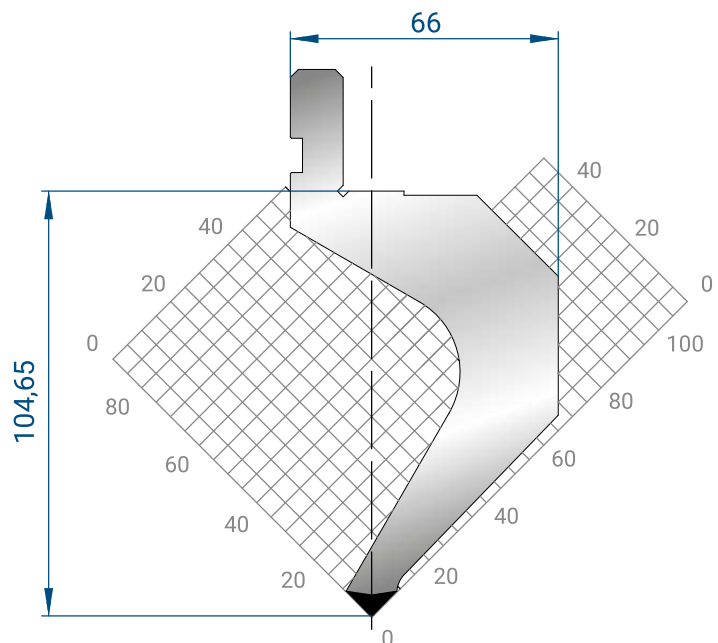

### 1082

**Mat** = C45  
**H** = 104.65  
**Max T/m** = 45  
 $\alpha$  = 88°  
**R** = 0.8

835 mm	21,1 kg
415 mm	10,5 kg
805 mm	19,4 kg
FRAZ. / SECT.	

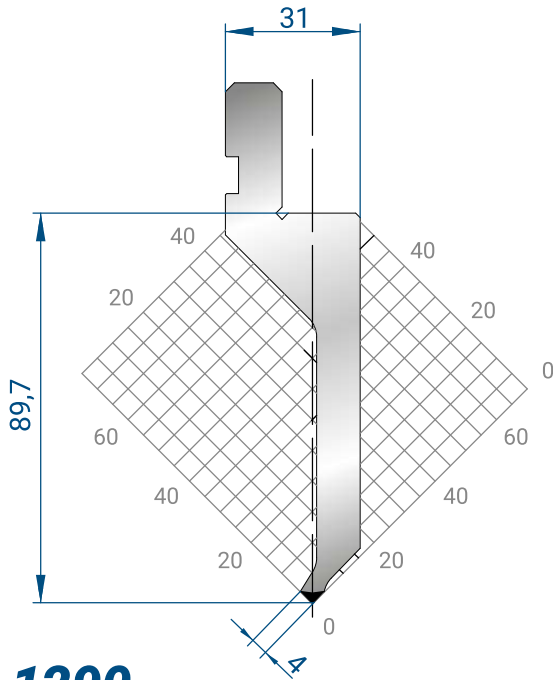

### 1290

Mat = C45  
 bonificato / *tempered*  
 H = 89.70  
 Max T/m = 30  
 $\alpha = 88^\circ$   
 R = 0.6

835 mm	10,0 kg
415 mm	5,0 kg
805 mm	9,3 kg
FRAZ. / SECT.	

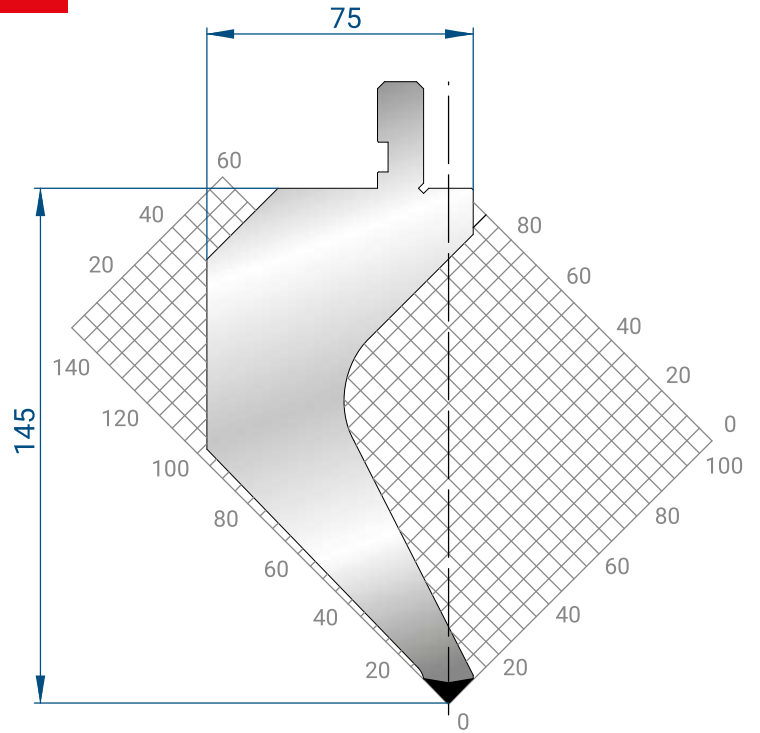

### 1030

Mat = C45  
 H = 145  
 Max T/m = 80  
 $\alpha = 88^\circ$   
 R = 0.8

835 mm	39,3 kg
415 mm	19,5 kg
805 mm	36,1 kg
FRAZ. / SECT.	

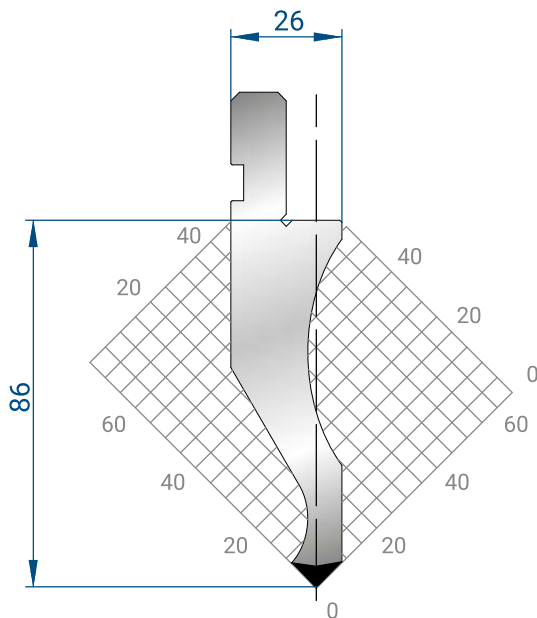

### 1022

Mat = C45  
 H = 86  
 Max T/m = 100  
 $\alpha = 88^\circ$   
 R = 0.8

835 mm	10,9 kg
415 mm	5,4 kg
805 mm	10,0 kg
FRAZ. / SECT.	

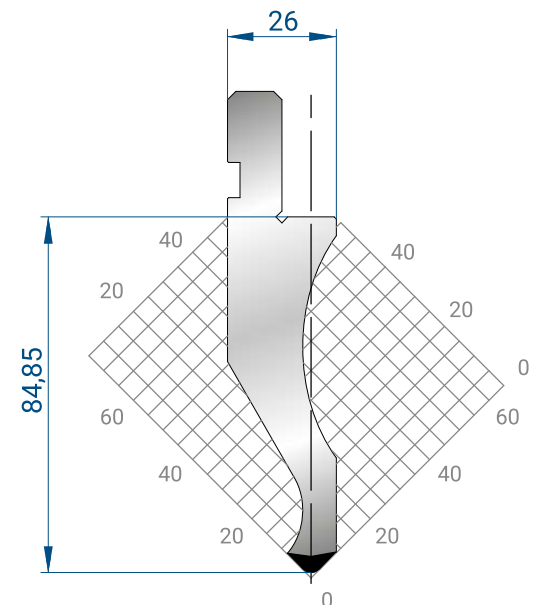

### 1023

Mat = C45  
 H = 84.85  
 Max T/m = 100  
 $\alpha = 88^\circ$   
 R = 3

835 mm	10,9 kg
415 mm	5,4 kg
805 mm	10,0 kg
FRAZ. / SECT.	

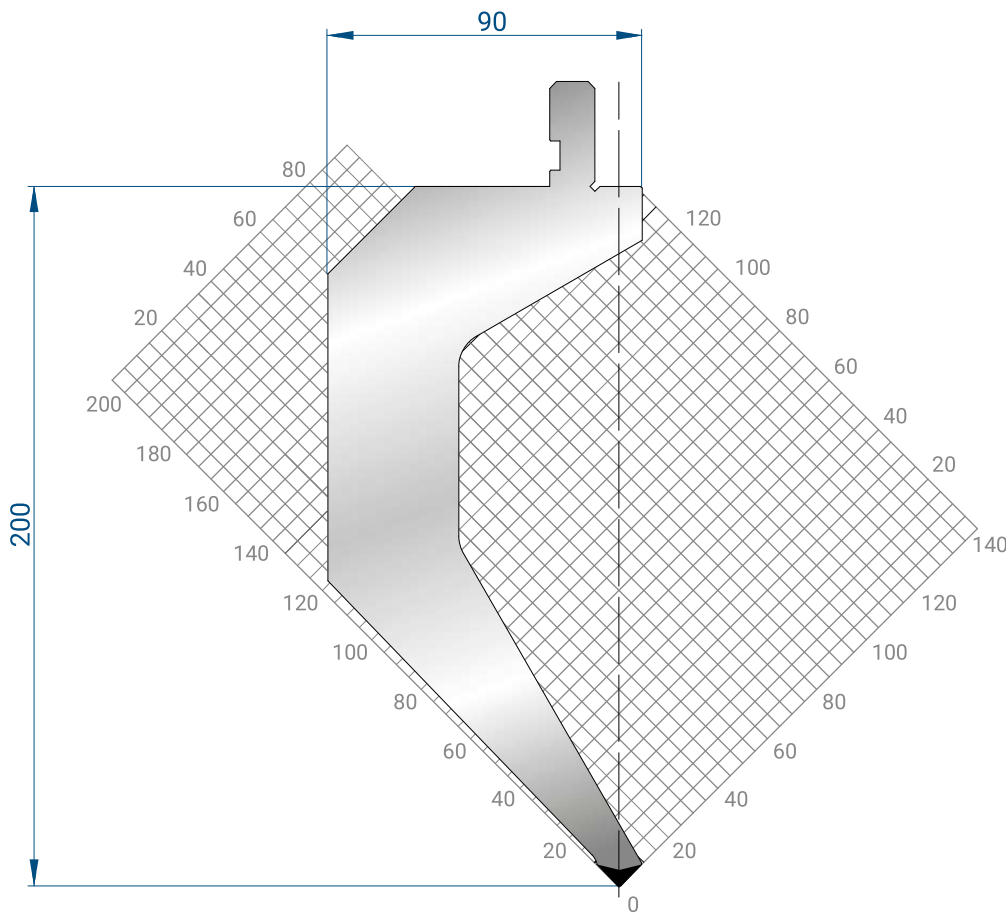

## 1291

**Mat** = C45  
 bonificato / *tempered*  
**H** = 200  
**Max T/m** = 85  
 $\alpha$  = 88°  
**R** = 0.8

505 mm	32,4 kg
805 mm	49,2 kg
FRAZ. / SECT.	

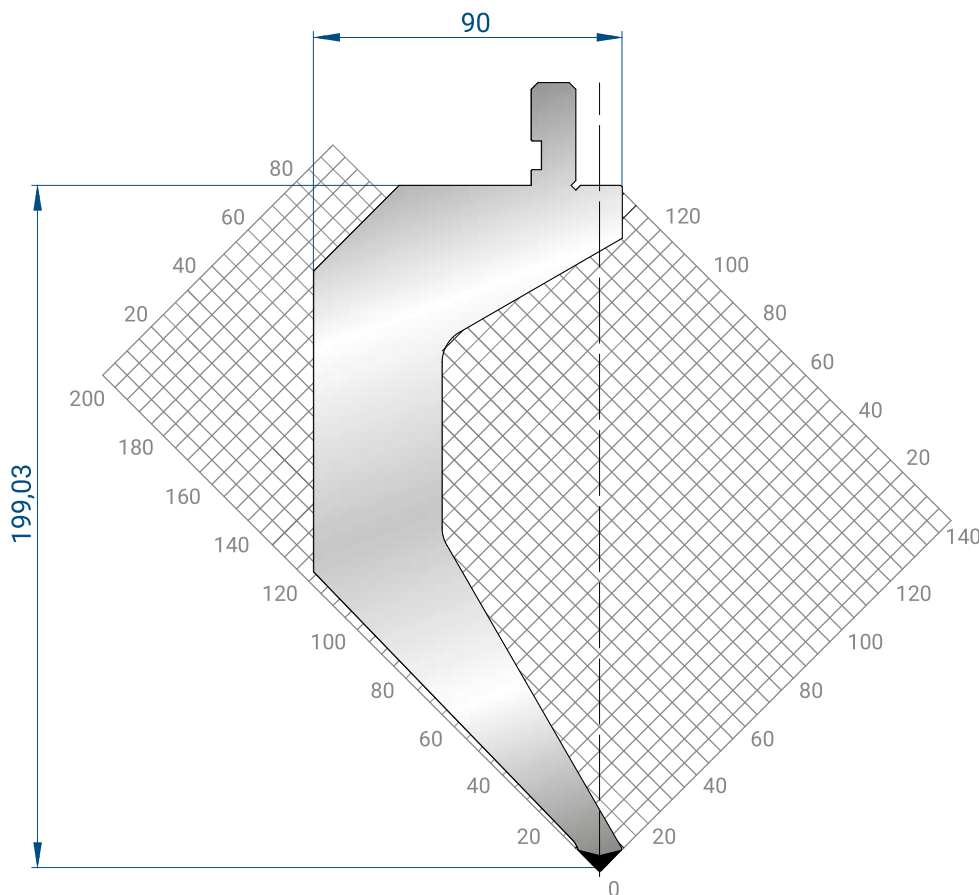

## 1301

**Mat** = C45  
 bonificato / *tempered*  
**H** = 199.03  
**Max T/m** = 85  
 $\alpha$  = 88°  
**R** = 3

505 mm	32,4 kg
805 mm	49,2 kg
FRAZ. / SECT.	

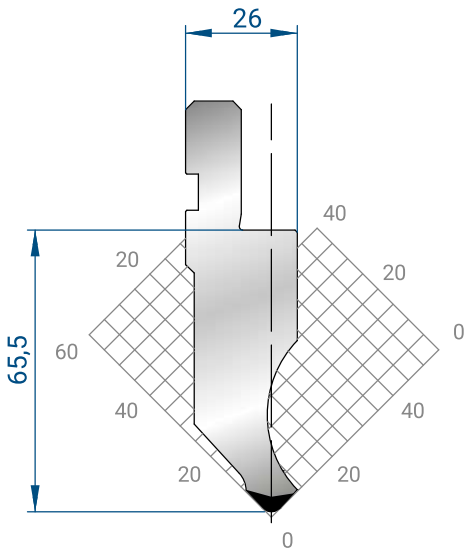

### 1177

Mat = C45  
 H = 65.50  
 Max T/m = 100  
 $\alpha = 85^\circ$   
 R = 3

835 mm	10,4 kg
415 mm	5,2 kg
805 mm FRAZ. / SECT.	9,6 kg

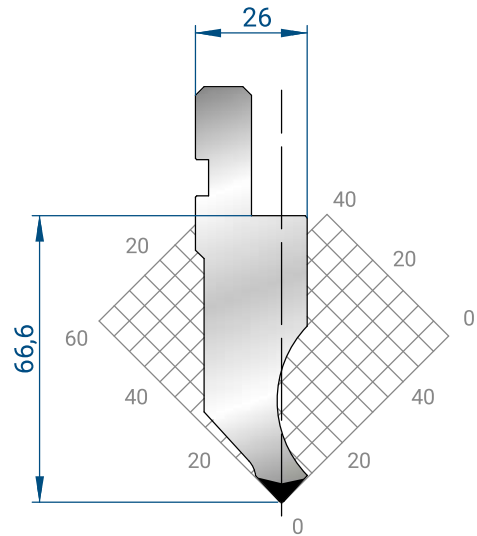

### 1260

Mat = C45  
 H = 66.60  
 Max T/m = 100  
 $\alpha = 85^\circ$   
 R = 0.8

835 mm	10,4 kg
415 mm	5,2 kg
805 mm FRAZ. / SECT.	9,6 kg

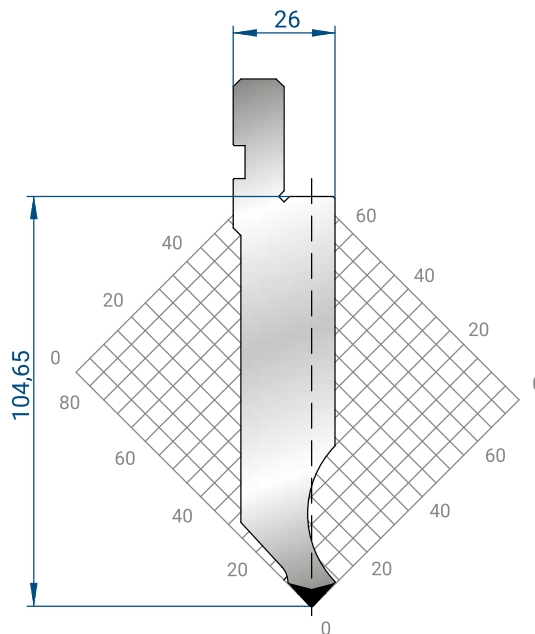

### 1281

Mat = C45  
 H = 104.65  
 Max T/m = 100  
 $\alpha = 85^\circ$   
 R = 0.8

835 mm	16,4 kg
415 mm	8,2 kg
805 mm FRAZ. / SECT.	15,1 kg

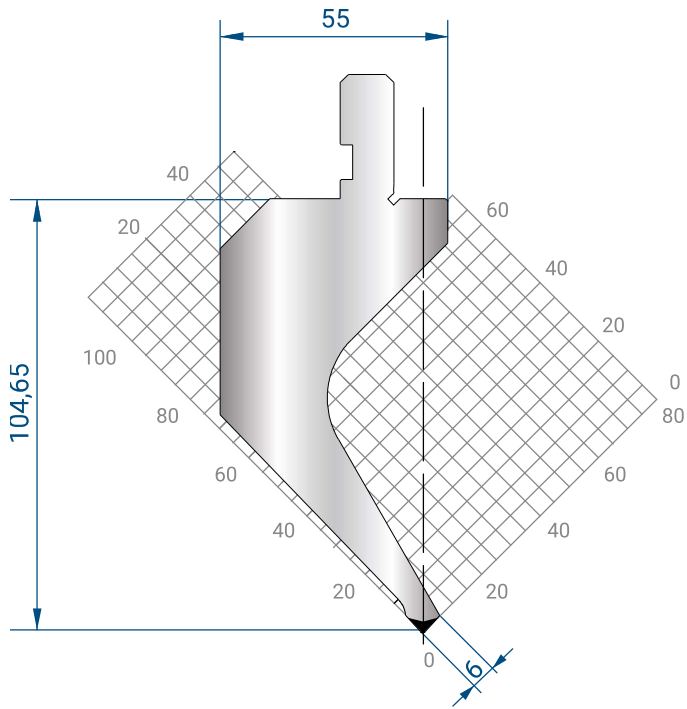

### 1171

Mat = C45  
 H = 104.65  
 Max T/m = 50  
 $\alpha = 85^\circ$   
 R = 0.8

835 mm	20,7 kg
415 mm	10,3 kg
805 mm	19,0 kg
FRAZ. / SECT.	

### 1172

Mat = C45  
 H = 104.60  
 Max T/m = 50  
 $\alpha = 85^\circ$   
 R = 0.8

835 mm	21,4 kg
415 mm	10,7 kg
805 mm	19,7 kg
FRAZ. / SECT.	

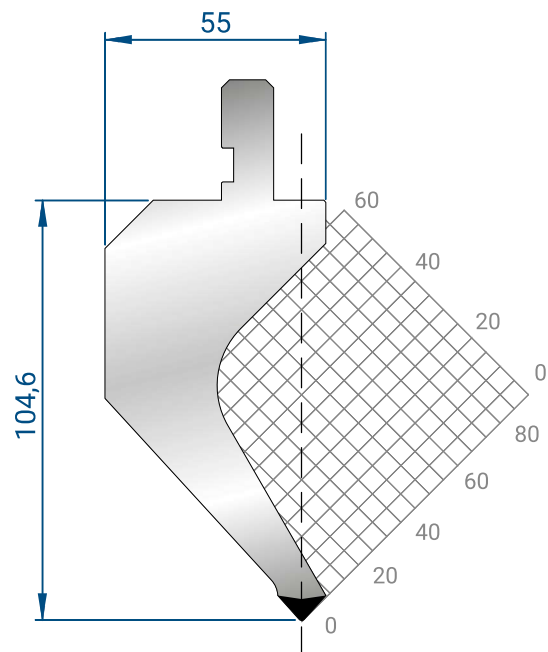

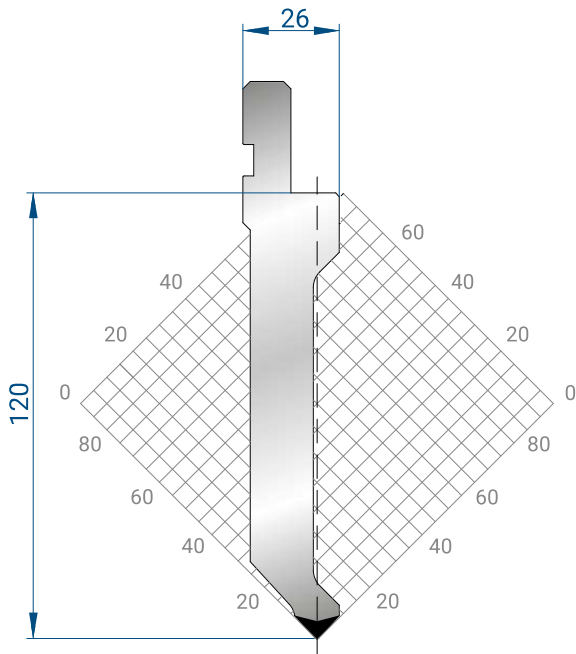

### 1309

**Mat** = C45  
**H** = 120.00  
**Max T/m** = 70  
 $\alpha$  = 85°  
**R** = 0.8

835 mm	15,9 kg
415 mm	7,9 kg
805 mm	14,7 kg
FRAZ. / SECT.	

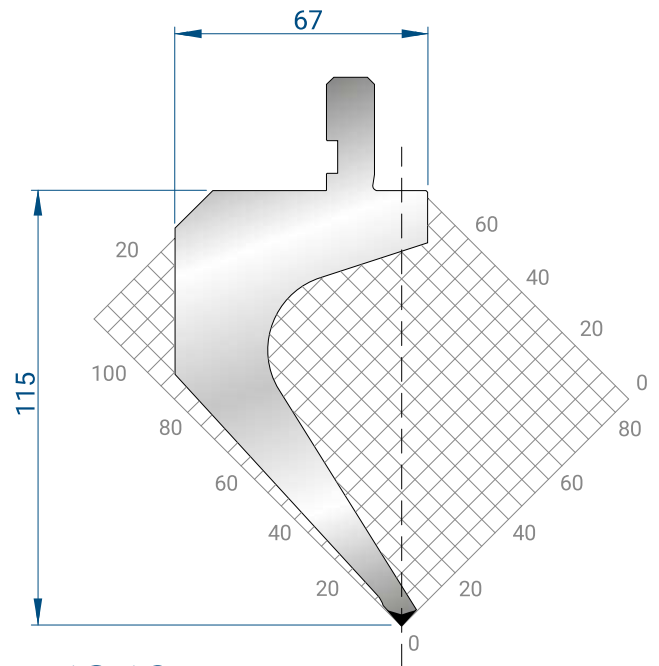

### 1310

**Mat** = 42CrMo4  
 bonificato / *tempered*  
**H** = 115.00  
**Max T/m** = 35  
 $\alpha$  = 85°  
**R** = 0.8

835 mm	22,7 kg
415 mm	11,3 kg
805 mm	20,8 kg
FRAZ. / SECT.	

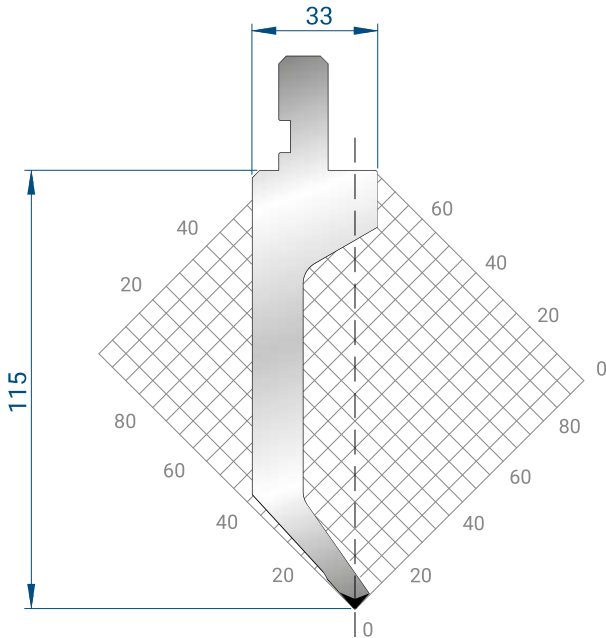

### 1312

**Mat** = 42CrMo4  
 bonificato / *tempered*  
**H** = 115.00  
**Max T/m** = 20  
 $\alpha$  = 85°  
**R** = 0.6

835 mm	14,3 kg
415 mm	7,1 kg
805 mm	13,1 kg
FRAZ. / SECT.	

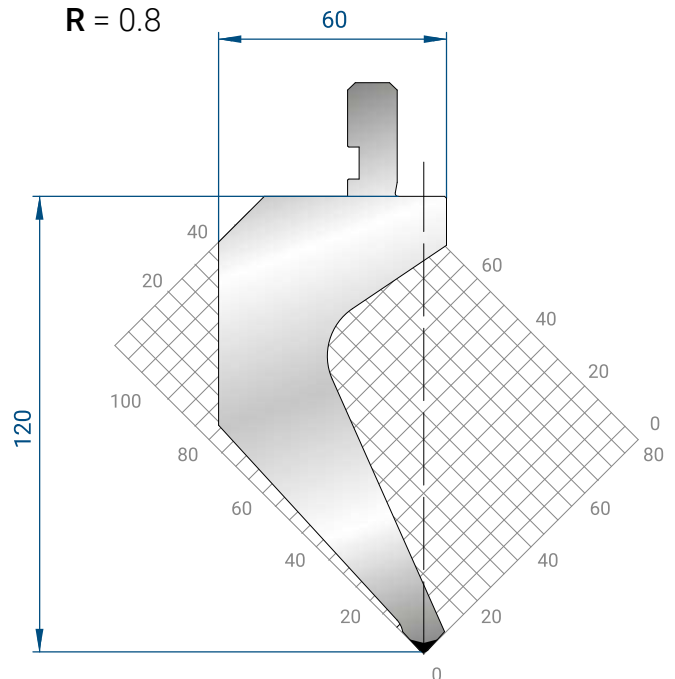

### 1322

**Mat** = 42CrMo4  
 bonificato / *tempered*  
**H** = 120.00  
**Max T/m** = 100  
 $\alpha$  = 85°  
**R** = 1.5

835 mm	26,6 kg
415 mm	13,2 kg
805 mm	24,5 kg
FRAZ. / SECT.	

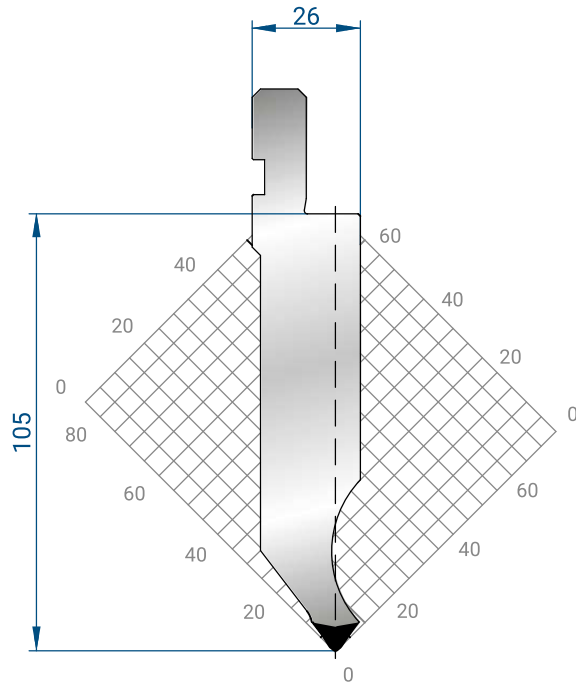

**1338**

**Mat** = 42CrMo4  
 bonificato/ tempered  
**H** = 105  
**Max T/m** = 100  
 $\alpha$  = 75°  
**R** = 0.8

835 mm	16,4 kg
415 mm	8,1 kg
805 mm	15,0 kg
FRAZ. / SECT.	

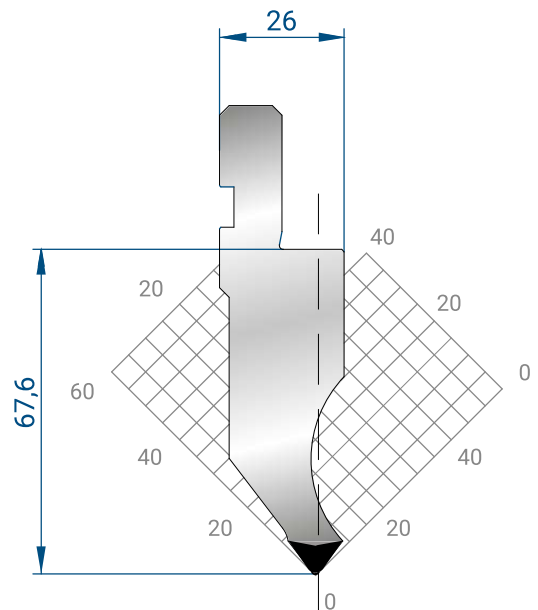

**1339**

**Mat** = 42CrMo4  
 bonificato/ tempered  
**H** = 67,6  
**Max T/m** = 100  
 $\alpha$  = 75°  
**R** = 0.8

835 mm	10,5 kg
415 mm	5,2 kg
805 mm	9,7 kg
FRAZ. / SECT.	

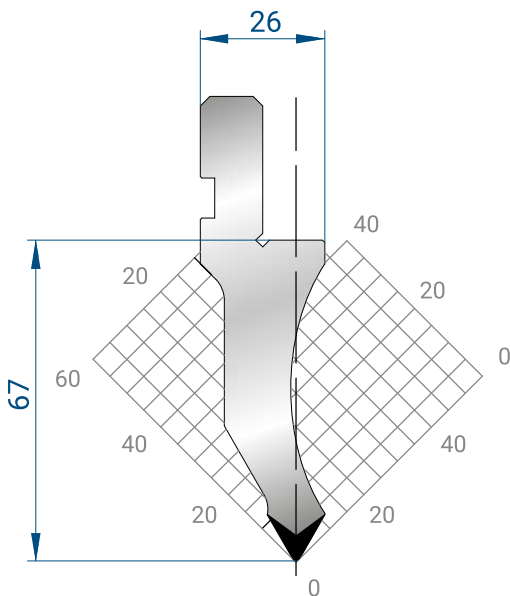

**1026**

**Mat** = C45  
**H** = 67.00  
**Max T/m** = 80  
 $\alpha$  = 60°  
**R** = 0.8

835 mm	8,6 kg
415 mm	4,3 kg
805 mm	7,9 kg
FRAZ. / SECT.	

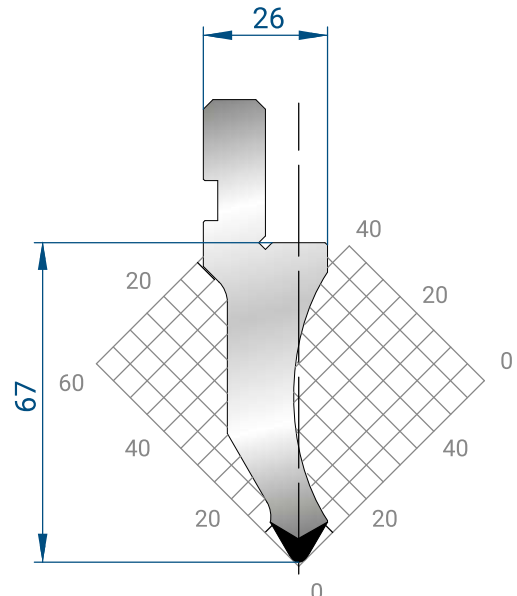

**1027**

**Mat** = C45  
**H** = 67.00  
**Max T/m** = 80  
 $\alpha$  = 60°  
**R** = 2

835 mm	8,8 kg
415 mm	4,4 kg
805 mm	8,1 kg
FRAZ. / SECT.	

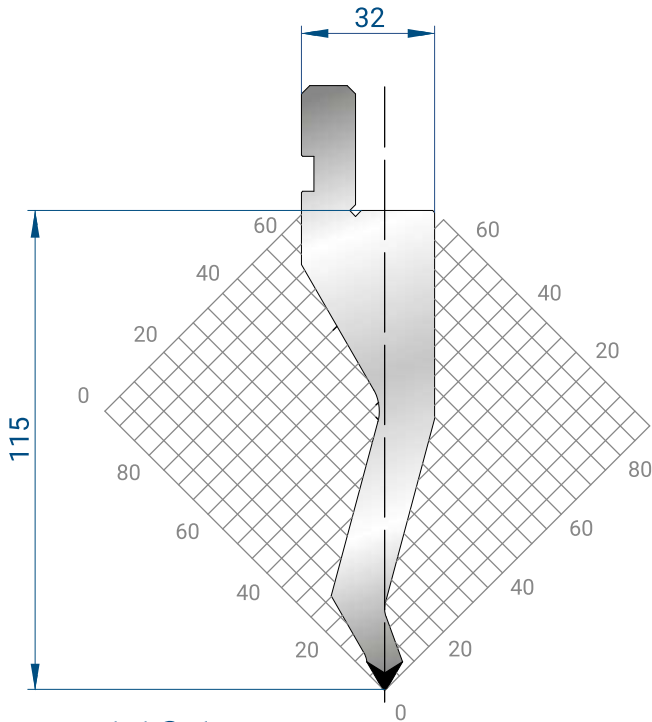

### 1191

**Mat** = C45  
**H** = 115.00  
**Max T/m** = 60  
 $\alpha = 60^\circ$   
**R** = 0.8

835 mm	15,2 kg
415 mm	7,6 kg
805 mm FRAZ. / SECT.	14,0 kg

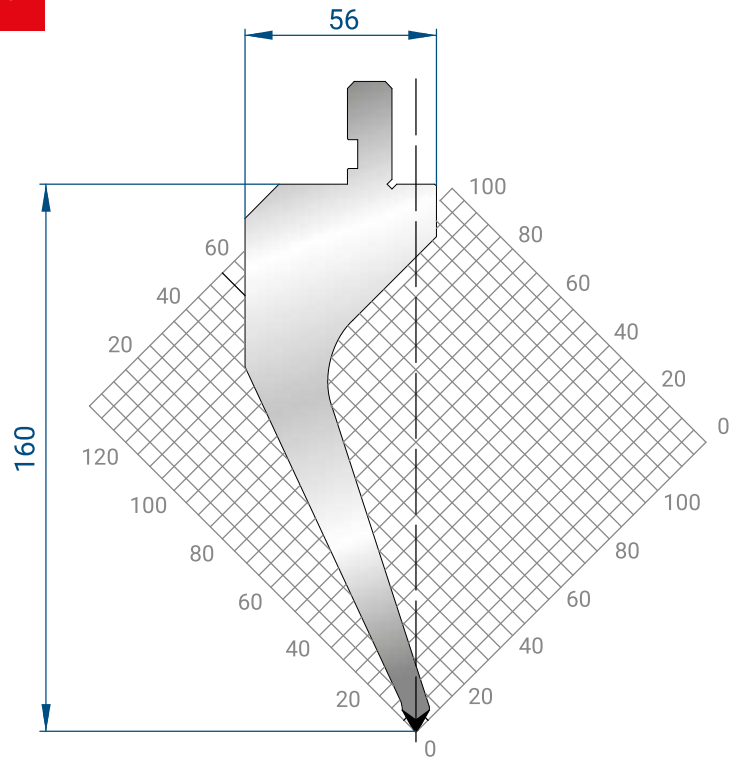

### 1190

**Mat** = C45  
 bonificato / tempered  
**H** = 160.00  
**Max T/m** = 40  
 $\alpha = 60^\circ$   
**R** = 0.8

835 mm	26,9 kg
415 mm	13,4 kg
805 mm FRAZ. / SECT.	24,7 kg

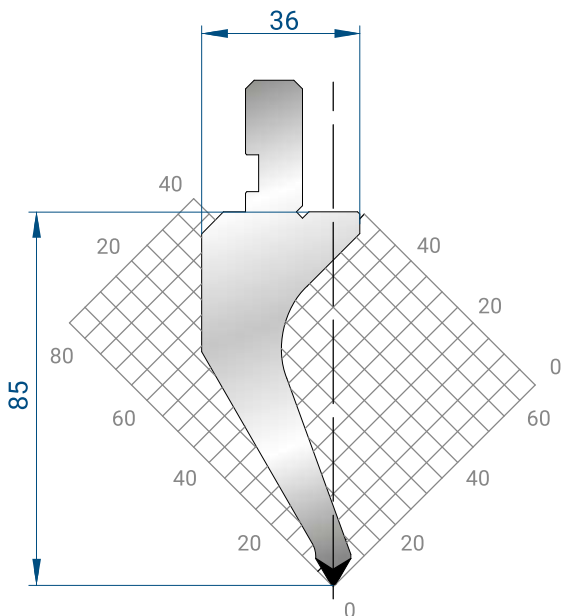

### 1162

**Mat** = 42CrMo4  
 bonificato / tempered  
**H** = 85.00  
**Max T/m** = 40  
 $\alpha = 60^\circ$   
**R** = 0.8

835 mm	11,7 kg
415 mm	5,8 kg
805 mm FRAZ. / SECT.	10,7 kg

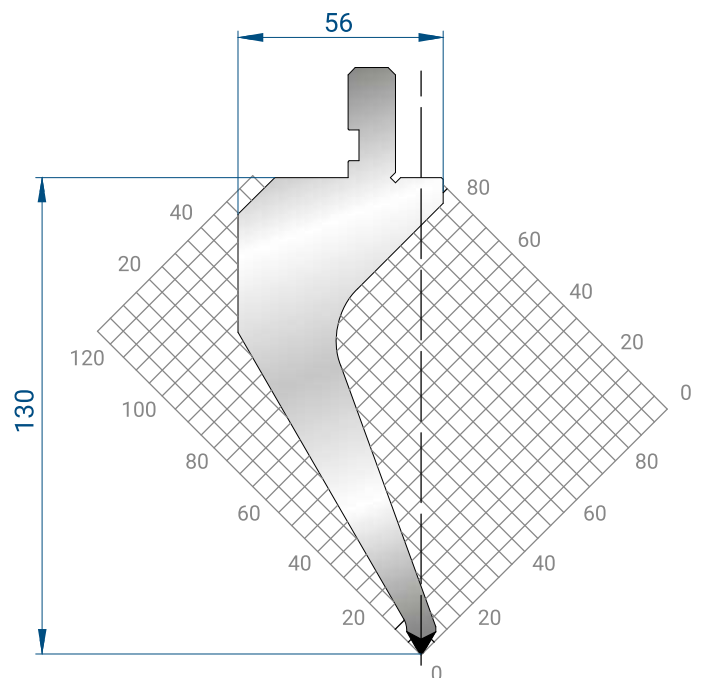

### 1163

**Mat** = C45  
 bonificato / tempered  
**H** = 130.00  
**Max T/m** = 40  
 $\alpha = 60^\circ$   
**R** = 0.8

835 mm	22,3 kg
415 mm	11,1 kg
805 mm FRAZ. / SECT.	20,5 kg

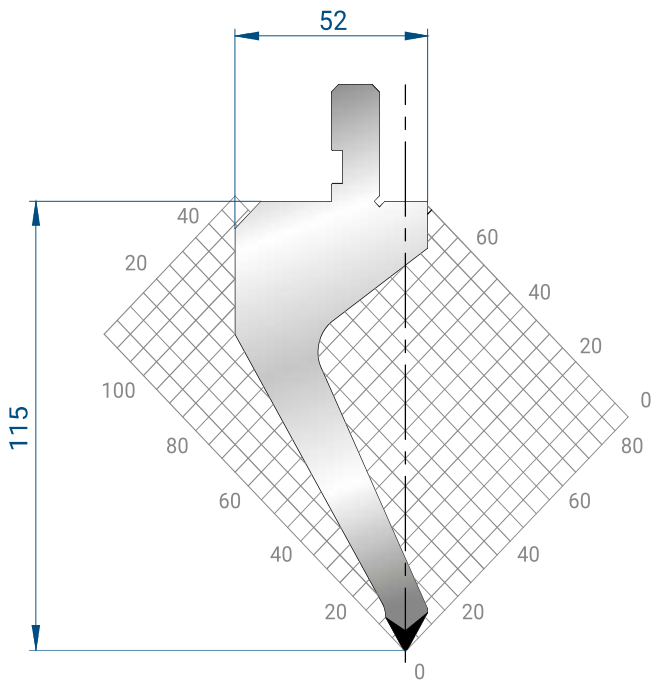

### 1272

Mat = C45  
 bonificato / tempered  
 H = 115.00  
 Max T/m = 40  
 $\alpha = 60^\circ$   
 R = 0.8

835 mm	19,2 kg
415 mm	9,6 kg
805 mm	17,7 kg
FRAZ. / SECT.	

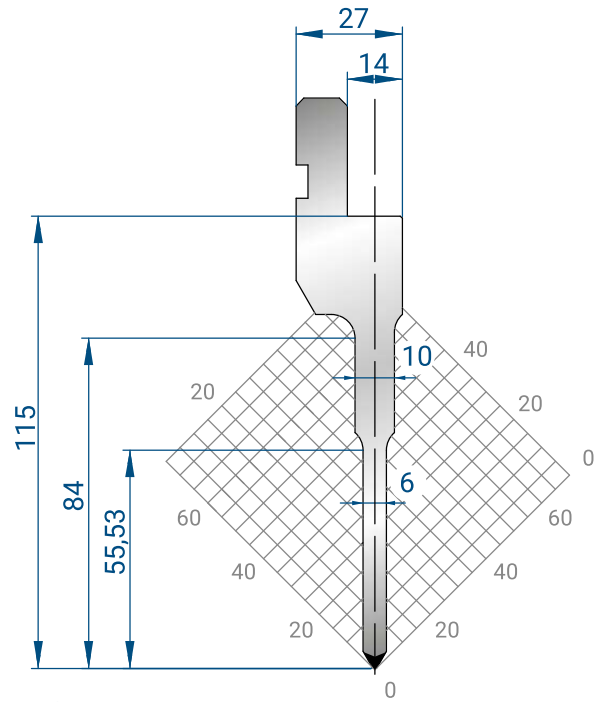

### 1271

Mat = C45  
 bonificato / tempered  
 H = 115.00  
 Max T/m = 50  
 $\alpha = 60^\circ$   
 R = 0.8

835 mm	11,0 kg
415 mm	5,5 kg
805 mm	10,1 kg
FRAZ. / SECT.	

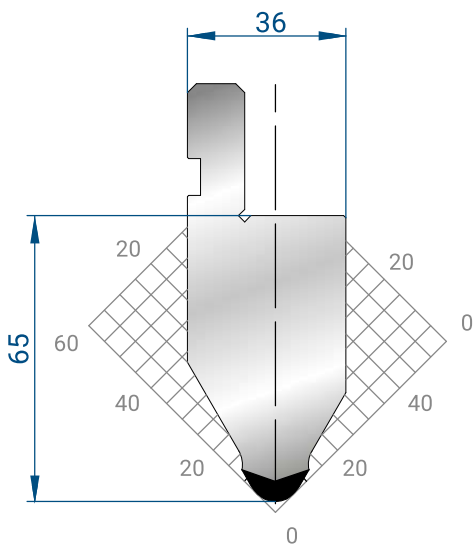

### 1032

Mat = C45  
 H = 65.00  
 Max T/m = 120  
 $\alpha = 60^\circ$   
 R = 6

835 mm	14,8 kg
415 mm	7,3 kg
805 mm	13,6 kg
FRAZ. / SECT.	

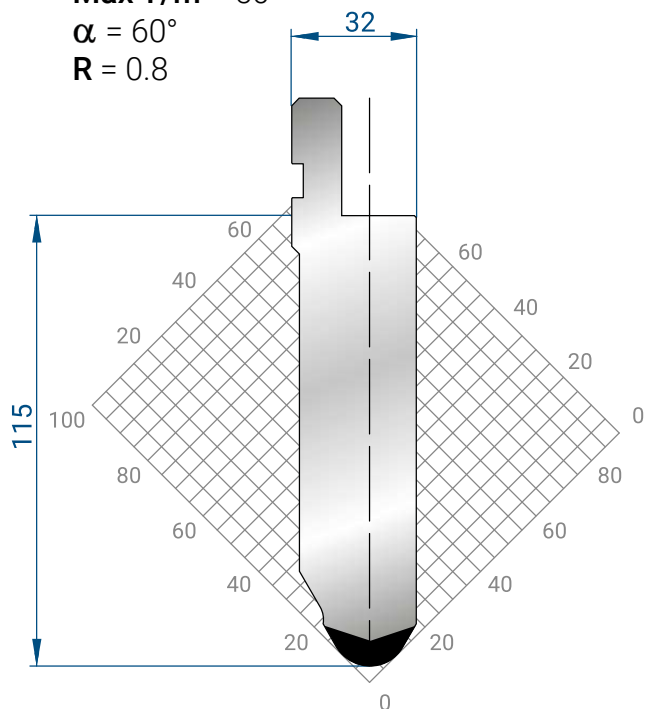

### 1283

Mat = C45  
 H = 115.00  
 Max T/m = 150  
 $\alpha = 60^\circ$   
 R = 10

835 mm	23,8 kg
415 mm	11,8 kg
805 mm	21,9 kg
FRAZ. / SECT.	

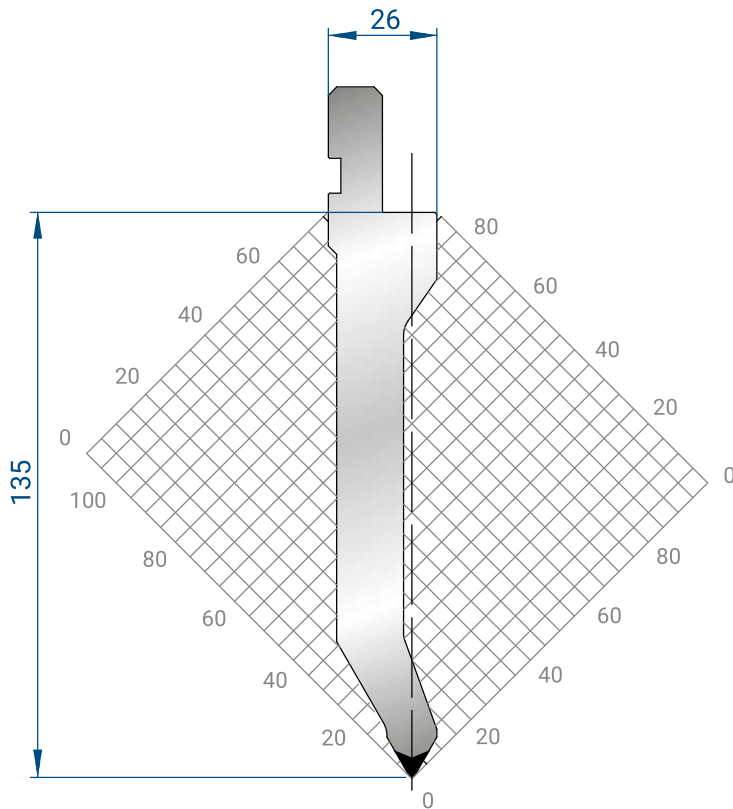

## 1284

Mat = C45  
 H = 135.00  
 Max T/m = 70  
 $\alpha = 60^\circ$   
 R = 0.8

835 mm	16,8 kg
415 mm	8,4 kg
805 mm	15,5 kg
FRAZ. / SECT.	

835 mm	40,7 kg
415 mm	20,2 kg
805 mm	37,4 kg
FRAZ. / SECT.	

## 1293

Mat = C45  
 H = 200.00  
 Max T/m = 150  
 $\alpha = 60^\circ$   
 R = 8

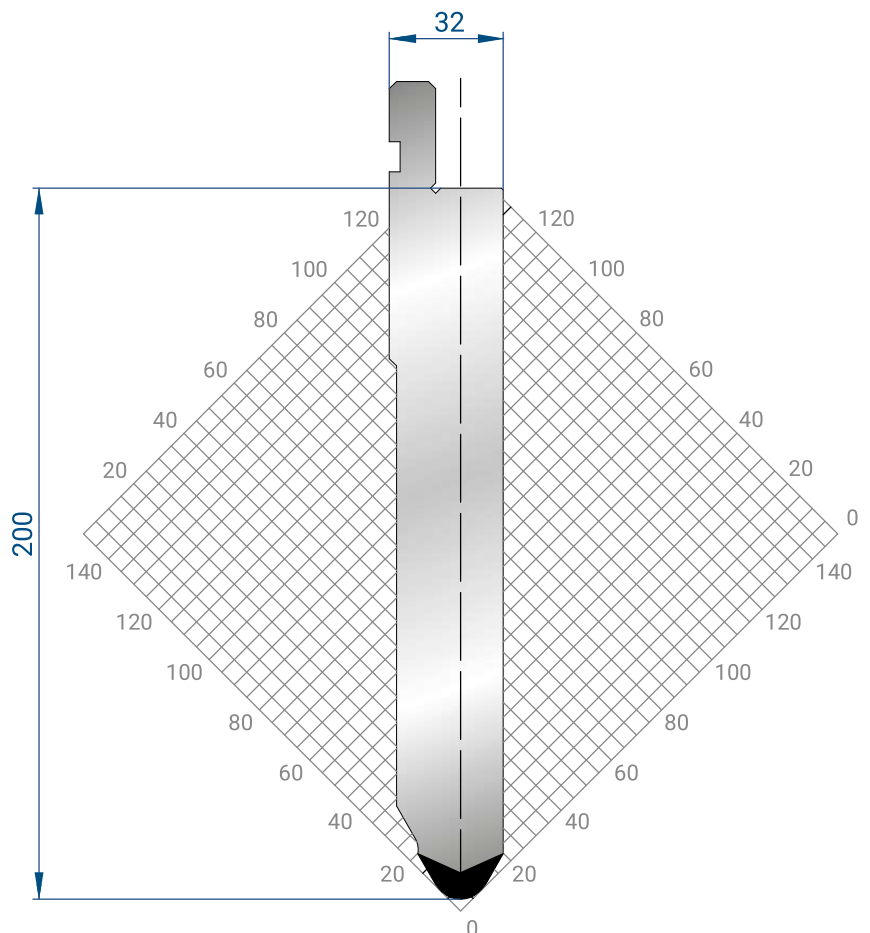

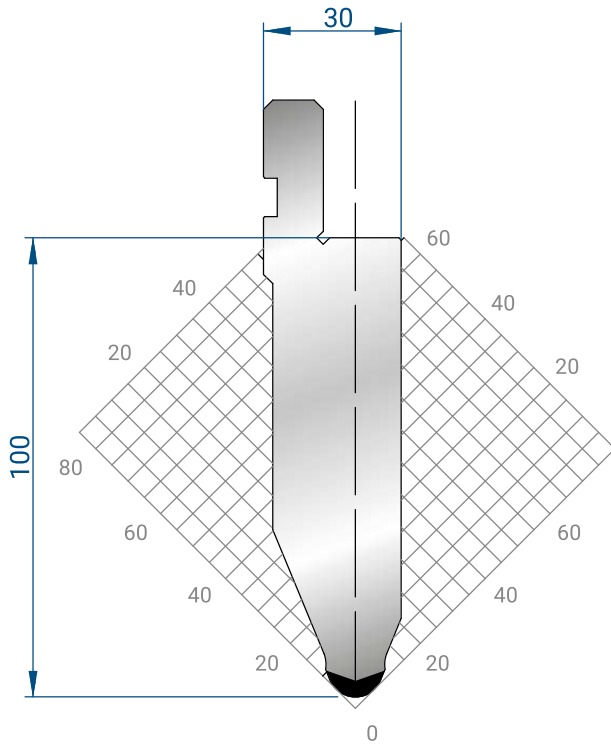

### 1053

Mat = C45  
 H = 100.00  
 Max T/m = 100  
 $\alpha = 45^\circ$   
 R = 6

835 mm	18,7 kg
415 mm	9,3 kg
805 mm	17,2 kg
FRAZ. / SECT.	

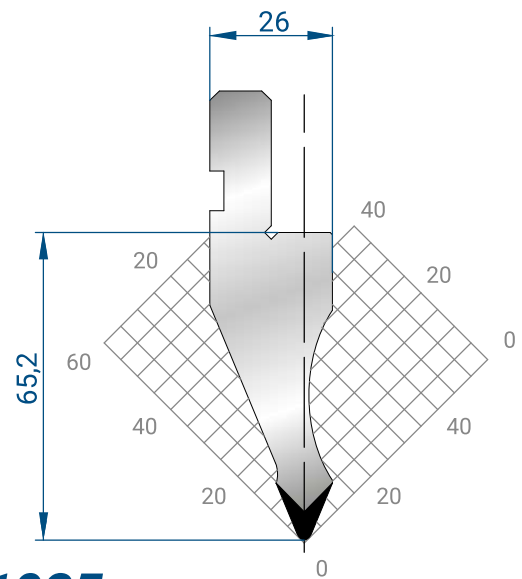

### 1025

Mat = C45  
 H = 65.20  
 Max T/m = 80  
 $\alpha = 45^\circ$   
 R = 1.5

835 mm	9,2 kg
415 mm	4,6 kg
805 mm	8,5 kg
FRAZ. / SECT.	

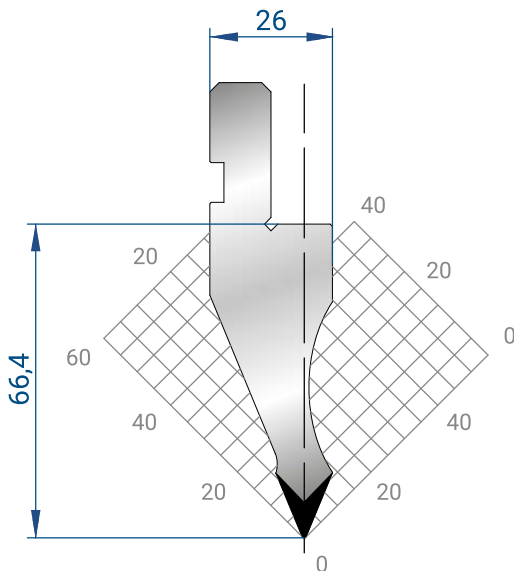

### 1024

Mat = C45  
 H = 66.40  
 Max T/m = 80  
 $\alpha = 45^\circ$   
 R = 0.5

835 mm	9,2 kg
415 mm	4,6 kg
805 mm	8,4 kg
FRAZ. / SECT.	

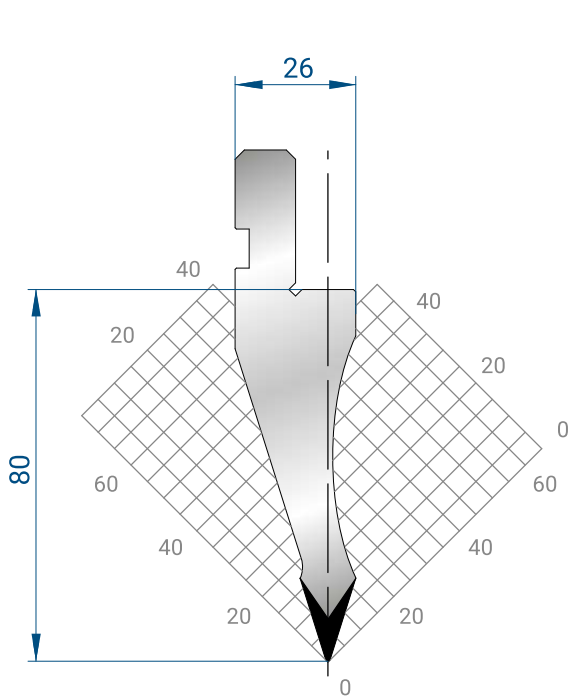

### 1035

Mat = C45  
 H = 80.00  
 Max T/m = 70  
 $\alpha = 35^\circ$   
 R = 0.5

835 mm	10,0 kg
415 mm	5,0 kg
805 mm	9,2 kg
FRAZ. / SECT.	

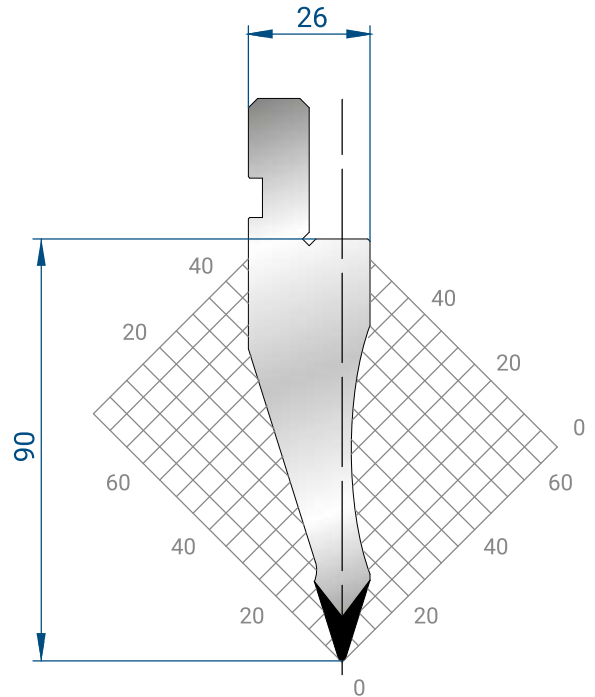

### 1047

Mat = C45  
 H = 90.00  
 Max T/m = 70  
 $\alpha = 35^\circ$   
 R = 0.8

835 mm	12,0 kg
415 mm	6,0 kg
805 mm	11,1 kg
FRAZ. / SECT.	

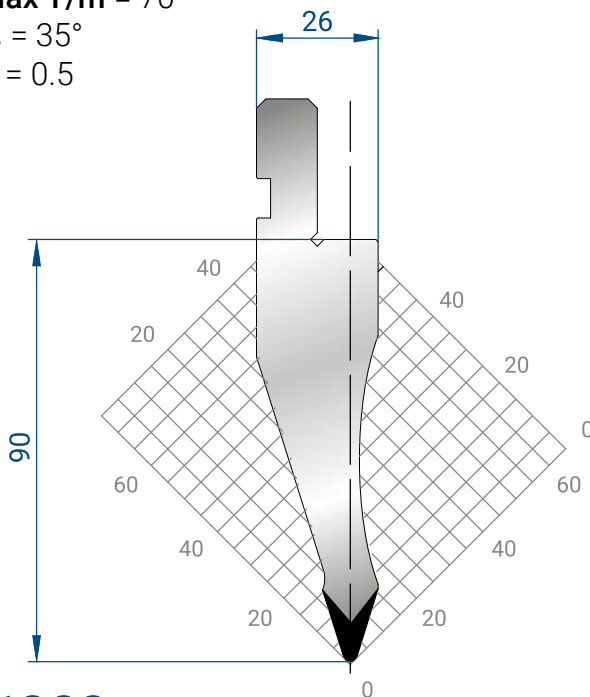

### 1282

Mat = C45  
 H = 90.00  
 Max T/m = 70  
 $\alpha = 35^\circ$   
 R = 1.5

835 mm	12,3 kg
415 mm	6,1 kg
805 mm	11,3 kg
FRAZ. / SECT.	

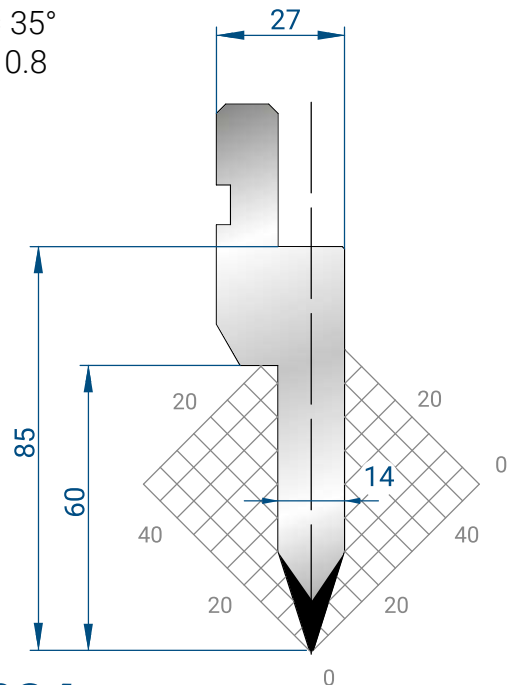

### 1034

Mat = C45  
 H = 85.00  
 Max T/m = 100  
 $\alpha = 35^\circ$   
 P = 0.8

835 mm	11,1 kg
415 mm	5,6 kg
805 mm	10,3 kg
FRAZ. / SECT.	

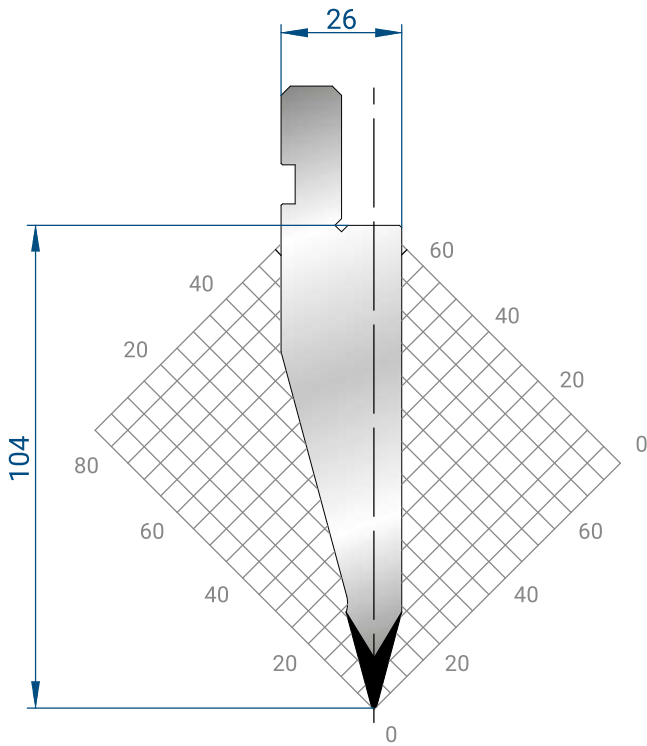

**1193**

Mat = C45  
 H = 104.00  
 Max T/m = 100  
 $\alpha = 30^\circ$   
 R = 0.6

835 mm	14,6 kg
415 mm	7,3 kg
805 mm	13,4 kg
FRAZ. / SECT.	

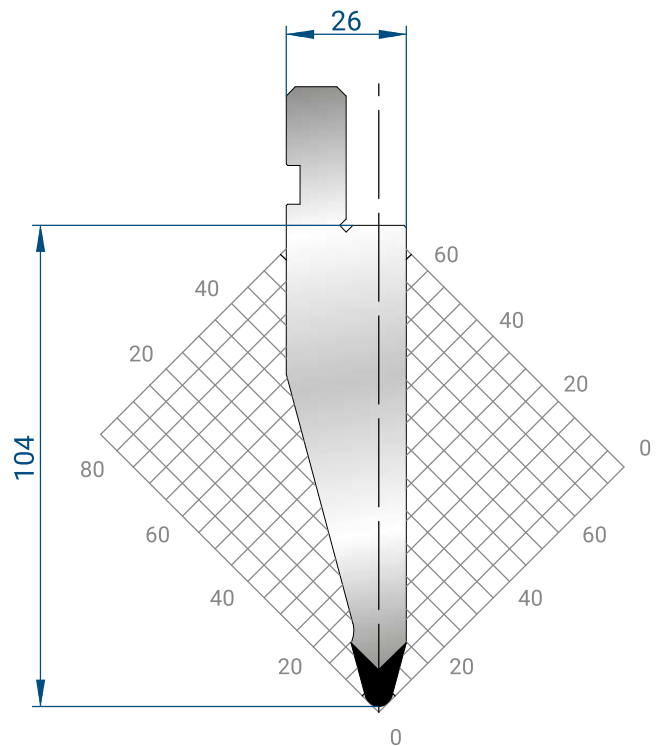

**1289**

Mat = C45  
 H = 104.00  
 Max T/m = 100  
 $\alpha = 30^\circ$   
 R = 3

835 mm	15,5 kg
415 mm	7,7 kg
805 mm	14,2 kg
FRAZ. / SECT.	

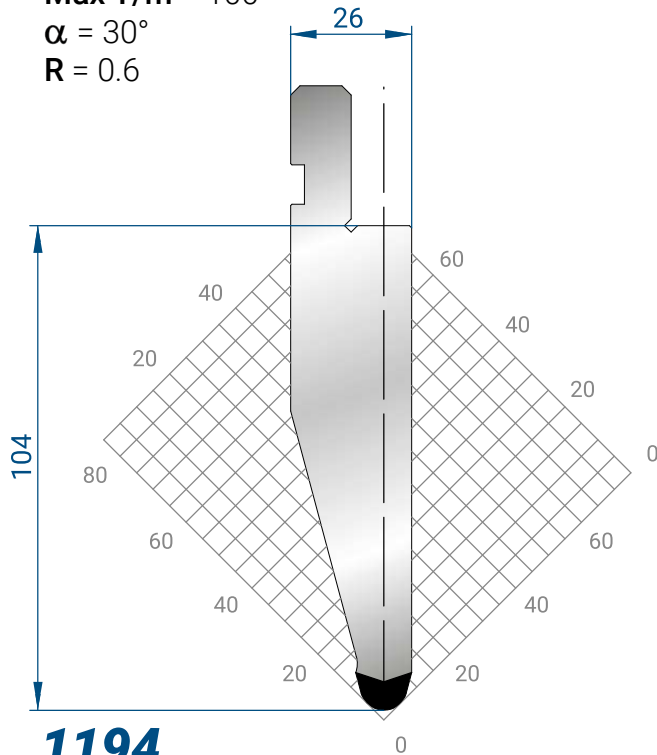

**1194**

Mat = C45  
 H = 104.00  
 Max T/m = 100  
 $\alpha = 30^\circ$   
 R = 5

835 mm	16,4 kg
415 mm	8,1 kg
805 mm	15,1 kg
FRAZ. / SECT.	

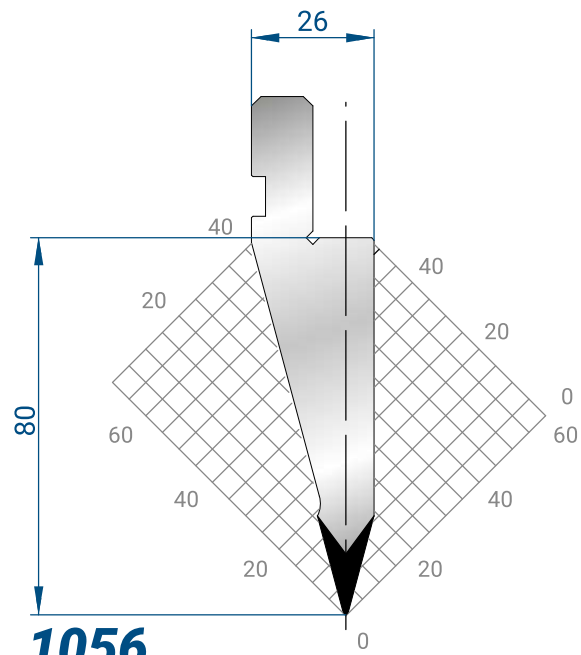

**1056**

Mat = C45  
 H = 80.00  
 Max T/m = 100  
 $\alpha = 30^\circ$   
 R = 0.5

835 mm	10,3 kg
415 mm	5,1 kg
805 mm	9,5 kg
FRAZ. / SECT.	

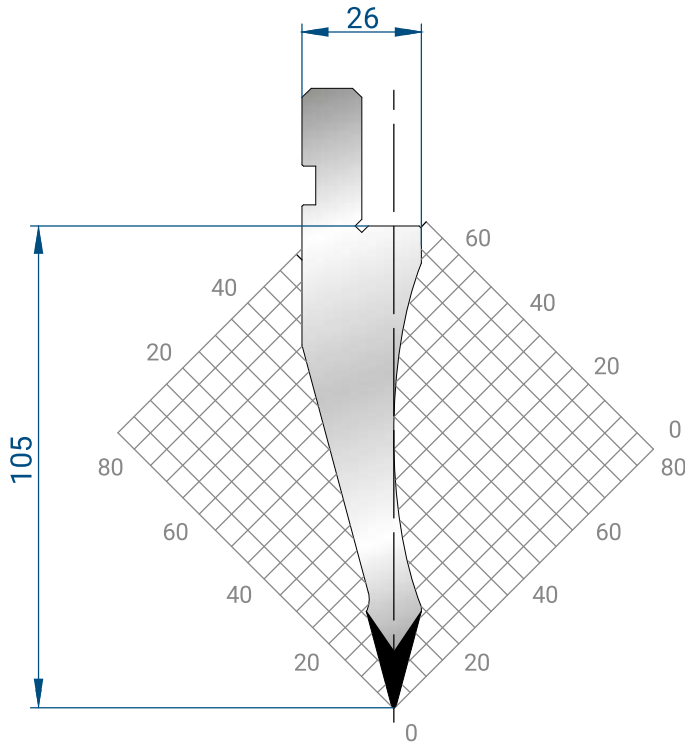

### 1055

Mat = C45  
 H = 105.00  
 Max T/m = 50  
 $\alpha = 30^\circ$   
 R = 0.5

835 mm	12,6 kg
415 mm	6,3 kg
805 mm	11,6 kg
FRAZ. / SECT.	

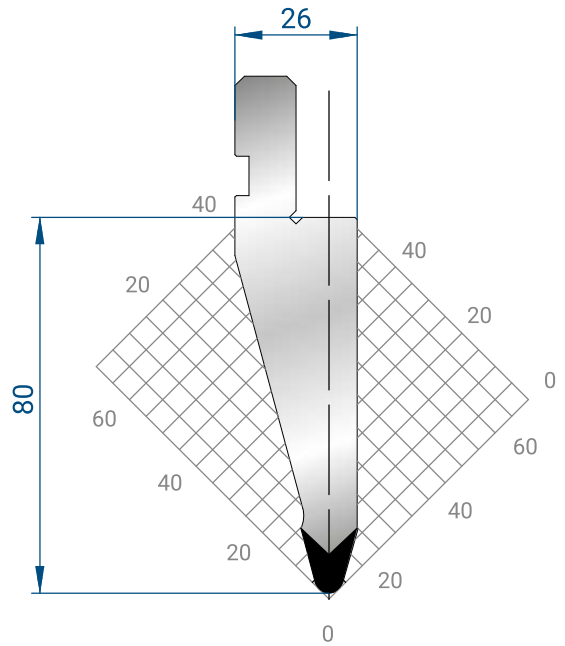

### 1057

Mat = C45  
 H = 80.00  
 Max T/m = 100  
 $\alpha = 30^\circ$   
 R = 3

835 mm	11,4 kg
415 mm	5,7 kg
805 mm	10,5 kg
FRAZ. / SECT.	

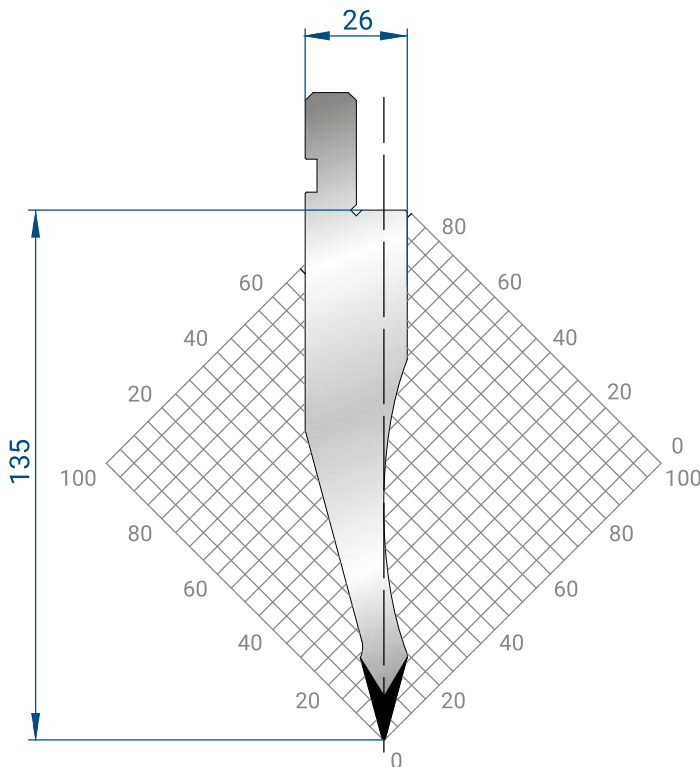

### 1052

Mat = C45  
 H = 135.00  
 Max T/m = 50  
 $\alpha = 30^\circ$   
 R = 0.5

835 mm	17,0 kg
415 mm	8,5 kg
805 mm	15,6 kg
FRAZ. / SECT.	

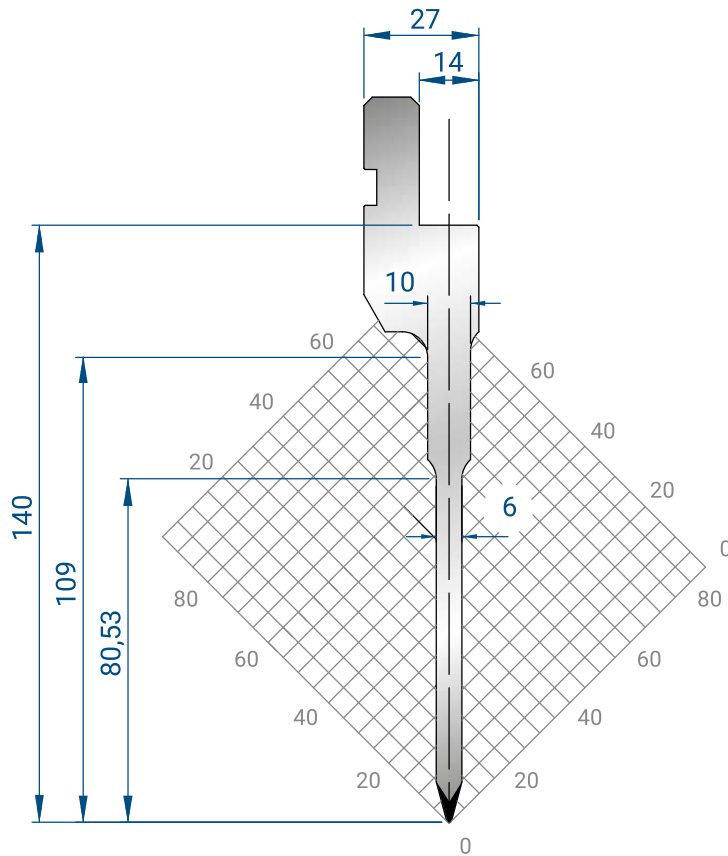

### 1086

Mat = C45  
 bonificato / tempered  
 H = 140.00  
 Max T/m = 40  
 $\alpha = 30^\circ$   
 R = 0.6

835 mm	11,9 kg
415 mm	5,9 kg
805 mm	10,9 kg
FRAZ. / SECT.	

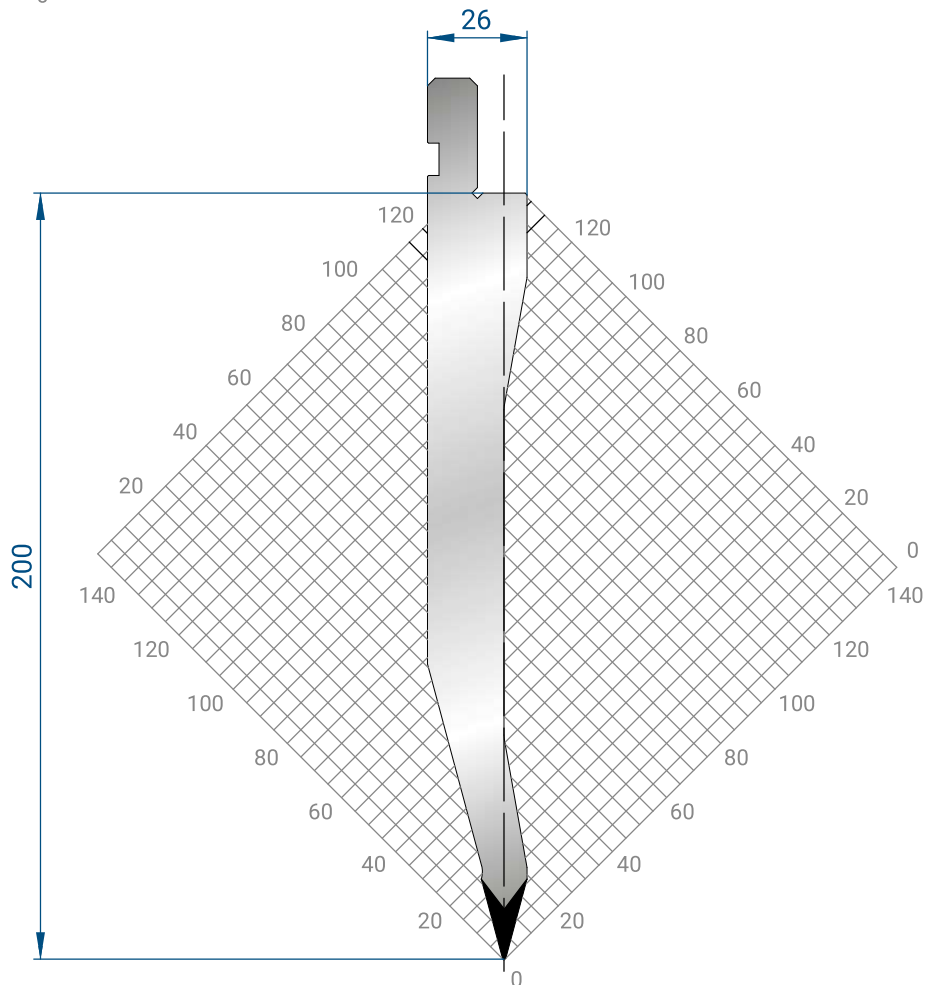

### 1292

Mat = C45  
 H = 200.00  
 Max T/m = 50  
 $\alpha = 30^\circ$   
 R = 0.5

835 mm	25,2 kg
415 mm	12,5 kg
805 mm	23,1 kg
FRAZ. / SECT.	

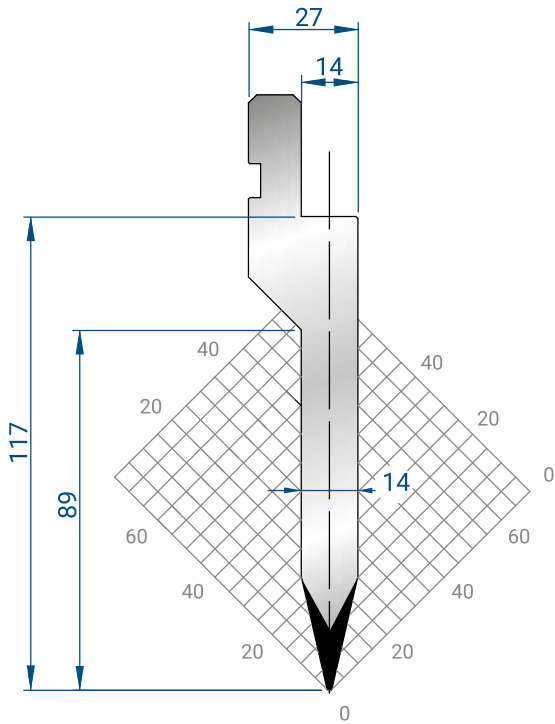

### 1033

Mat = C45  
 H = 117.00  
 Max T/m = 100  
 $\alpha = 26^\circ$   
 P = 1

835 mm	13,7 kg
415 mm	6,8 kg
805 mm FRAZ. / SECT.	12,6 kg

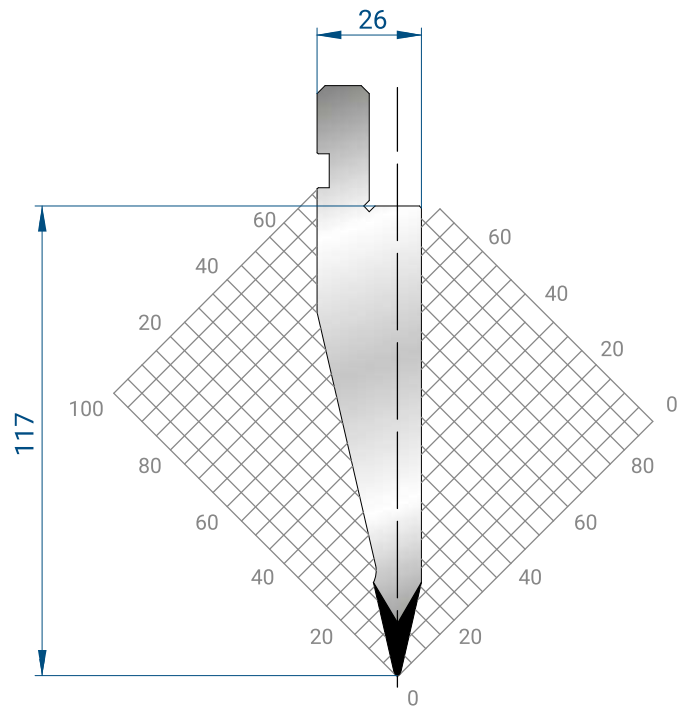

### 1178

Mat = C45  
 H = 117.00  
 Max T/m = 100  
 $\alpha = 26^\circ$   
 R = 0.8

835 mm	15,9 kg
415 mm	7,9 kg
805 mm FRAZ. / SECT.	14,6 kg

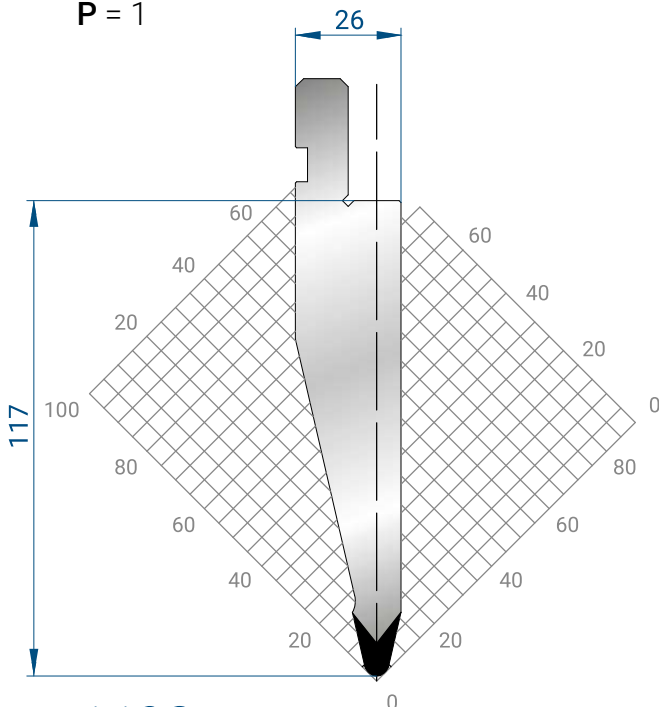

### 1192

Mat = C45  
 H = 117.00  
 Max T/m = 100  
 $\alpha = 26^\circ$   
 R = 3

835 mm	17,0 kg
415 mm	8,5 kg
805 mm FRAZ. / SECT.	15,6 kg

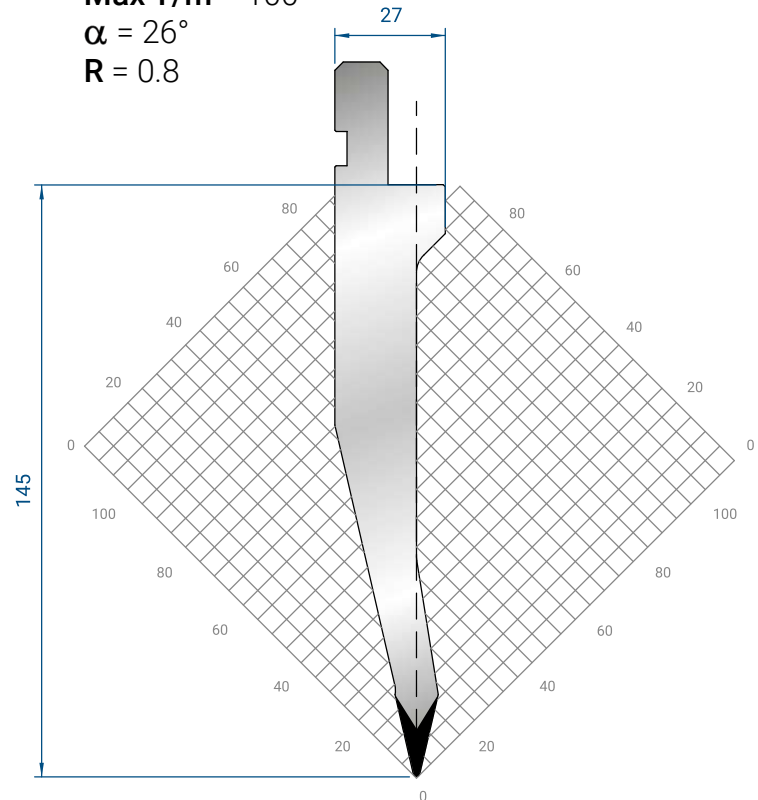

### 1311

Mat = 42CrMo4 bonificato / tempered  
 H = 145.00  
 Max T/m = 100  
 $\alpha = 26^\circ$   
 R = 0.8

835 mm	16,8 kg
415 mm	8,3 kg
805 mm FRAZ. / SECT.	15,3 kg



VEDI PAG. 16 PER SCHEMA FRAZIONATURA PUNZONI  
SEE PAGE 16 FOR PUNCHES SEGMENTATION DIAGRAM

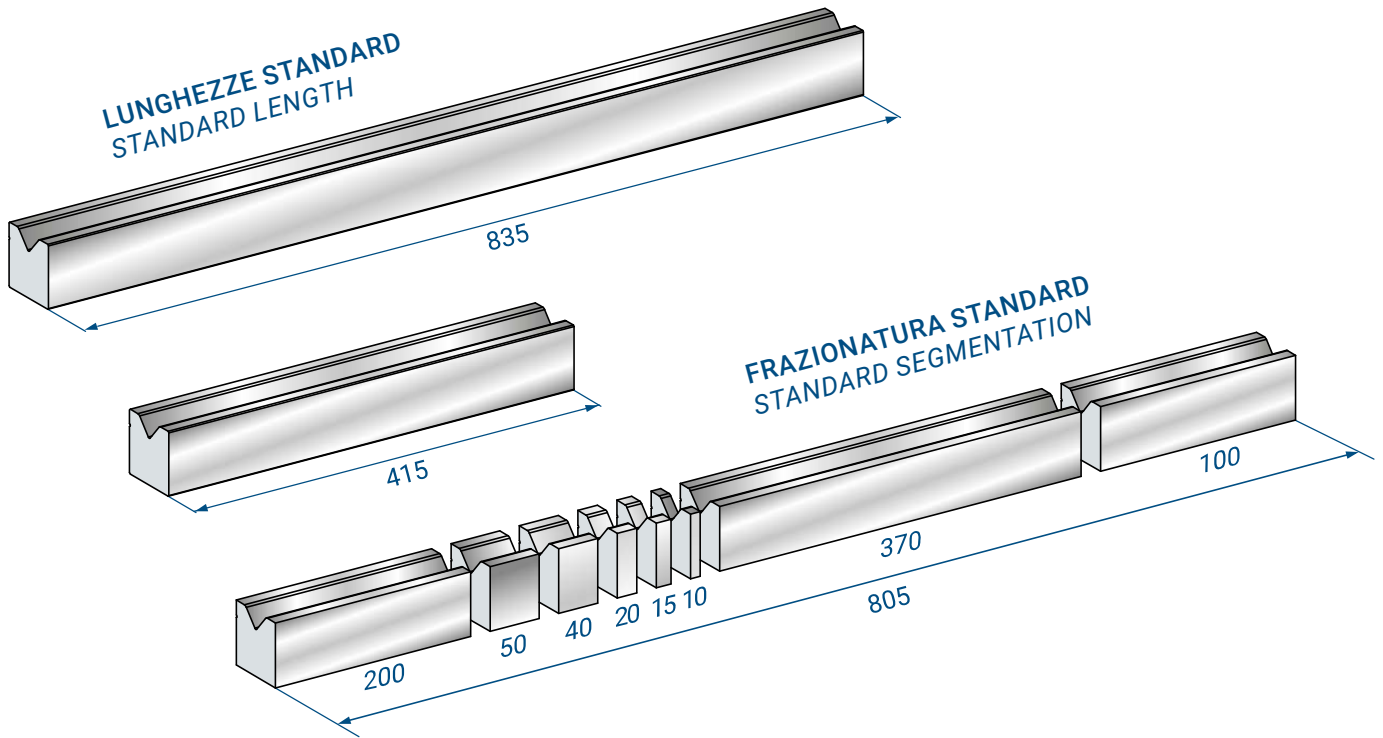

TEMPRATO AD INDUZIONE  
INDUCTION HARDENED

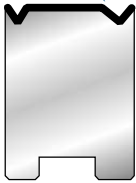

TEMPRATO AD INDUZIONE  
INDUCTION HARDENED

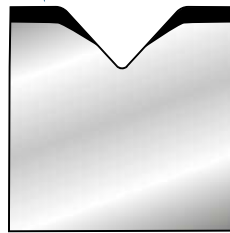

TEMPRATO AD INDUZIONE  
INDUCTION HARDENED

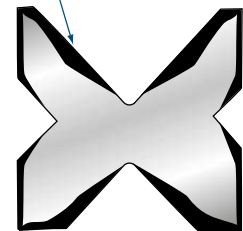

TEMPRATO AD INDUZIONE  
INDUCTION HARDENED



TEMPRATO AD INDUZIONE  
INDUCTION HARDENED

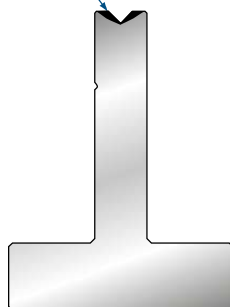

**TAGLI A RICHIESTA**  
**SPECIAL SEGMENTATION**

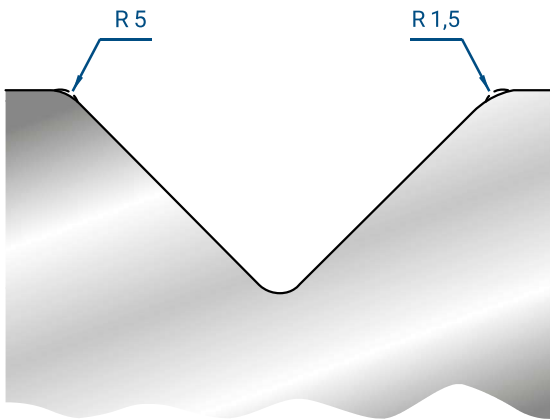
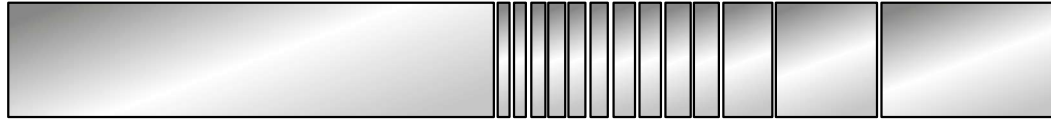

**MODIFICA RAGGIO**  
**RADIUS MODIFICATION**

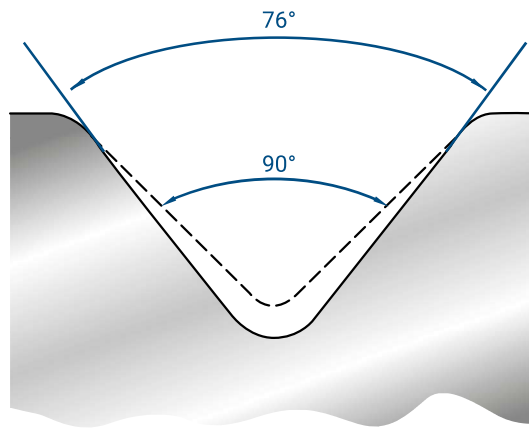

**MODIFICA ANGOLO**  
**ANGLE MODIFICATION**



**SUPPORTI PER MATRICI 2V**  
**DIE HOLDERS FOR 2V DIES**

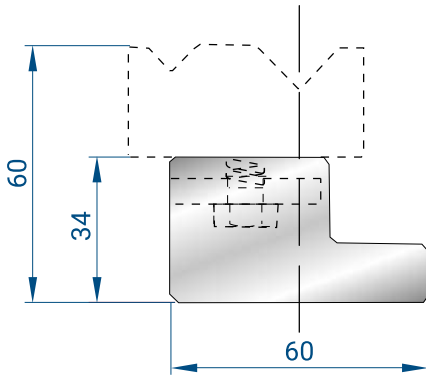

**2018**

Mat = C45

830 mm	9,3 kg
410 mm	4,6 kg

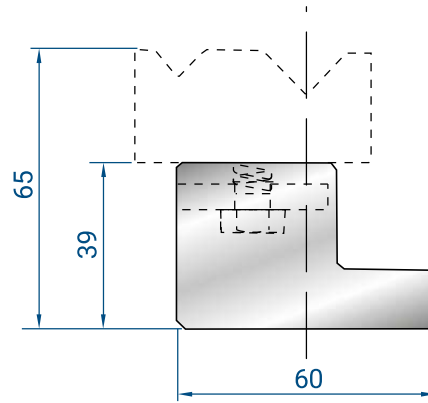

**2039**

Mat = C45

830 mm	10,4 kg
410 mm	5,1 kg

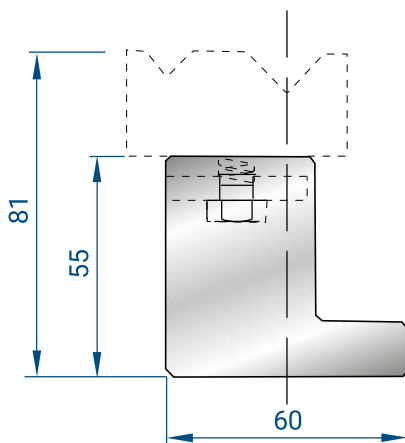

**2019**

Mat = C45

830 mm	13,2 kg
410 mm	6,5 kg

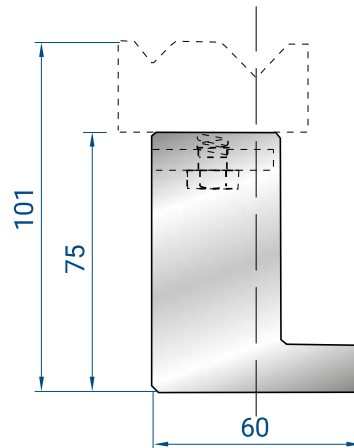

**2035**

Mat = C45

830 mm	18,0 kg
410 mm	8,9 kg

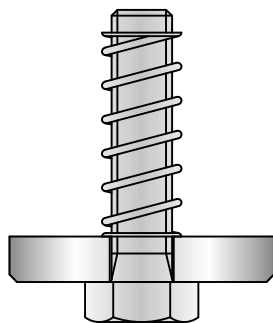

**4277**

**MOLLA + RONDELLA + VITE**  
**SPRING + WASHER + SCREW**

# SUPPORTI PER MATRICI AUTOCENTRANTI DIE HOLDERS FOR SELF-CENTERING DIES

## SUPPORTI PER MATRICI AUTOCENTRANTI DIE HOLDERS FOR SELF-CENTERING DIES

DEVE ESSERE INSTALLATO  
SUI SUPPORTI MODELLO:

MUST BE INSTALLED ON  
SUPPORT MODEL:

2018 - 2019 - 2035 - 2039

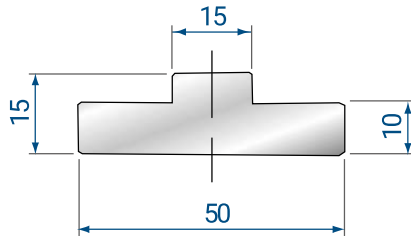

**2058**

Mat = C45

830 mm	3,7 kg
410 mm	1,8 kg

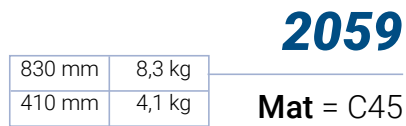

**2059**

Mat = C45

830 mm	8,3 kg
410 mm	4,1 kg

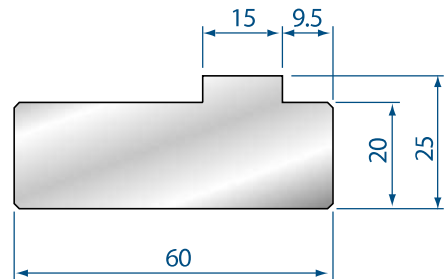

## FERMO PER MATRICI AUTOCENTRANTI FIXED BAR FOR SELF-CENTERING DIES

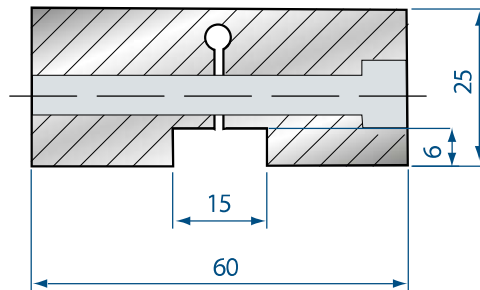

**2060**

Mat = C45

15 mm	0,2 kg
-------	--------

## ESEMPIO DI MONTAGGIO ASSEMBLY EXAMPLE

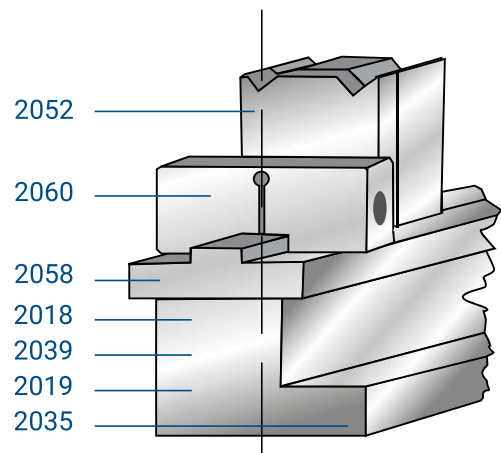

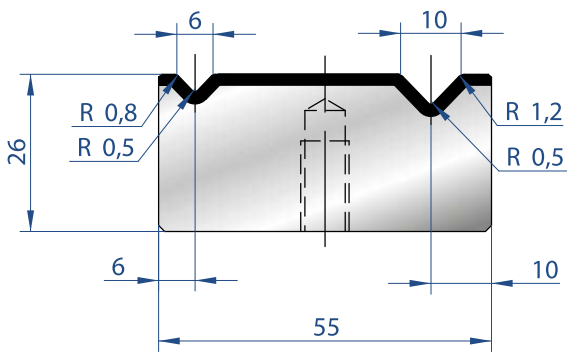

**2046**

Mat = C45  
 Max T/m = 100  
 $\alpha = 88^\circ$

835 mm	9,1 kg
415 mm	4,5 kg

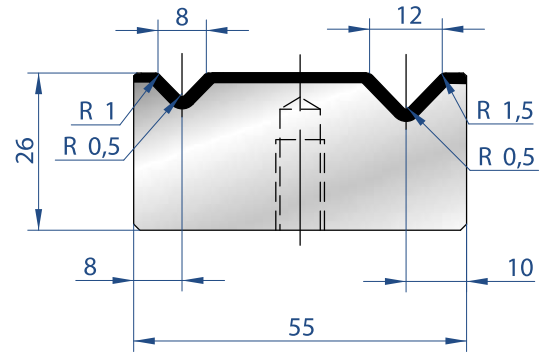

**2041**

Mat = C45  
 Max T/m = 100  
 $\alpha = 88^\circ$

835 mm	9,0 kg
415 mm	4,5 kg

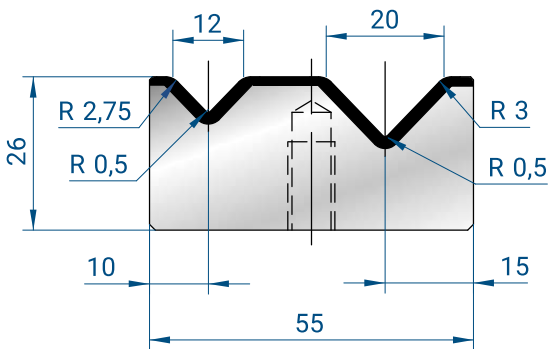

**2013**

Mat = C45  
 Max T/m = 100  
 $\alpha = 88^\circ$

835 mm	8,4 kg
415 mm	4,2 kg

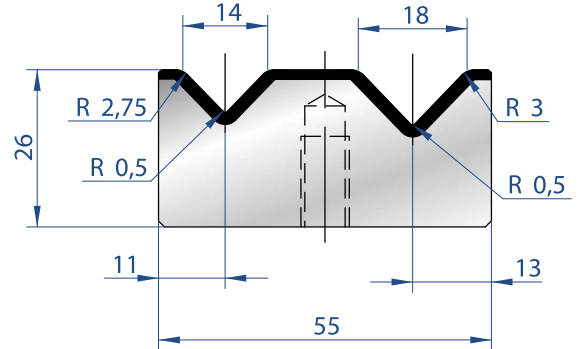

**2032**

Mat = C45  
 Max T/m = 100  
 $\alpha = 88^\circ$

835 mm	8,4 kg
415 mm	4,2 kg

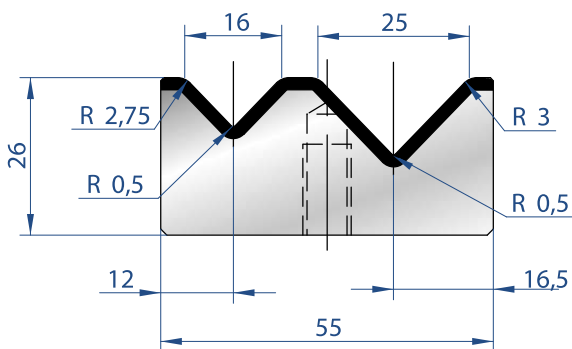

**2014**

Mat = C45  
 Max T/m = 100  
 $\alpha = 88^\circ$

835 mm	7,8 kg
415 mm	3,9 kg

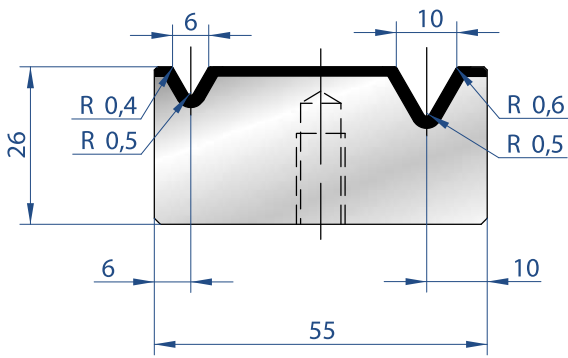

**2015**

Mat = C45  
Max T/m = 60  
 $\alpha = 60^\circ$

835 mm	8,9 kg
415 mm	4,4 kg

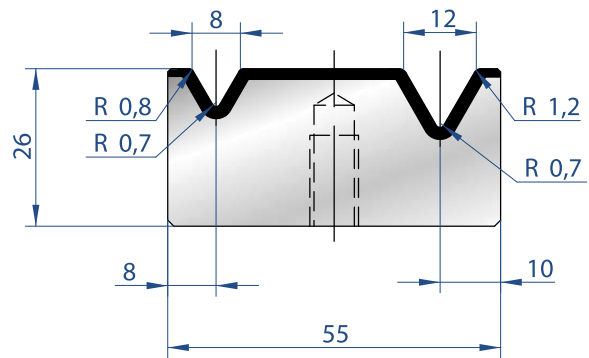

**2016**

Mat = C45  
Max T/m = 60  
 $\alpha = 60^\circ$

835 mm	8,7 kg
415 mm	4,3 kg

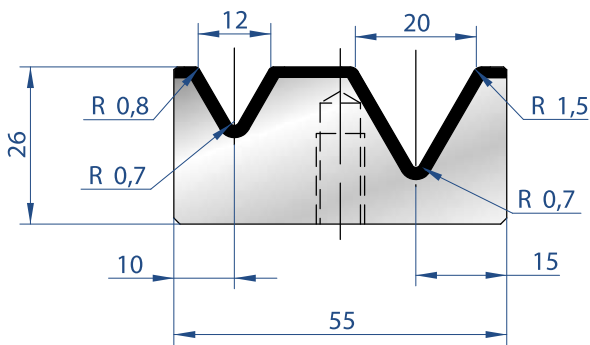

**2033**

Mat = C45  
Max T/m = 60  
 $\alpha = 60^\circ$

835 mm	7,8 kg
415 mm	3,9 kg

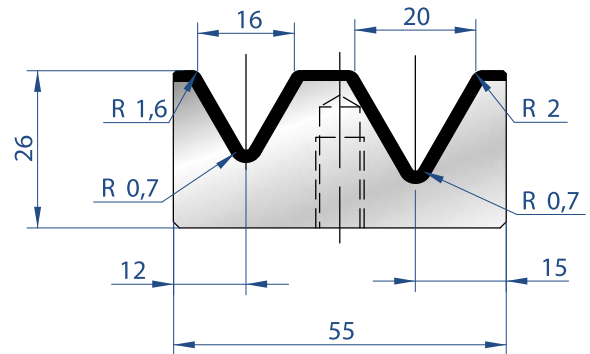

**2017**

Mat = C45  
Max T/m = 60  
 $\alpha = 60^\circ$

835 mm	7,5 kg
415 mm	3,7 kg

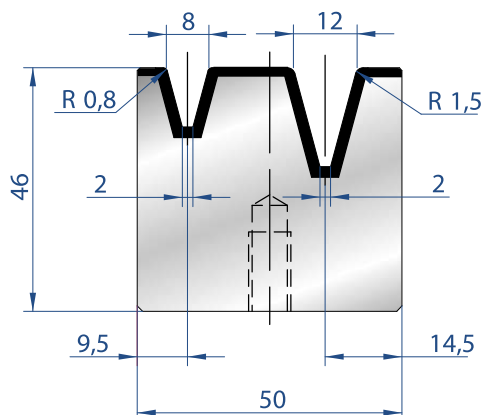

**2047**

Mat = C45  
Max T/m = 40  
 $\alpha = 30^\circ$

835 mm	13,8 kg
415 mm	6,9 kg

**MATRICI 2V AUTOCENTRANTI - 88°**  
**2V SELF-CENTERING DIES - 88°**

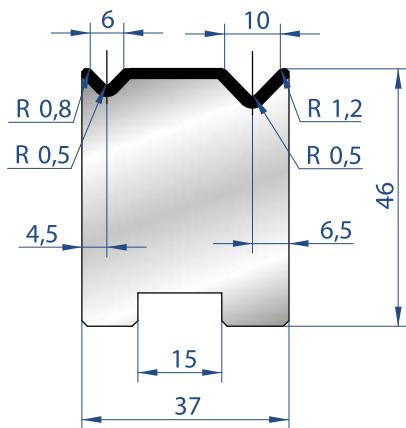

**2050**

**Mat = C45**  
**Max T/m = 80**  
 $\alpha = 88^\circ$

835 mm	10,3 kg
415 mm	5,1 kg
805 mm	9,9 kg
FRAZ. / SECT.	

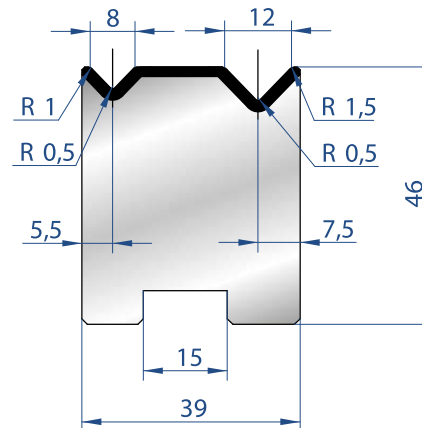

**2052**

**Mat = C45**  
**Max T/m = 80**  
 $\alpha = 88^\circ$

835 mm	10,8 kg
415 mm	5,4 kg
805 mm	10,4 kg
FRAZ. / SECT.	

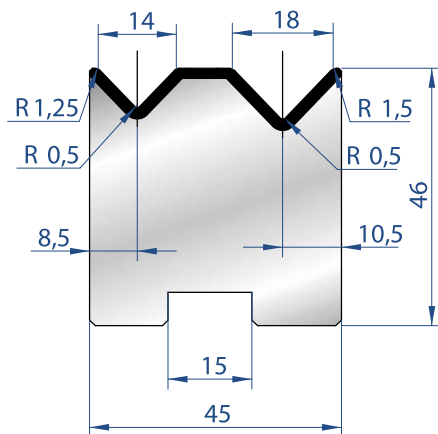

**2053**

**Mat = C45**  
**Max T/m = 80**  
 $\alpha = 88^\circ$

835 mm	12,1 kg
415 mm	6,0 kg
805 mm	11,6 kg
FRAZ. / SECT.	

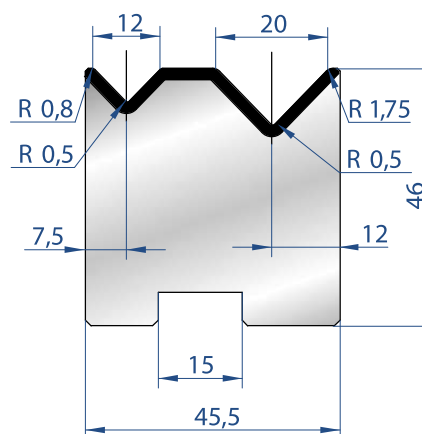

**2054**

**Mat = C45**  
**Max T/m = 80**  
 $\alpha = 88^\circ$

835 mm	12,1 kg
415 mm	6,0 kg
805 mm	11,7 kg
FRAZ. / SECT.	

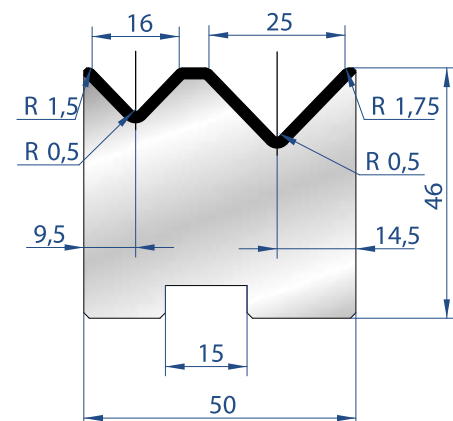

**2055**

**Mat = C45**  
**Max T/m = 80**  
 $\alpha = 88^\circ$

835 mm	13,0 kg
415 mm	6,4 kg
805 mm	12,5 kg
FRAZ. / SECT.	

**MATRICI 2V AUTOCENTRANTI - 30°**  
**2V SELF-CENTERING DIES - 30°**

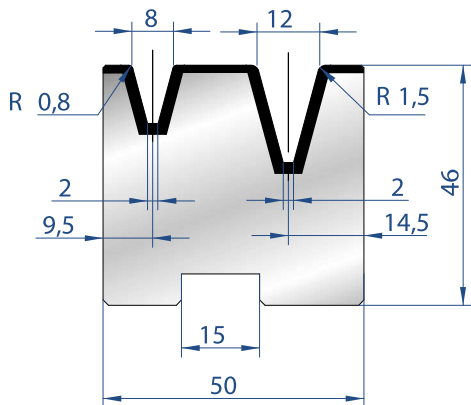

**2056**

**Mat = C45**  
**Max T/m = 40**  
 **$\alpha = 30^\circ$**

835 mm	13,2 kg
415 mm	6,6 kg
805 mm FRAZ. / SECT.	12,7 kg

**MATRICI 3U / 3U DIES**

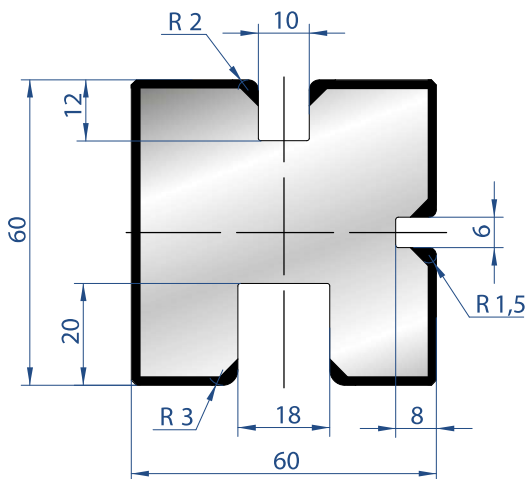

**2031**

**Mat = C45**  
**Max T/m = 100**

835 mm	20,0 kg
415 mm	10,0 kg
805 mm FRAZ. / SECT.	19,3 kg



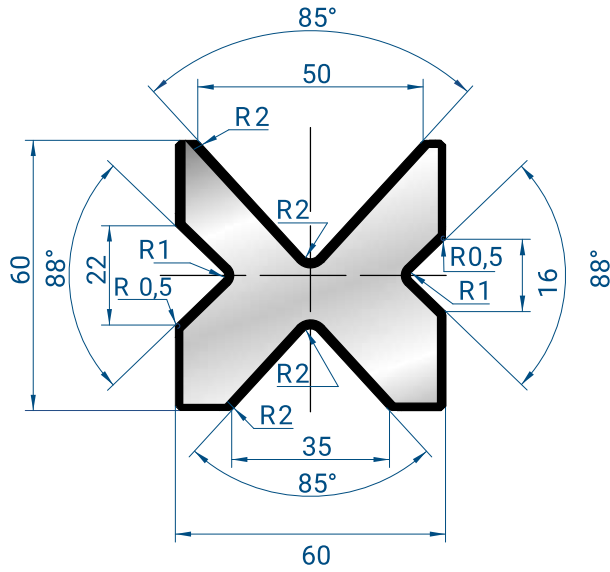

## 2030

Mat = C45  
Max T/m = 80  
 $\alpha = 85^\circ - 88^\circ$

835 mm	15,7 kg
415 mm	7,8 kg
805 mm FRAZ. / SECT.	15,1 kg

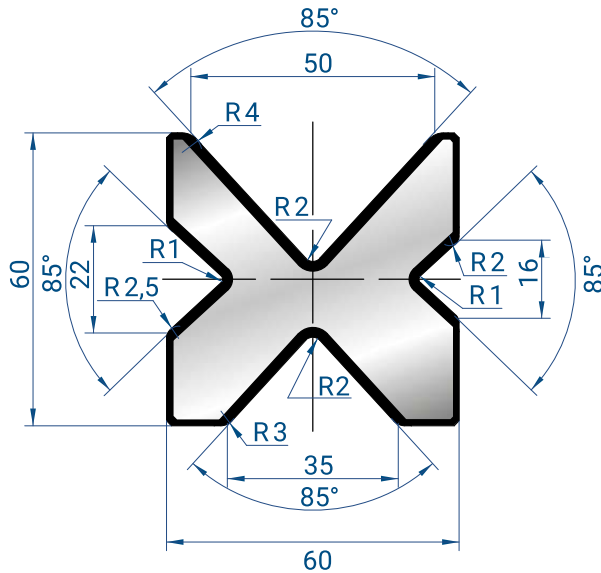

## 2067

Mat = C45  
Max T/m = 80  
 $\alpha = 85^\circ$

835 mm	15,6 kg
415 mm	7,7 kg
805 mm FRAZ. / SECT.	15,0 kg

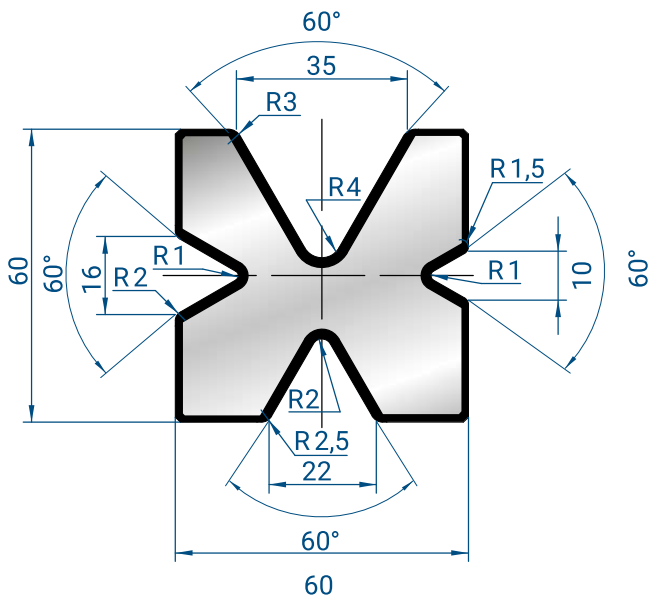

## 2034

Mat = C45  
Max T/m = 60  
 $\alpha = 60^\circ$

835 mm	17,8 kg
415 mm	8,8 kg
805 mm FRAZ. / SECT.	17,1 kg

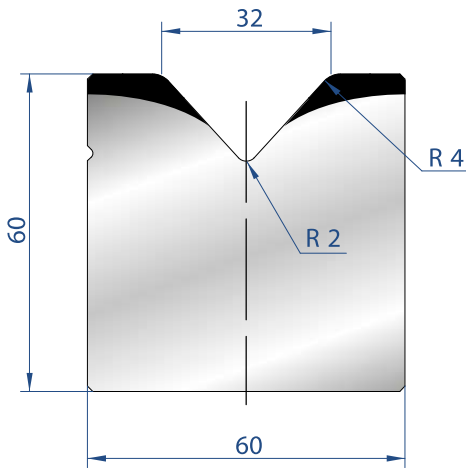

**2020**

Mat = C45  
Max T/m = 100  
 $\alpha = 85^\circ$

835 mm	21,7 kg
415 mm	10,8 kg
805 mm	20,9 kg
FRAZ. / SECT.	

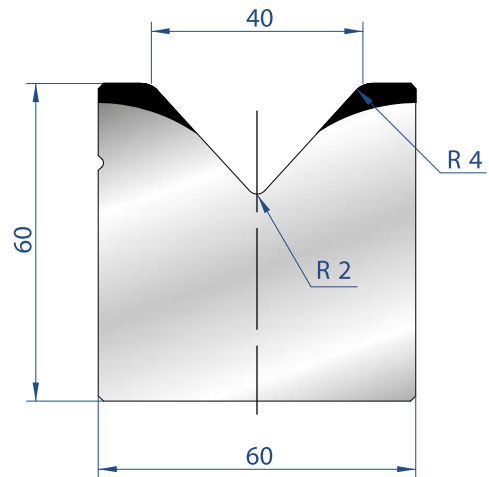

**2021**

Mat = C45  
Max T/m = 100  
 $\alpha = 85^\circ$

835 mm	20,7 kg
415 mm	10,3 kg
805 mm	19,9 kg
FRAZ. / SECT.	

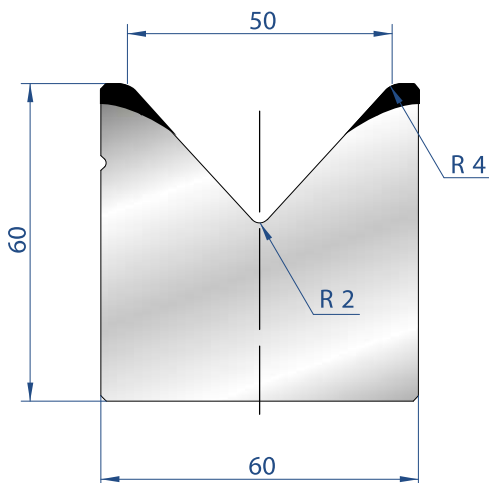

**2022**

Mat = C45  
Max T/m = 100  
 $\alpha = 85^\circ$

835 mm	19,1 kg
415 mm	9,5 kg
805 mm	18,4 kg
FRAZ. / SECT.	

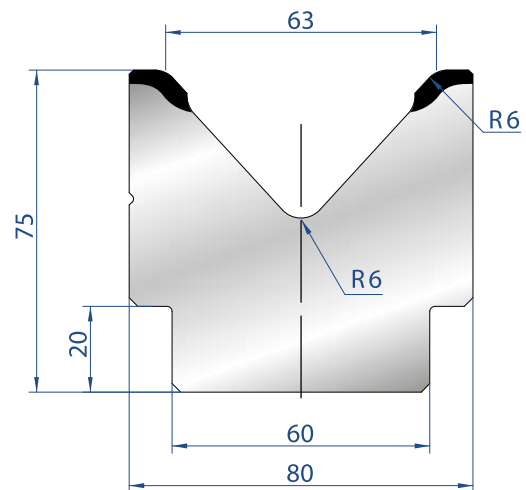

**2023**

Mat = C45  
Max T/m = 100  
 $\alpha = 85^\circ$

835 mm	28,5 kg
415 mm	14,2 kg
805 mm	27,5 kg
FRAZ. / SECT.	

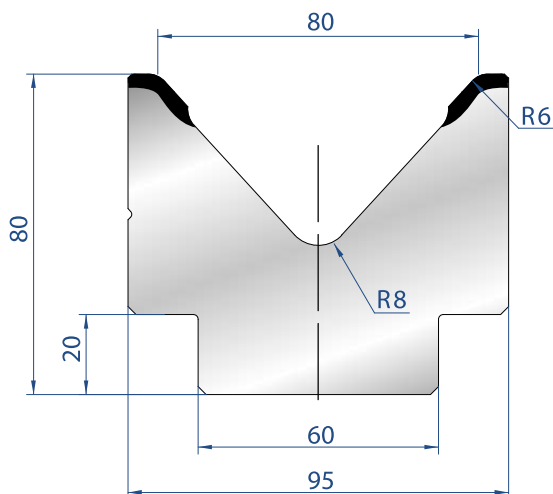

**2024**

Mat = C45  
Max T/m = 100  
 $\alpha = 85^\circ$

835 mm	32,5 kg
415 mm	16,1 kg
805 mm	31,3 kg
FRAZ. / SECT.	

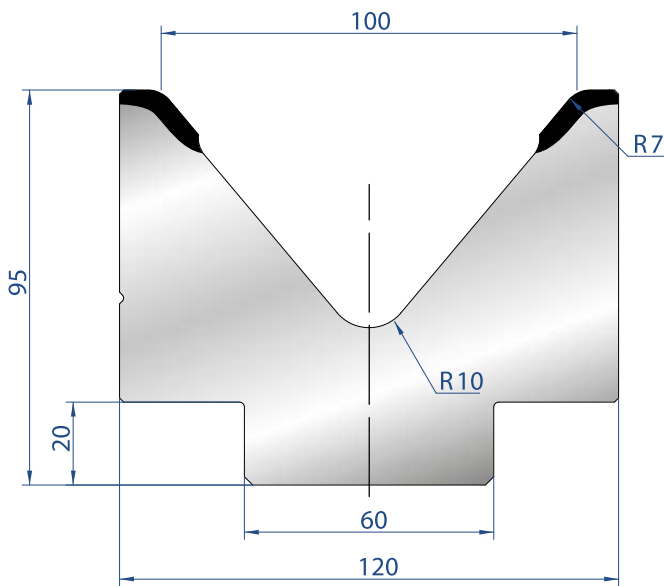

### 2025

Mat = C45

Max T/m = 120

$\alpha = 80^\circ$

835 mm	45,7 kg
415 mm	22,7 kg
805 mm	44,1 kg
FRAZ. / SECT.	

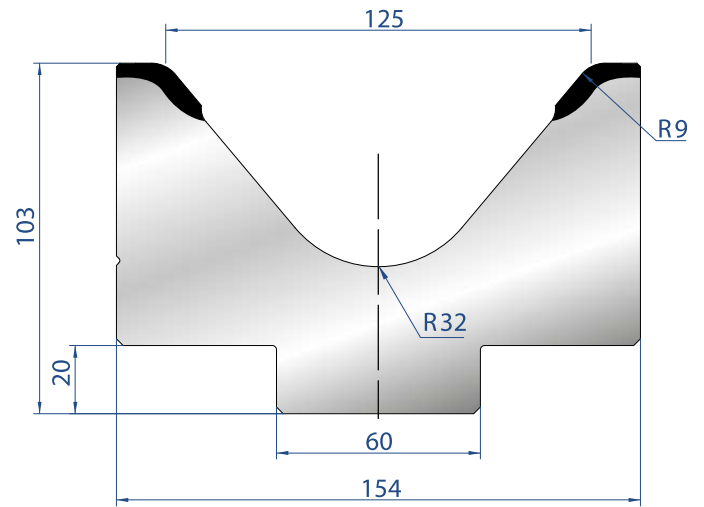

### 2026

Mat = C45

Max T/m = 120

$\alpha = 80^\circ$

835 mm	60,9 kg
415 mm	30,3 kg
805 mm	58,7 kg
FRAZ. / SECT.	

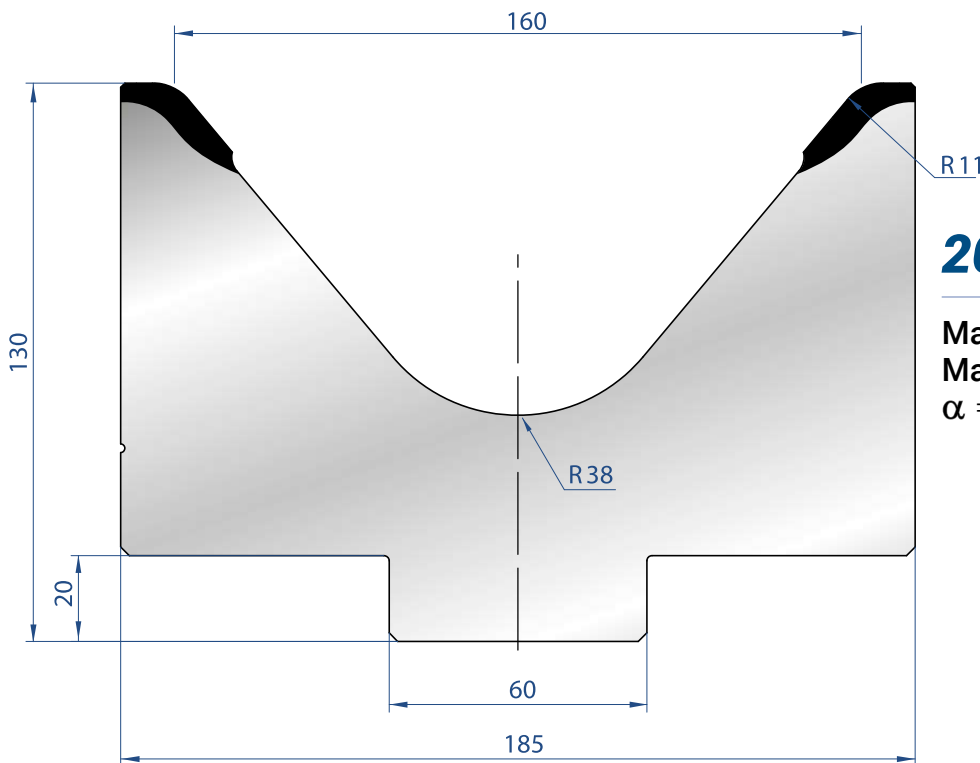

### 2027

Mat = C45

Max T/m = 120

$\alpha = 80^\circ$

835 mm	91,3 kg
415 mm	45,4 kg
805 mm	88,0 kg
FRAZ. / SECT.	

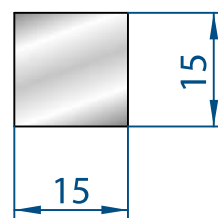

### 8106

TRAFILATI 15X15  
SQUARE BAR 15X15

835 mm	2,9 kg
--------	--------

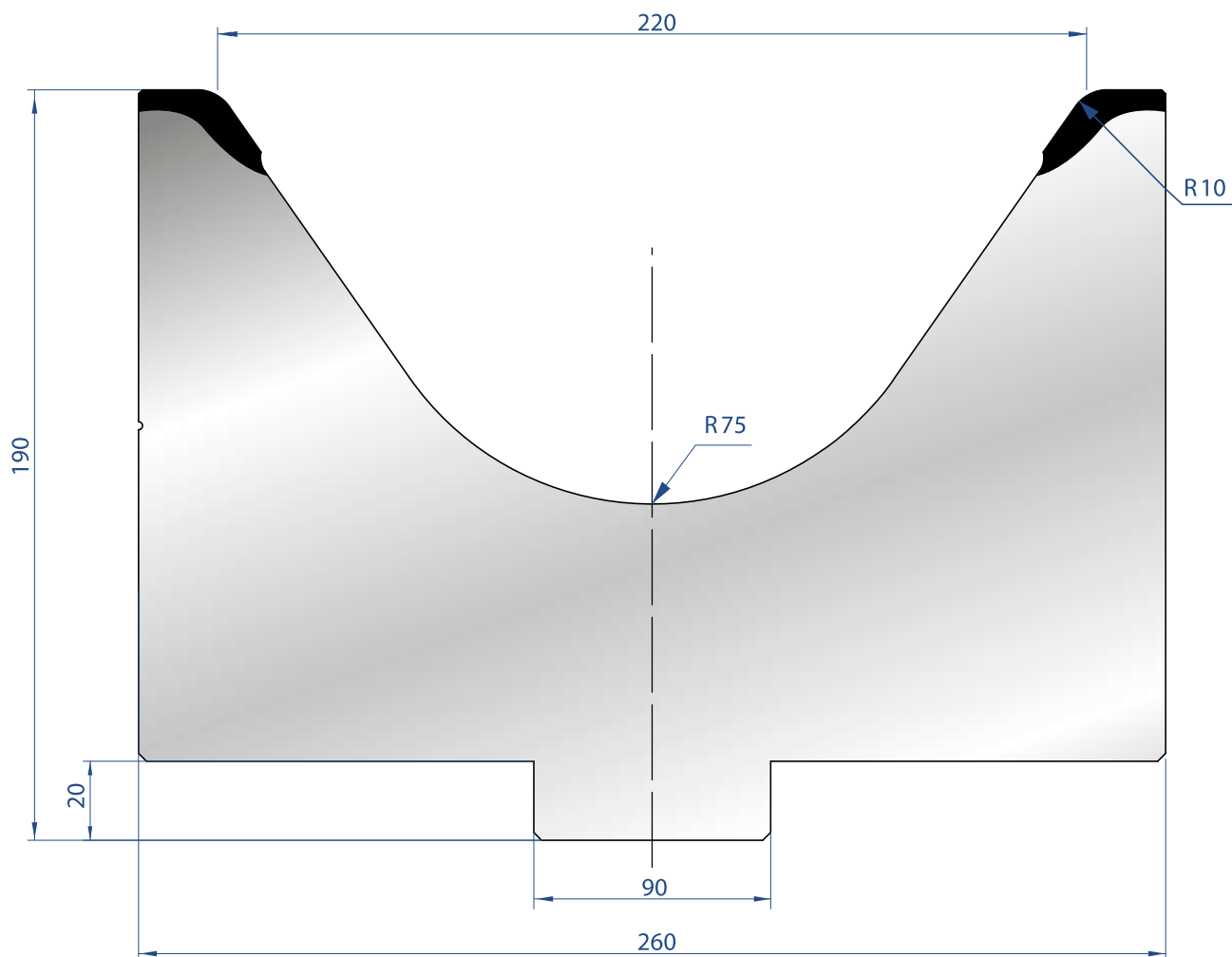

## 7290

505 mm 121,2 kg

**Mat** = C45  
 bonificato /  
 tempered  
**Max T/m** = 200  
 $\alpha = 70^\circ$

SOLO LUNGHEZZA  
 505 MM  
 AVAILABLE ONLY  
 LENGHT 505 MM

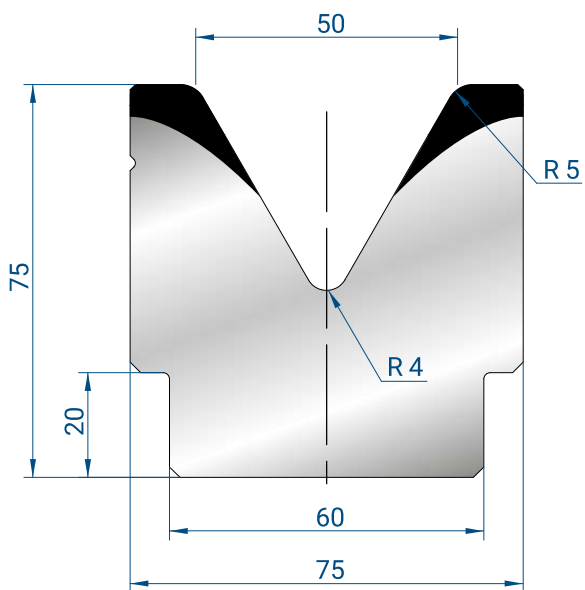

**2082**

Mat = C45  
 Max T/m = 100  
 $\alpha = 60^\circ$

835 mm	27,7 kg
415 mm	13,8 kg
805 mm FRAZ. / SECT.	26,7 kg

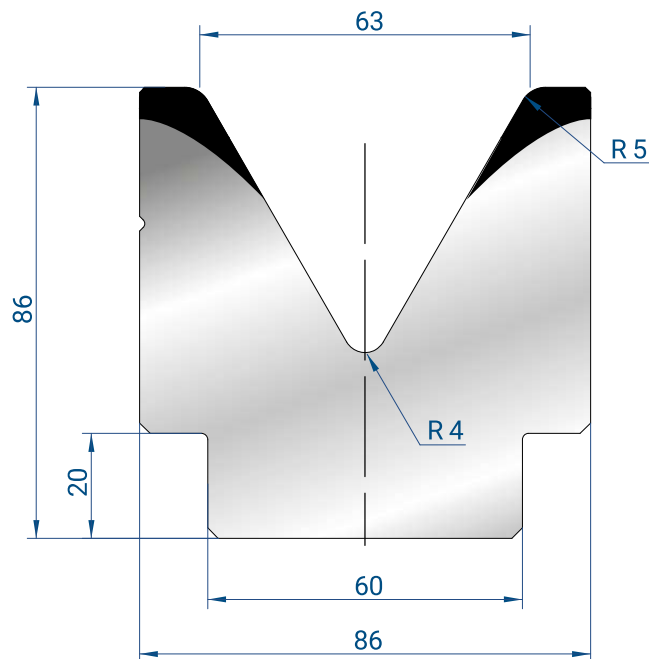

**2083**

Mat = C45  
 Max T/m = 100  
 $\alpha = 60^\circ$

835 mm	33,7 kg
415 mm	16,8 kg
805 mm FRAZ. / SECT.	32,5 kg

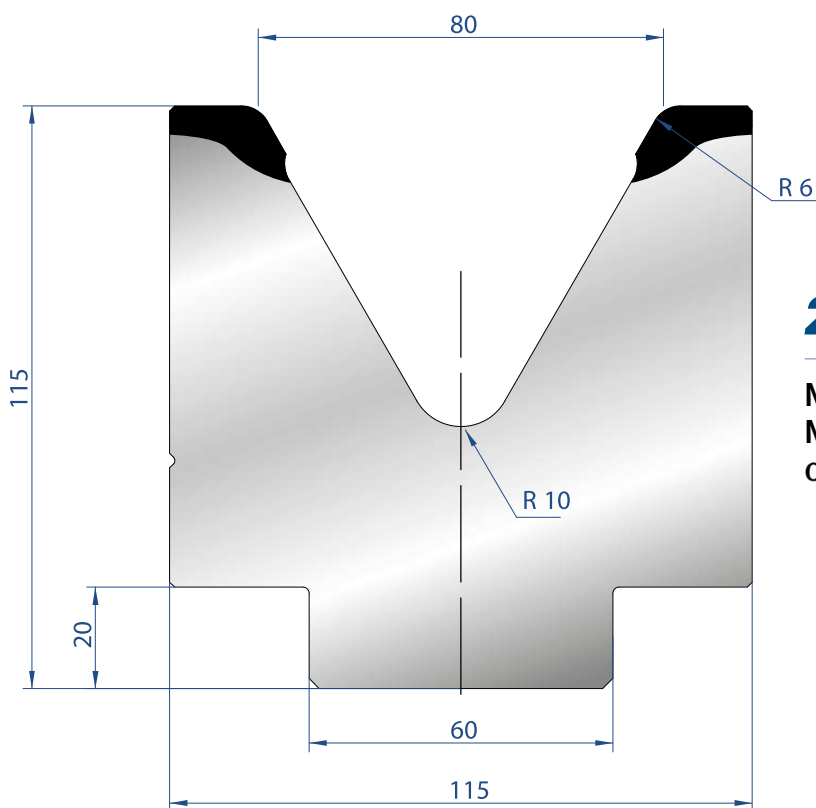

**2089**

Mat = C45  
 Max T/m = 100  
 $\alpha = 60^\circ$

835 mm	59,7 kg
415 mm	29,7 kg
805 mm FRAZ. / SECT.	57,6 kg

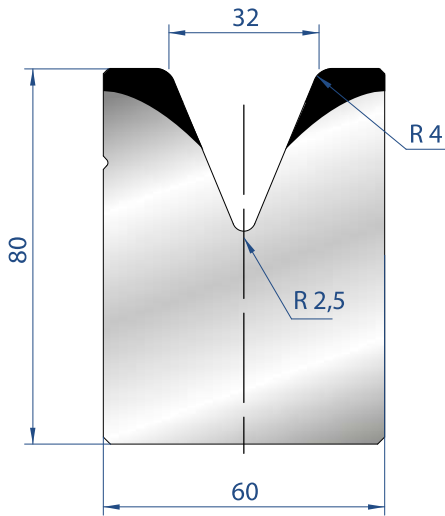

**2088**

Mat = C45  
Max T/m = 100  
 $\alpha = 45^\circ$

835 mm	27,4 kg
415 mm	13,6 kg
805 mm FRAZ. / SECT.	26,4 kg

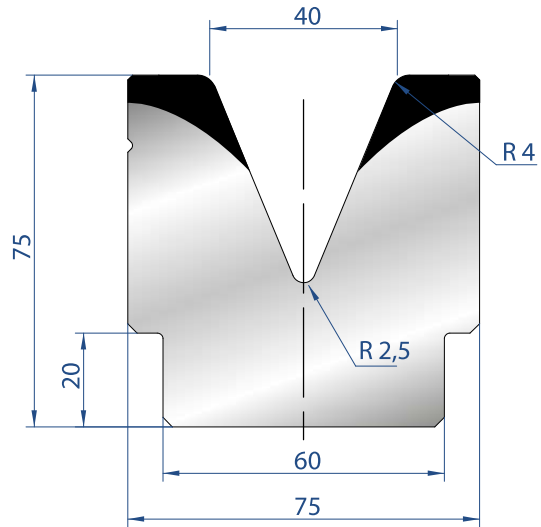

**2081**

Mat = C45  
Max T/m = 100  
 $\alpha = 45^\circ$

835 mm	28,5 kg
415 mm	14,2 kg
805 mm FRAZ. / SECT.	27,5 kg

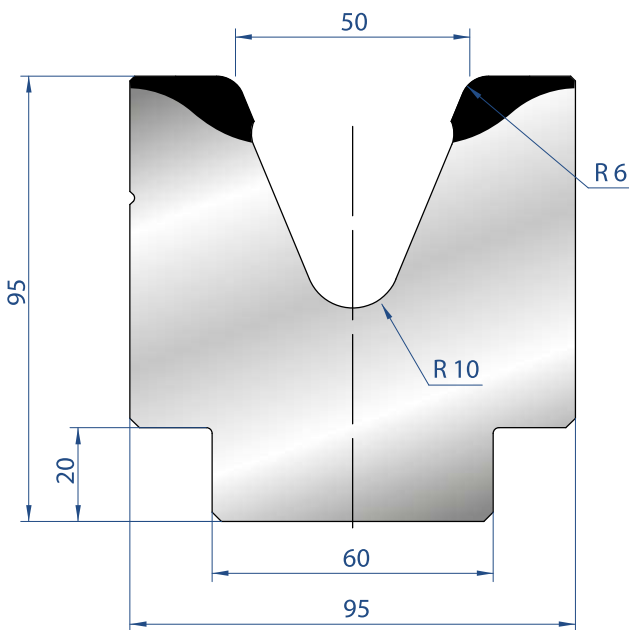

**2118**

Mat = C45  
Max T/m = 100  
 $\alpha = 45^\circ$

835 mm	43,8 kg
415 mm	21,8 kg
805 mm FRAZ. / SECT.	42,2 kg

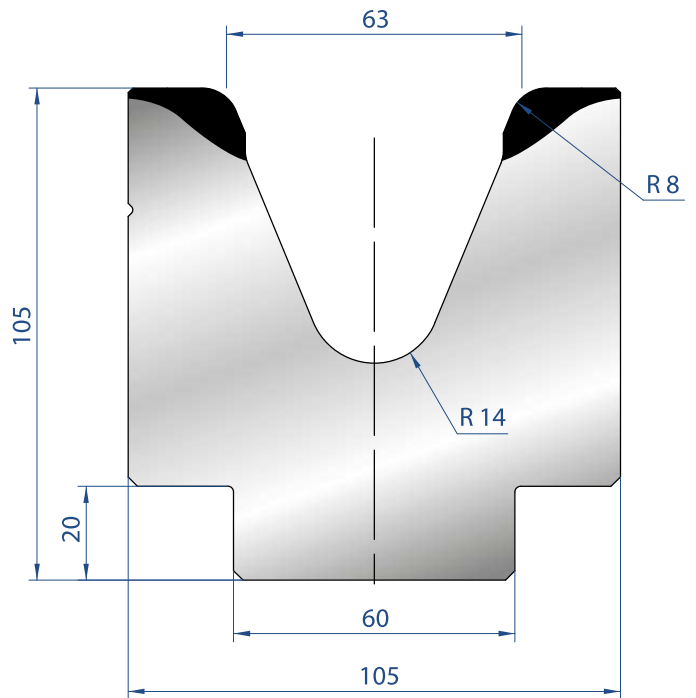

**2117**

Mat = C45  
Max T/m = 100  
 $\alpha = 45^\circ$

835 mm	50,1 kg
415 mm	24,9 kg
805 mm FRAZ. / SECT.	48,3 kg

**MATRICI 1V - 45° / 1V DIES - 45°**

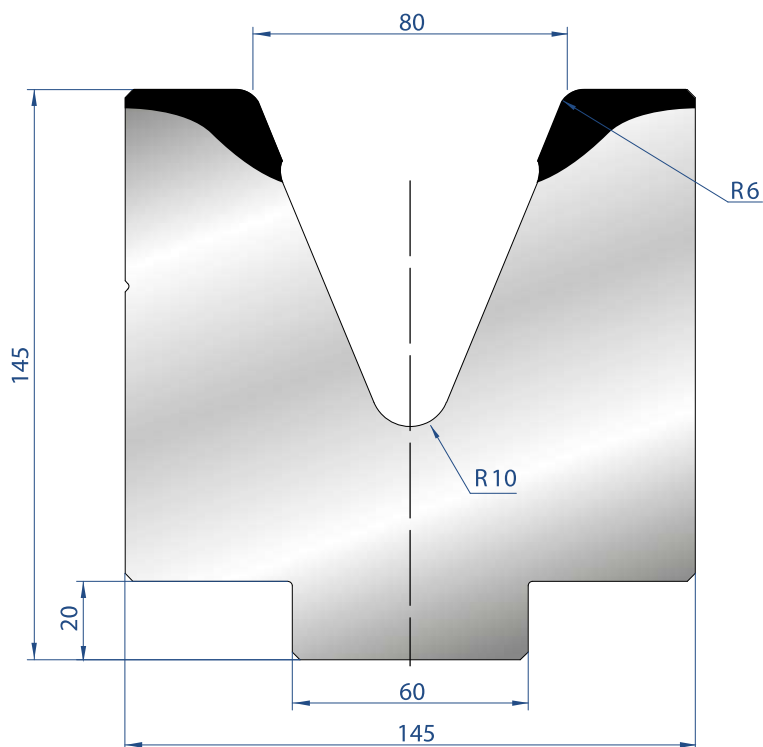

**2084**

Mat = C45  
Max T/m = 100  
 $\alpha = 45^\circ$

835 mm	99,6 kg
415 mm	49,5 kg
805 mm FRAZ. / SECT.	96,0 kg

**MATRICI 1V - 30° / 1V DIES - 30°**

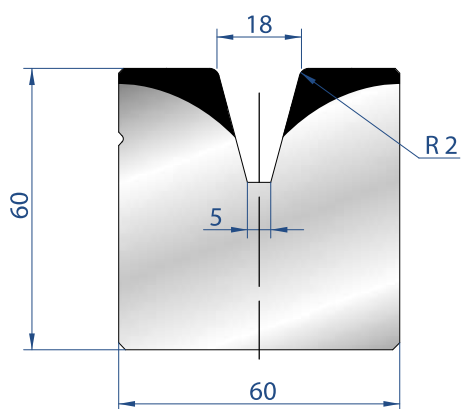

**2086**

Mat = C45  
Max T/m = 100  
 $\alpha = 30^\circ$

835 mm	21,7 kg
415 mm	10,8 kg
805 mm FRAZ. / SECT.	20,9 kg

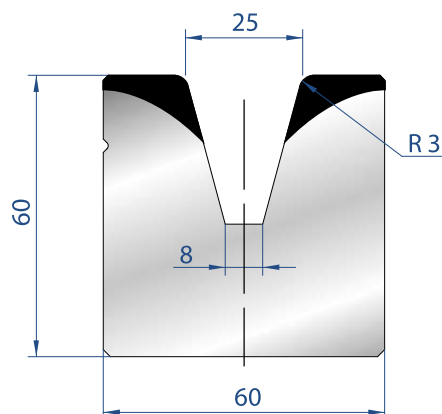

**2087**

Mat = C45  
Max T/m = 100  
 $\alpha = 30^\circ$

835 mm	20,1 kg
415 mm	10,0 kg
805 mm FRAZ. / SECT.	19,4 kg



 **EUROSTAMP TOC**  
the Italian excell

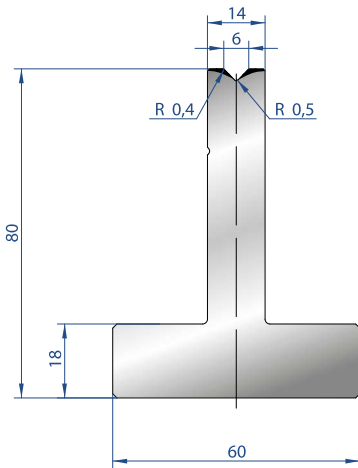

**3080**

835 mm	12,7 kg	<b>Mat = C45</b> <b>Max T/m = 100</b> <b>α = 88°</b>
415 mm	6,3 kg	
805 mm FRAZ. / SECT.	12,2 kg	

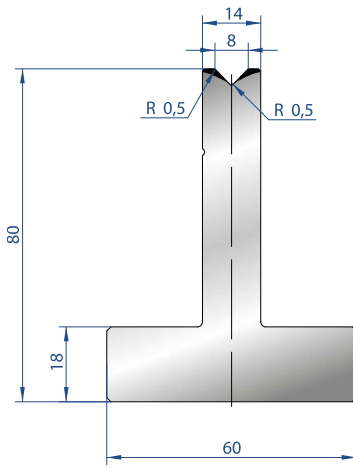

**3081**

835 mm	12,6 kg	<b>Mat = C45</b> <b>Max T/m = 100</b> <b>α = 88°</b>
415 mm	6,3 kg	
805 mm FRAZ. / SECT.	12,2 kg	

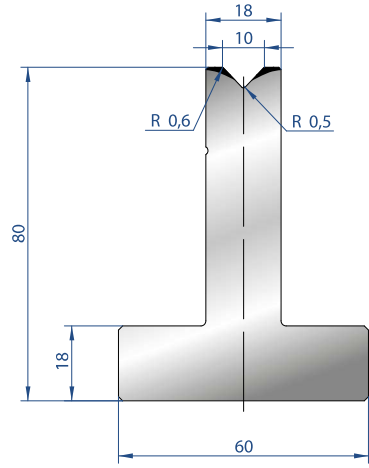

**3082**

835 mm	14,2 kg	<b>Mat = C45</b> <b>Max T/m = 100</b> <b>α = 88°</b>
415 mm	7,0 kg	
805 mm FRAZ. / SECT.	13,7 kg	

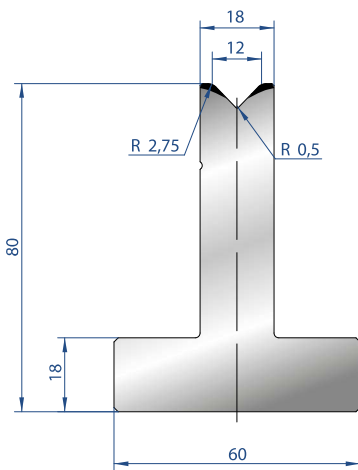

**3015**

835 mm	14,1 kg	<b>Mat = C45</b> <b>Max T/m = 100</b> <b>α = 88°</b>
415 mm	7,0 kg	
805 mm FRAZ. / SECT.	13,6 kg	

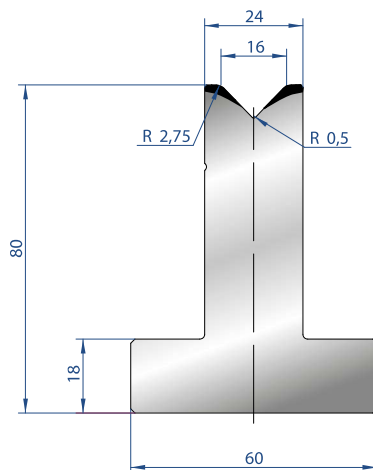

**3016**

835 mm	16,3 kg	<b>Mat = C45</b> <b>Max T/m = 100</b> <b>α = 88°</b>
415 mm	8,1 kg	
805 mm FRAZ. / SECT.	15,8 kg	

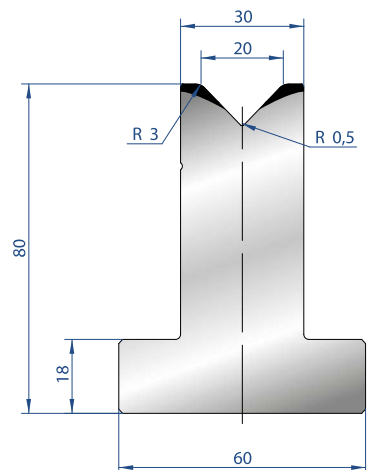

**3017**

835 mm	18,5 kg	<b>Mat = C45</b> <b>Max T/m = 100</b> <b>α = 88°</b>
415 mm	9,2 kg	
805 mm FRAZ. / SECT.	17,9 kg	



**3018**

835 mm	20,2 kg
415 mm	10,0 kg
805 mm FRAZ. / SECT.	19,5 kg

**Mat = C45**  
**Max T/m = 100**  
**α = 88°**

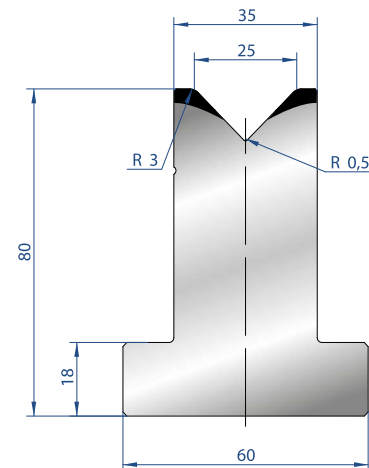

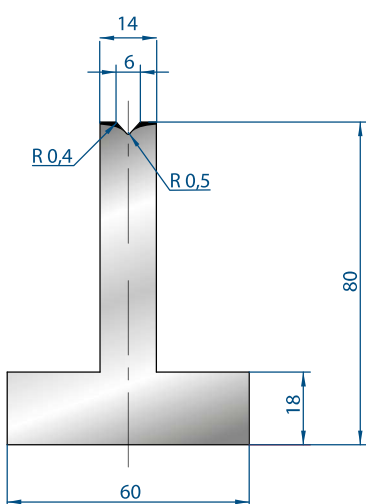

### 3086

835 mm	12,7 kg	<b>Mat = C45</b>
415 mm	6,3 kg	
805 mm	12,2 kg	<b>Max T/m = 100</b>
FRAZ. / SECT.		<b>α = 85°</b>

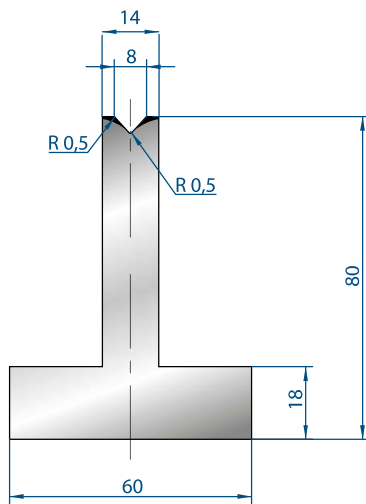

### 3087

835 mm	12,6 kg	<b>Mat = C45</b>
415 mm	6,3 kg	
805 mm	12,2 kg	<b>Max T/m = 100</b>
FRAZ. / SECT.		<b>α = 85°</b>

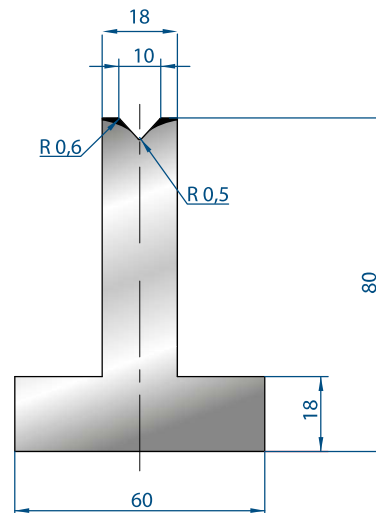

### 3088

835 mm	14,2 kg	<b>Mat = C45</b>
415 mm	7,0 kg	
805 mm	13,7 kg	<b>Max T/m = 100</b>
FRAZ. / SECT.		<b>α = 85°</b>

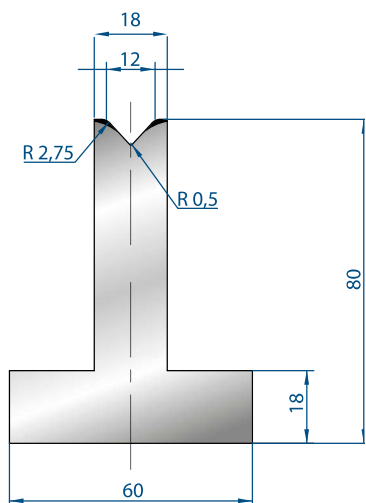

### 3089

835 mm	14,1 kg	<b>Mat = C45</b>
415 mm	7,0 kg	
805 mm	13,6 kg	<b>Max T/m = 100</b>
FRAZ. / SECT.		<b>α = 85°</b>

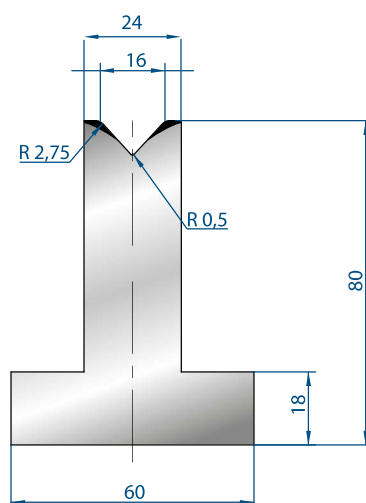

### 3090

835 mm	16,3 kg	<b>Mat = C45</b>
415 mm	8,1 kg	
805 mm	15,7 kg	<b>Max T/m = 100</b>
FRAZ. / SECT.		<b>α = 85°</b>

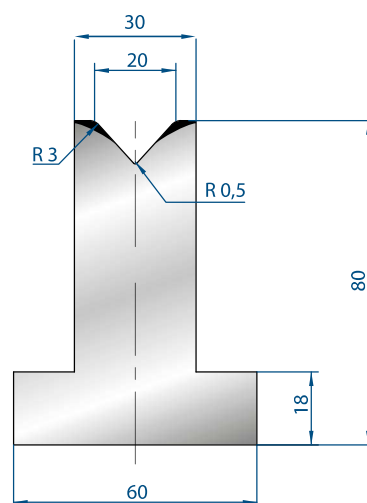

### 3091

835 mm	18,5 kg	<b>Mat = C45</b>
415 mm	9,2 kg	
805 mm	17,8 kg	<b>Max T/m = 100</b>
FRAZ. / SECT.		<b>α = 85°</b>

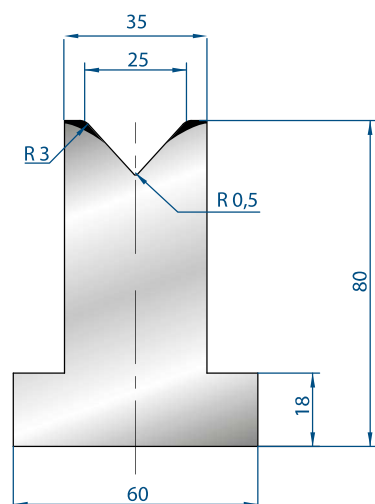

### 3092

835 mm	20,1 kg
415 mm	10,0 kg
805 mm	19,4 kg
FRAZ. / SECT.	

**Mat = C45**  
**Max T/m = 100**  
**α = 85°**



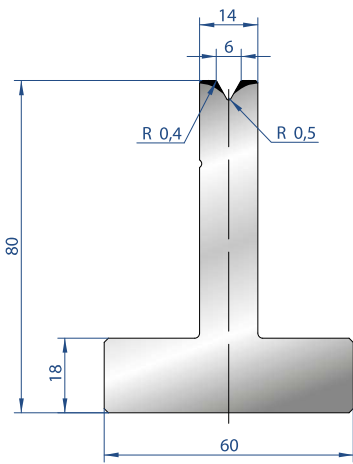

**3019**

835 mm	12,6 kg	<b>Mat = C45</b> <b>Max T/m = 60</b> <b>α = 60°</b>
415 mm	6,3 kg	
805 mm FRAZ. / SECT.	12,2 kg	

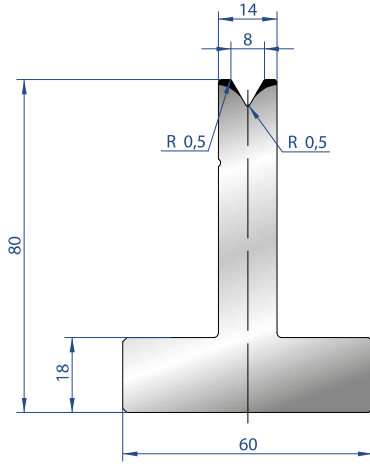

**3020**

835 mm	12,5 kg	<b>Mat = C45</b> <b>Max T/m = 60</b> <b>α = 60°</b>
415 mm	6,2 kg	
805 mm FRAZ. / SECT.	12,1 kg	

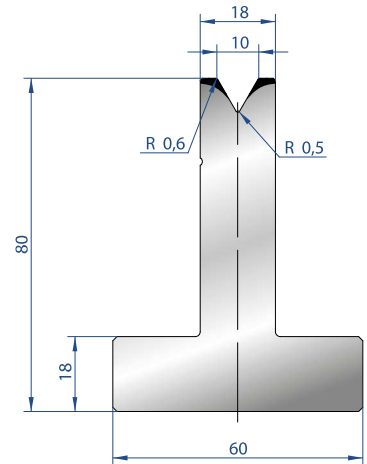

**3021**

835 mm	14,1 kg	<b>Mat = C45</b> <b>Max T/m = 60</b> <b>α = 60°</b>
415 mm	7,0 kg	
805 mm FRAZ. / SECT.	13,6 kg	

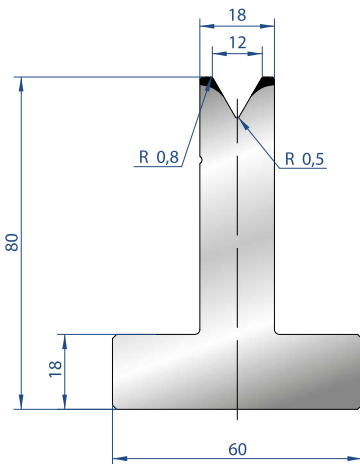

**3022**

835 mm	13,9 kg	<b>Mat = C45</b> <b>Max T/m = 60</b> <b>α = 60°</b>
415 mm	6,9 kg	
805 mm FRAZ. / SECT.	13,4 kg	

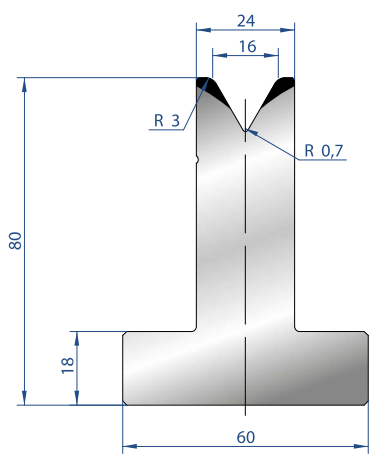

**3023**

835 mm	16,1 kg	<b>Mat = C45</b> <b>Max T/m = 75</b> <b>α = 60°</b>
415 mm	8,0 kg	
805 mm FRAZ. / SECT.	15,5 kg	

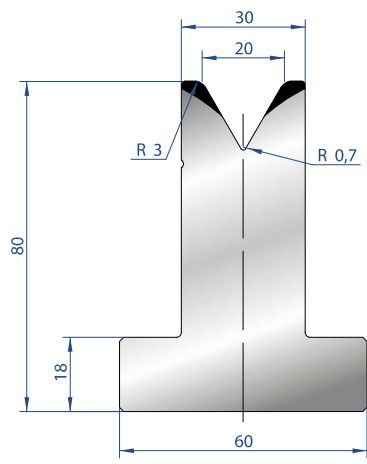

**3024**

835 mm	18,1 kg	<b>Mat = C45</b> <b>Max T/m = 70</b> <b>α = 60°</b>
415 mm	9,0 kg	
805 mm FRAZ. / SECT.	17,4 kg	



**3025**

835 mm	19,5 kg
415 mm	9,7 kg
805 mm FRAZ. / SECT.	18,8 kg

**Mat = C45**  
**Max T/m = 65**  
**α = 60°**

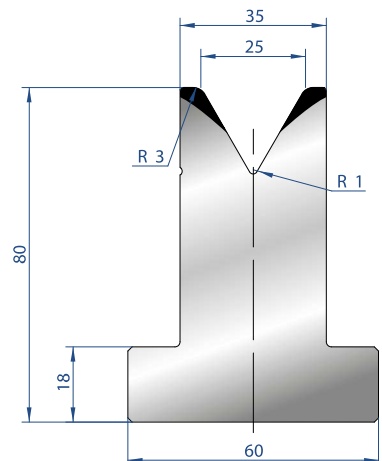

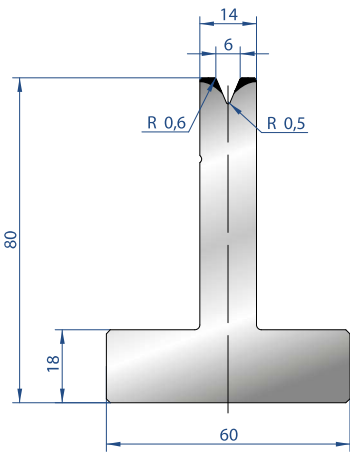

**3026**

835 mm	12,6 kg
415 mm	6,3 kg
805 mm	12,1 kg
FRAZ. / SECT.	

Mat = C45  
Max T/m = 50  
 $\alpha = 45^\circ$

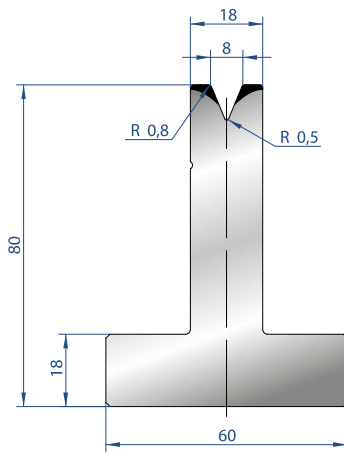

**3027**

835 mm	14,1 kg
415 mm	7,0 kg
805 mm	13,6 kg
FRAZ. / SECT.	

Mat = C45  
Max T/m = 50  
 $\alpha = 45^\circ$

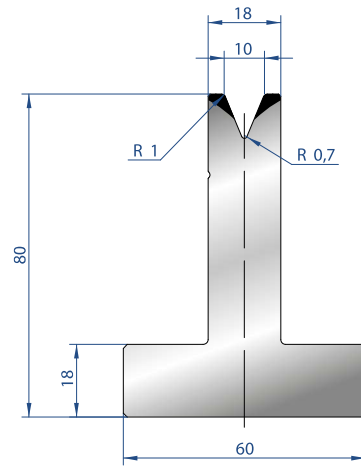

**3028**

835 mm	14,0 kg
415 mm	6,9 kg
805 mm	13,5 kg
FRAZ. / SECT.	

Mat = C45  
Max T/m = 50  
 $\alpha = 45^\circ$

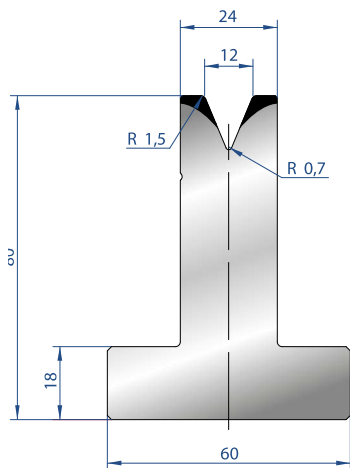

**3029**

835 mm	16,2 kg
415 mm	8,1 kg
805 mm	15,6 kg
FRAZ. / SECT.	

Mat = C45  
Max T/m = 50  
 $\alpha = 45^\circ$

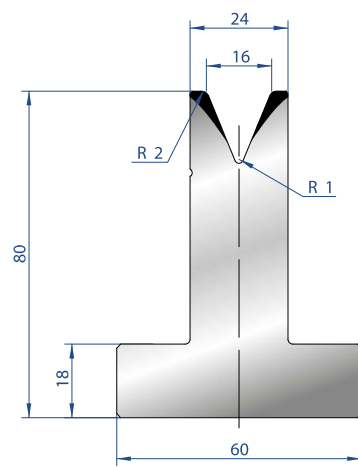

**3030**

835 mm	15,8 kg
415 mm	7,8 kg
805 mm	15,2 kg
FRAZ. / SECT.	

Mat = C45  
Max T/m = 50  
 $\alpha = 45^\circ$

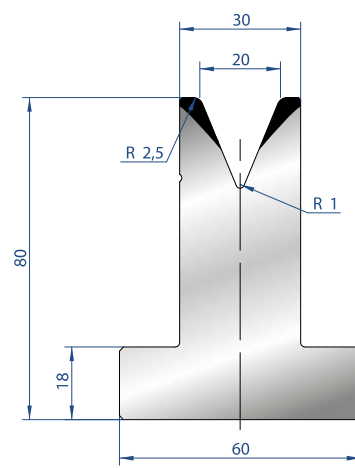

**3031**

835 mm	17,6 kg
415 mm	8,8 kg
805 mm	17,0 kg
FRAZ. / SECT.	

Mat = C45  
Max T/m = 50  
 $\alpha = 45^\circ$

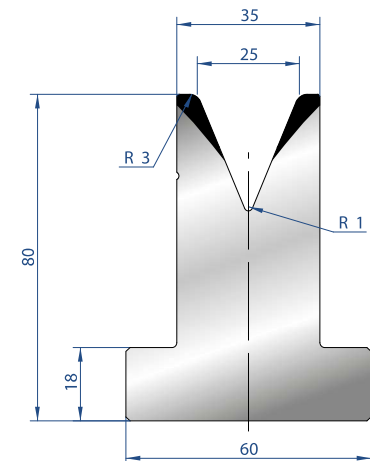

**3032**

835 mm	18,8 kg
415 mm	9,3 kg
805 mm	18,1 kg
FRAZ. / SECT.	

Mat = C45  
Max T/m = 50  
 $\alpha = 45^\circ$



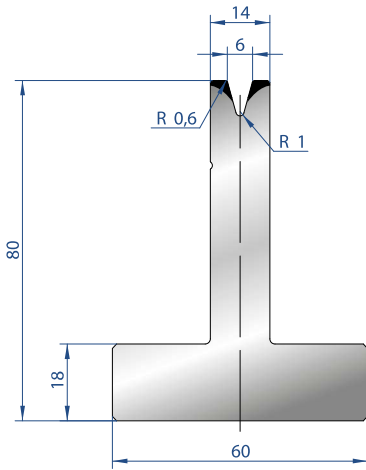

### 3042

835 mm	12,5 kg	<b>Mat</b> = C45
415 mm	6,2 kg	
805 mm	12,1 kg	<b>Max T/m</b> = 35
FRAZ. / SECT.		$\alpha = 30^\circ$

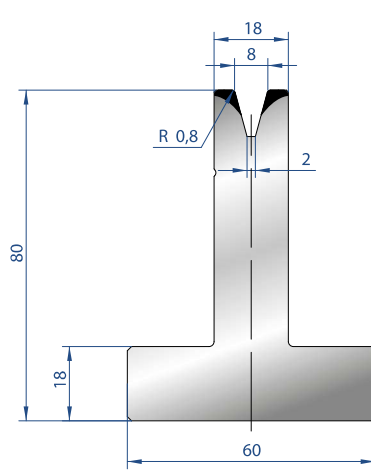

### 3043

835 mm	14,0 kg	<b>Mat</b> = C45
415 mm	6,9 kg	
805 mm	13,5 kg	<b>Max T/m</b> = 40
FRAZ. / SECT.		$\alpha = 30^\circ$

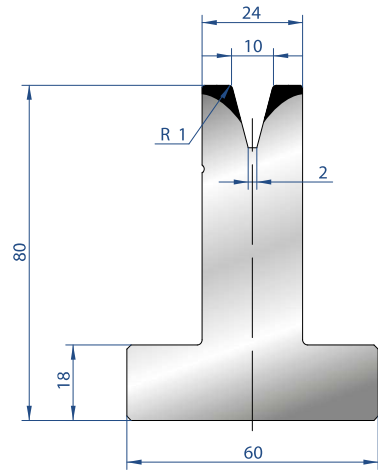

### 3044

835 mm	16,2 kg	<b>Mat</b> = C45
415 mm	8,0 kg	
805 mm	15,6 kg	<b>Max T/m</b> = 50
FRAZ. / SECT.		$\alpha = 30^\circ$

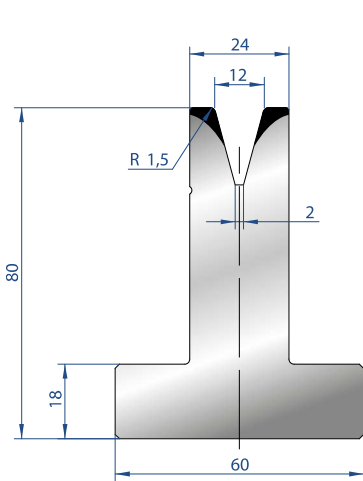

### 3045

835 mm	15,9 kg	<b>Mat</b> = C45
415 mm	7,9 kg	
805 mm	13,4 kg	<b>Max T/m</b> = 50
FRAZ. / SECT.		$\alpha = 30^\circ$

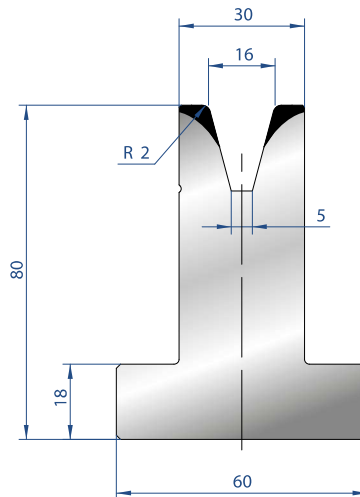

### 3046

835 mm	17,8 kg	<b>Mat</b> = C45
415 mm	8,8 kg	
805 mm	17,2 kg	<b>Max T/m</b> = 50
FRAZ. / SECT.		$\alpha = 30^\circ$

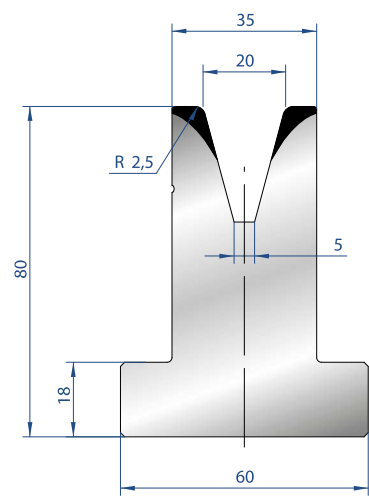

### 3047

835 mm	18,9 kg	<b>Mat</b> = C45
415 mm	9,4 kg	
805 mm	18,3 kg	<b>Max T/m</b> = 55
FRAZ. / SECT.		$\alpha = 30^\circ$



### 3048

835 mm	19,6 kg
415 mm	9,7 kg
805 mm	18,9 kg
FRAZ. / SECT.	

**Mat** = C45  
**Max T/m** = 55  
 $\alpha = 30^\circ$

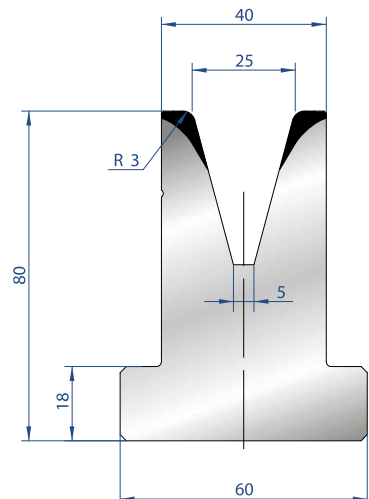

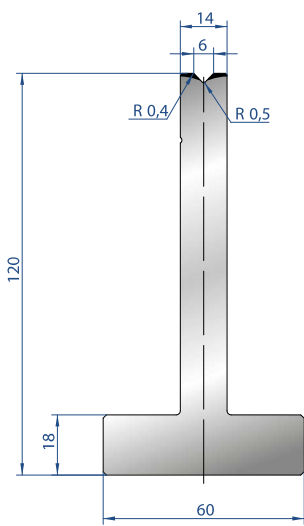

### 3083

835 mm	16,3 kg
415 mm	8,1 kg
805 mm	15,7 kg
FRAZ. / SECT.	

Mat = C45  
Max T/m = 100  
 $\alpha = 88^\circ$

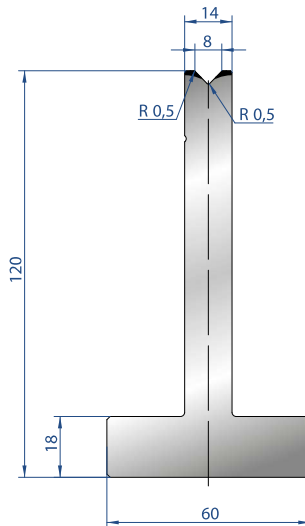

### 3084

835 mm	16,3 kg
415 mm	8,1 kg
805 mm	15,7 kg
FRAZ. / SECT.	

Mat = C45  
Max T/m = 100  
 $\alpha = 88^\circ$

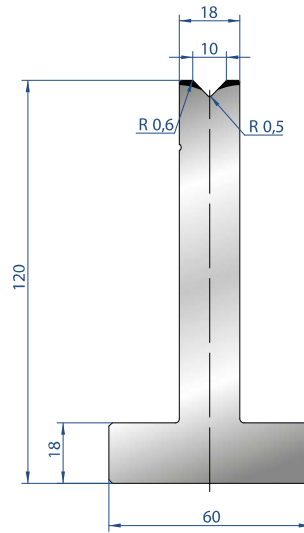

### 3085

835 mm	18,9 kg
415 mm	9,4 kg
805 mm	18,2 kg
FRAZ. / SECT.	

Mat = C45  
Max T/m = 100  
 $\alpha = 88^\circ$

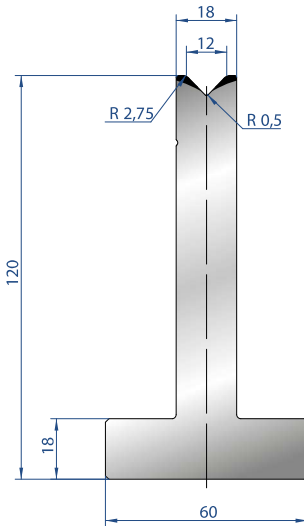

### 3055

835 mm	18,8 kg
415 mm	9,3 kg
805 mm	18,1 kg
FRAZ. / SECT.	

Mat = C45  
Max T/m = 100  
 $\alpha = 88^\circ$

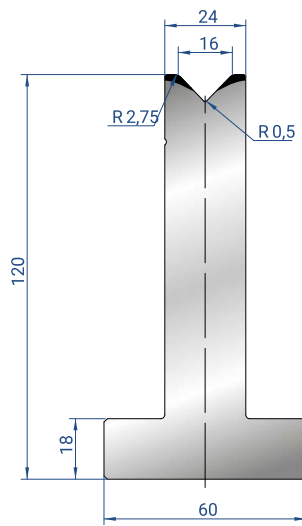

### 3056

835 mm	22,6 kg
415 mm	11,2 kg
805 mm	21,8 kg
FRAZ. / SECT.	

Mat = C45  
Max T/m = 100  
 $\alpha = 88^\circ$

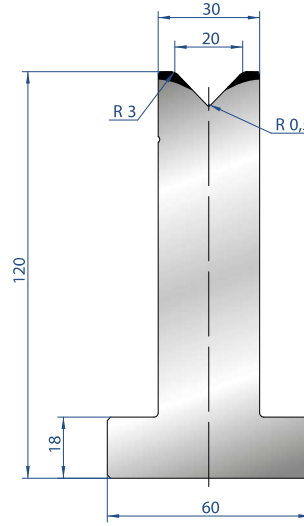

### 3057

835 mm	26,4 kg
415 mm	13,1 kg
805 mm	25,4 kg
FRAZ. / SECT.	

Mat = C45  
Max T/m = 100  
 $\alpha = 88^\circ$

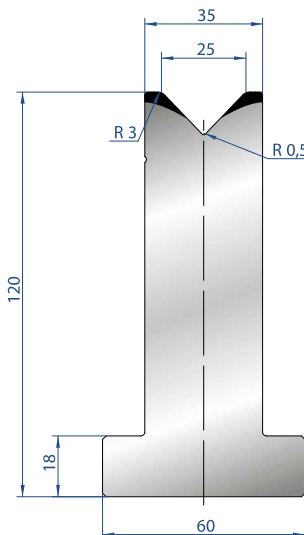

### 3058

835 mm	29,3 kg
415 mm	14,6 kg
805 mm	28,3 kg
FRAZ. / SECT.	

Mat = C45  
Max T/m = 100  
 $\alpha = 88^\circ$



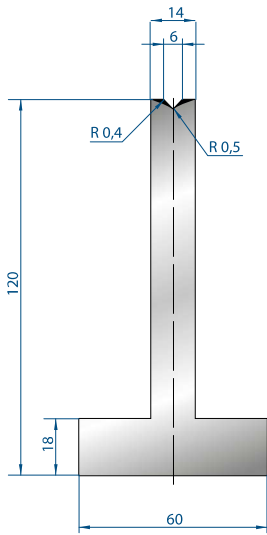

### 3093

835 mm	16,3 kg	<b>Mat = C45</b> <b>Max T/m = 100</b> <b>α = 85°</b>
415 mm	8,1 kg	
805 mm	15,7 kg	
FRAZ. / SECT.		

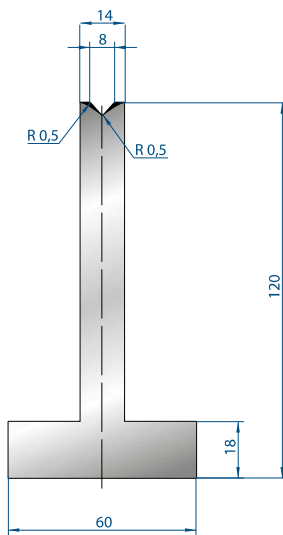

### 3094

835 mm	16,3 kg	<b>Mat = C45</b> <b>Max T/m = 100</b> <b>α = 85°</b>
415 mm	8,1 kg	
805 mm	15,7 kg	
FRAZ. / SECT.		

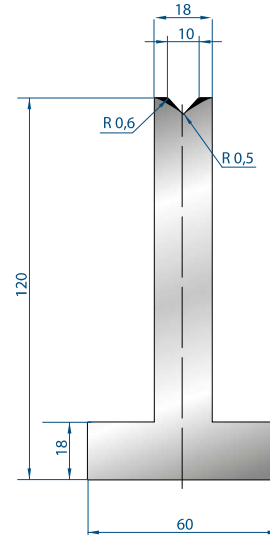

### 3095

835 mm	18,9 kg	<b>Mat = C45</b> <b>Max T/m = 100</b> <b>α = 85°</b>
415 mm	9,4 kg	
805 mm	18,2 kg	
FRAZ. / SECT.		

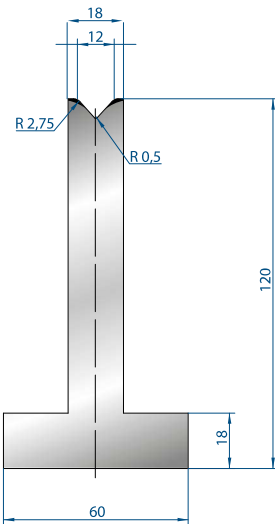

### 3096

835 mm	18,8 kg	<b>Mat = C45</b> <b>Max T/m = 100</b> <b>α = 85°</b>
415 mm	9,3 kg	
805 mm	18,1 kg	
FRAZ. / SECT.		

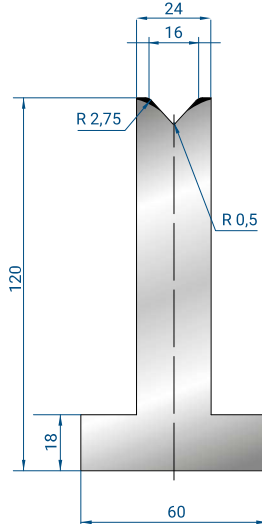

### 3097

835 mm	22,6 kg	<b>Mat = C45</b> <b>Max T/m = 100</b> <b>α = 85°</b>
415 mm	11,2 kg	
805 mm	21,8 kg	
FRAZ. / SECT.		

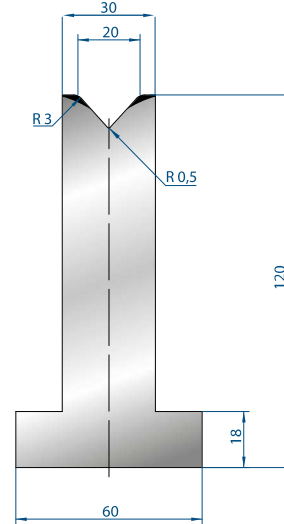

### 3098

835 mm	26,3 kg	<b>Mat = C45</b> <b>Max T/m = 100</b> <b>α = 85°</b>
415 mm	13,1 kg	
805 mm	25,4 kg	
FRAZ. / SECT.		



### 3099

835 mm	29,3 kg
415 mm	14,6 kg
805 mm	28,3 kg
FRAZ. / SECT.	

**Mat = C45**  
**Max T/m = 100**  
**α = 85°**

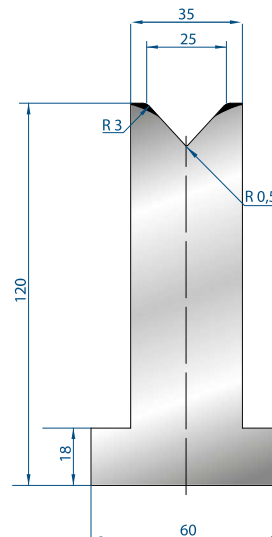

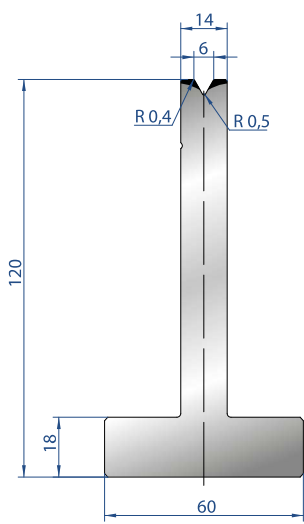

**3059**

835 mm	16,3 kg
415 mm	8,1 kg
805 mm	15,7 kg
FRAZ. / SECT.	

Mat = C45  
Max T/m = 60  
 $\alpha = 60^\circ$

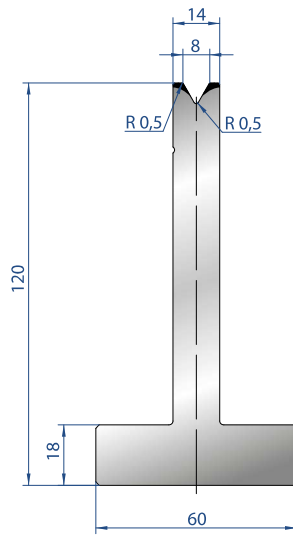

**3060**

835 mm	16,2 kg
415 mm	8,1 kg
805 mm	15,6 kg
FRAZ. / SECT.	

Mat = C45  
Max T/m = 60  
 $\alpha = 60^\circ$

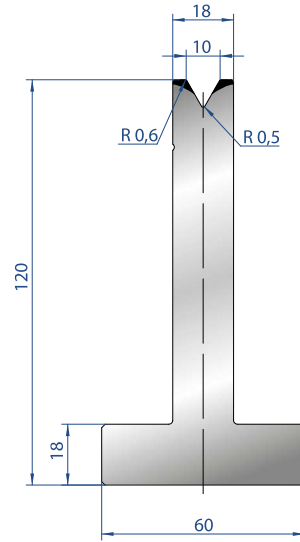

**3061**

835 mm	18,8 kg
415 mm	9,3 kg
805 mm	18,1 kg
FRAZ. / SECT.	

Mat = C45  
Max T/m = 60  
 $\alpha = 60^\circ$

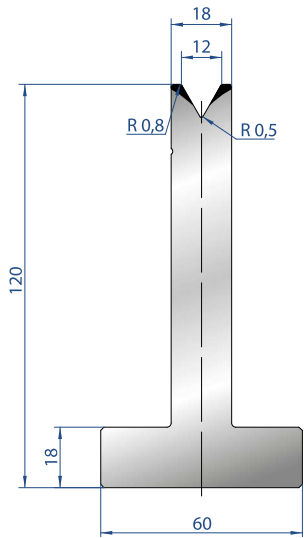

**3062**

835 mm	18,7 kg
415 mm	9,3 kg
805 mm	18,0 kg
FRAZ. / SECT.	

Mat = C45  
Max T/m = 60  
 $\alpha = 60^\circ$

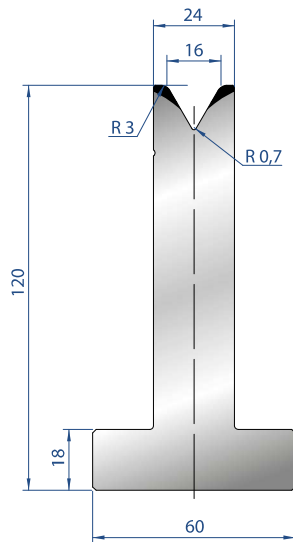

**3063**

835 mm	22,3 kg
415 mm	11,1 kg
805 mm	21,5 kg
FRAZ. / SECT.	

Mat = C45  
Max T/m = 75  
 $\alpha = 60^\circ$

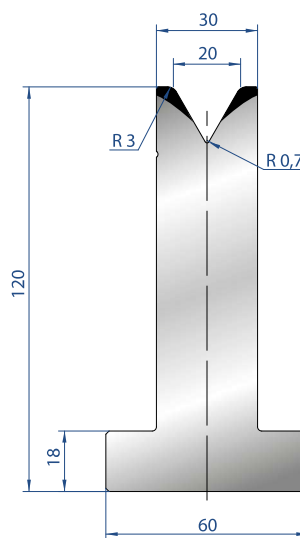

**3064**

835 mm	25,9 kg
415 mm	12,9 kg
805 mm	25,0 kg
FRAZ. / SECT.	

Mat = C45  
Max T/m = 70  
 $\alpha = 60^\circ$

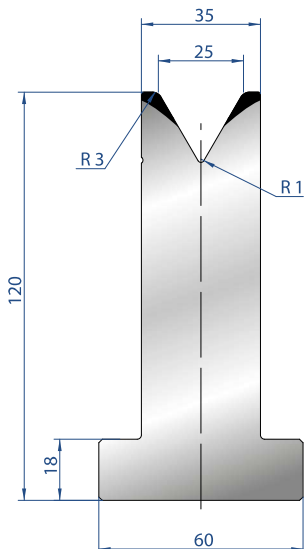

**3065**

835 mm	28,6 kg
415 mm	14,2 kg
805 mm	27,6 kg
FRAZ. / SECT.	

Mat = C45  
Max T/m = 65  
 $\alpha = 60^\circ$



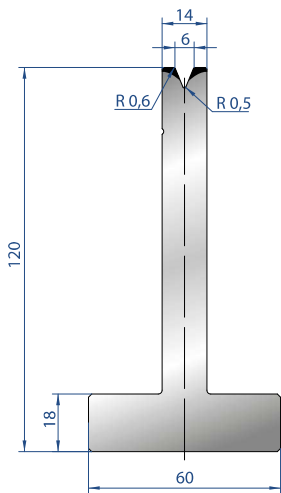

### 3066

835 mm	16,2 kg
415 mm	8,1 kg
805 mm	15,7 kg
FRAZ. / SECT.	

Mat = C45  
Max T/m = 50  
 $\alpha = 45^\circ$

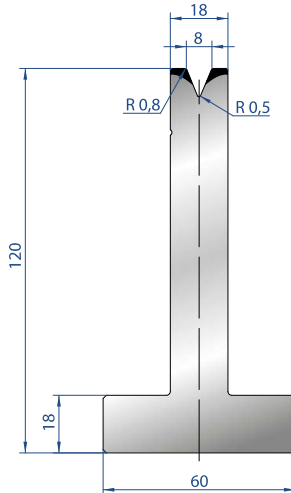

### 3067

835 mm	18,8 kg
415 mm	9,3 kg
805 mm	18,1 kg
FRAZ. / SECT.	

Mat = C45  
Max T/m = 50  
 $\alpha = 45^\circ$

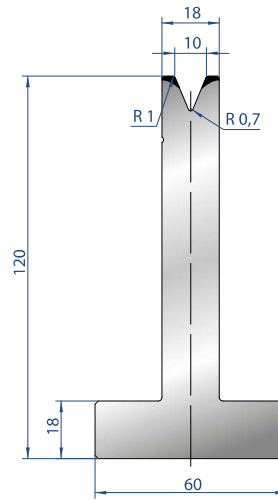

### 3068

835 mm	18,7 kg
415 mm	9,3 kg
805 mm	18,0 kg
FRAZ. / SECT.	

Mat = C45  
Max T/m = 50  
 $\alpha = 45^\circ$

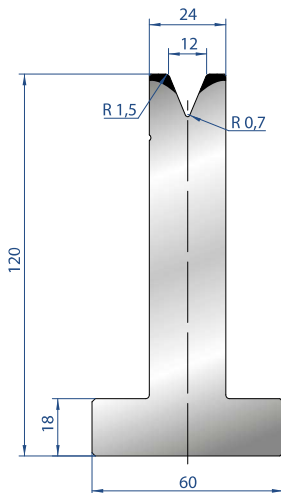

### 3069

835 mm	22,5 kg
415 mm	11,2 kg
805 mm	21,7 kg
FRAZ. / SECT.	

Mat = C45  
Max T/m = 50  
 $\alpha = 45^\circ$

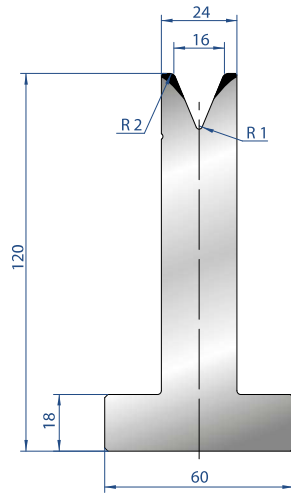

### 3070

835 mm	22,1 kg
415 mm	11,0 kg
805 mm	21,3 kg
FRAZ. / SECT.	

Mat = C45  
Max T/m = 50  
 $\alpha = 45^\circ$

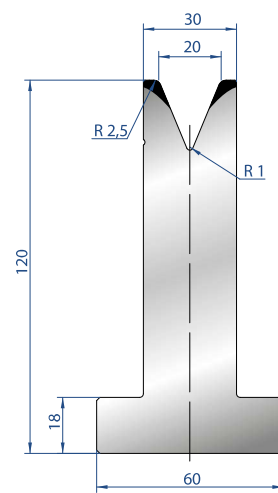

### 3071

835 mm	25,5 kg
415 mm	12,7 kg
805 mm	24,6 kg
FRAZ. / SECT.	

Mat = C45  
Max T/m = 50  
 $\alpha = 45^\circ$



### 3072

835 mm	27,9 kg
415 mm	13,9 kg
805 mm	26,9 kg
FRAZ. / SECT.	

Mat = C45  
Max T/m = 50  
 $\alpha = 45^\circ$

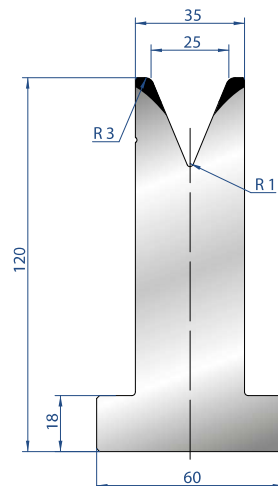

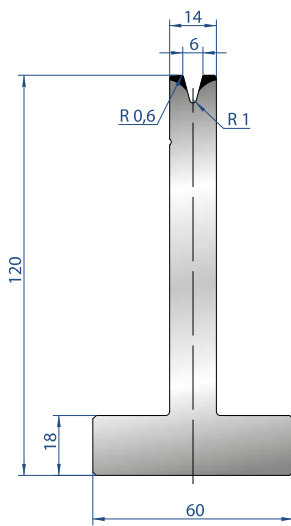

**3073**

835 mm	16,2 kg	<b>Mat = C45</b> <b>Max T/m = 35</b> <b>α = 30°</b>
415 mm	8,0 kg	
805 mm	15,6 kg	
FRAZ. / SECT.		

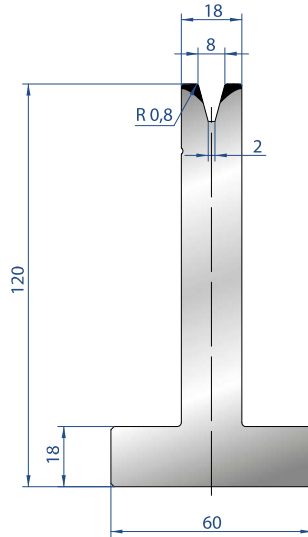

**3074**

835 mm	18,7 kg	<b>Mat = C45</b> <b>Max T/m = 40</b> <b>α = 30°</b>
415 mm	9,3 kg	
805 mm	18,0 kg	
FRAZ. / SECT.		

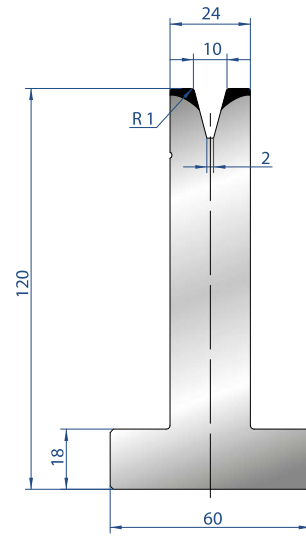

**3075**

835 mm	22,5 kg	<b>Mat = C45</b> <b>Max T/m = 50</b> <b>α = 30°</b>
415 mm	11,2 kg	
805 mm	21,7 kg	
FRAZ. / SECT.		

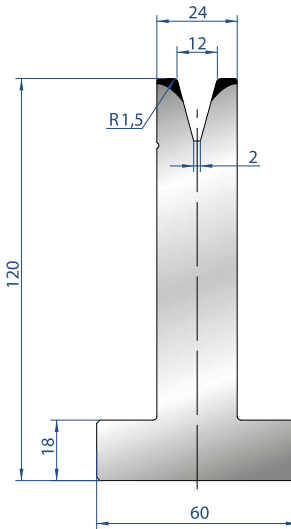

**3076**

835 mm	22,2 kg	<b>Mat = C45</b> <b>Max T/m = 50</b> <b>α = 30°</b>
415 mm	11,0 kg	
805 mm	21,4 kg	
FRAZ. / SECT.		

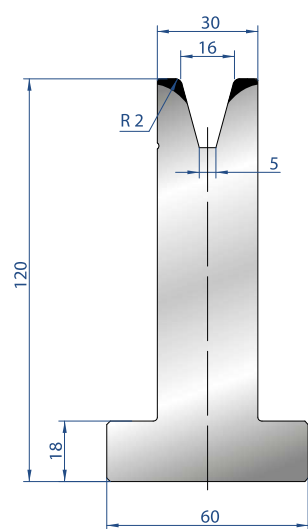

**3077**

835 mm	25,6 kg	<b>Mat = C45</b> <b>Max T/m = 50</b> <b>α = 30°</b>
415 mm	12,7 kg	
805 mm	24,7 kg	
FRAZ. / SECT.		

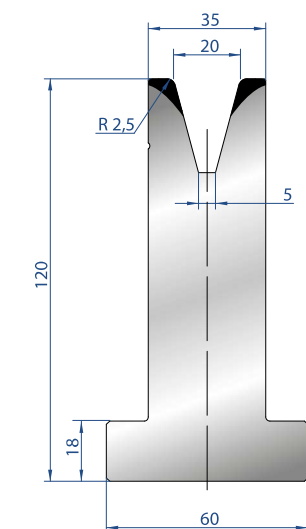

**3078**

835 mm	28,1 kg	<b>Mat = C45</b> <b>Max T/m = 55</b> <b>α = 30°</b>
415 mm	14,0 kg	
805 mm	27,1 kg	
FRAZ. / SECT.		

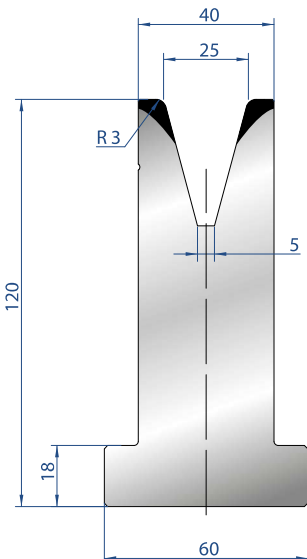

**3079**

835 mm	30,1 kg
415 mm	14,9 kg
805 mm	29,0 kg
FRAZ. / SECT.	

**Mat = C45**  
**Max T/m = 50**  
**α = 30°**



# SUPPORTO PER INSERTI MATRICE DIE INSERTS HOLDER

POLIURETANO  
POLYURETHAN

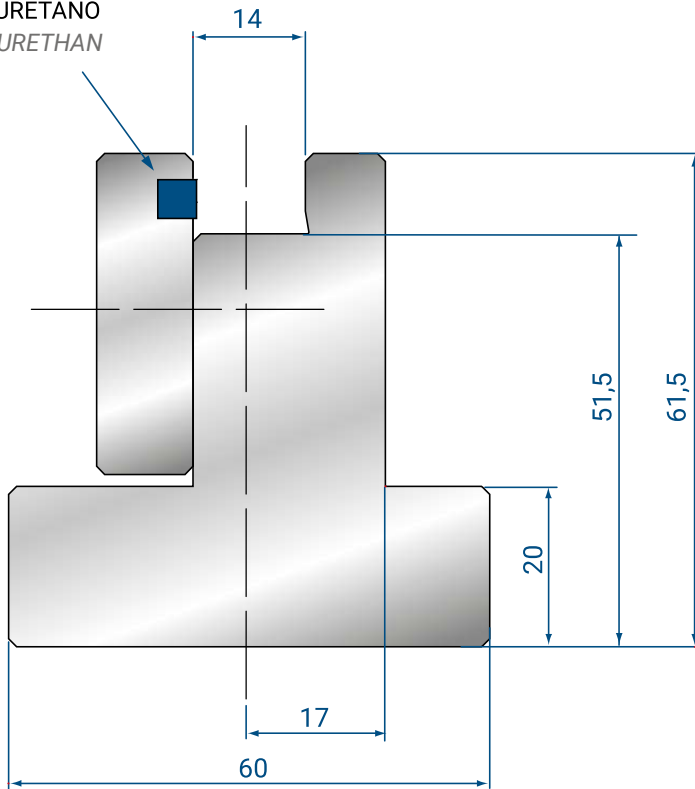

**3173**

835 mm	16,4 kg
415 mm	8,1 kg

ESEMPIO DI MONTAGGIO  
ASSEMBLY EXAMPLE

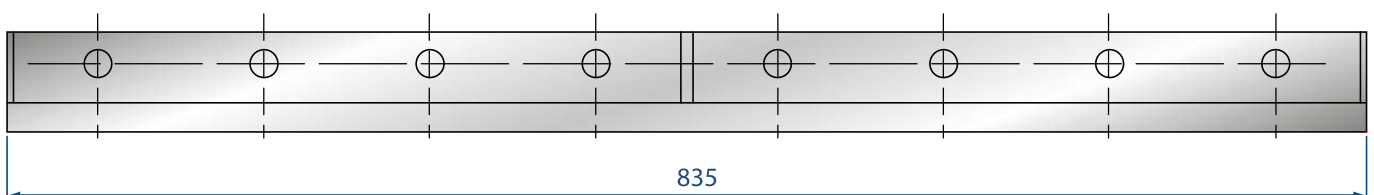
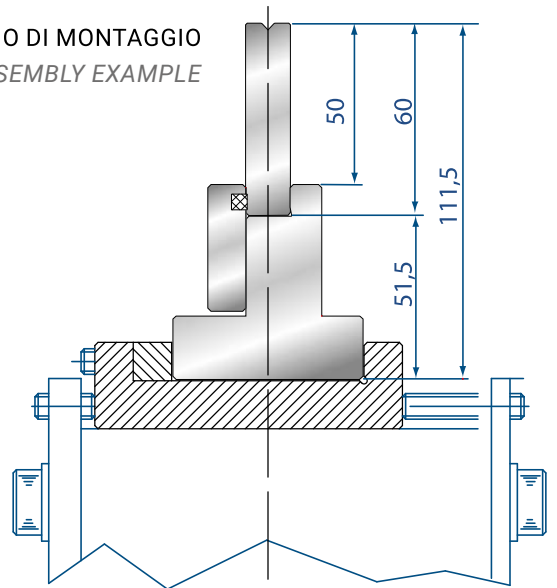



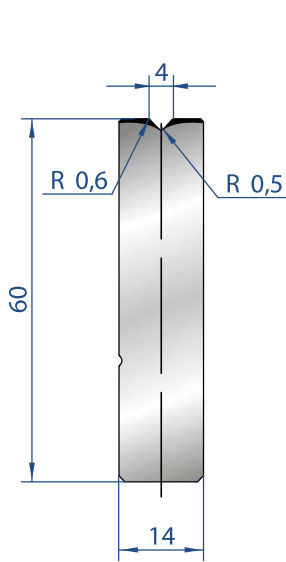

**3158**

**Mat = C45**  
**Max T/m = 100**  
 **$\alpha = 88^\circ$**

835 mm	5,5 kg
415 mm	2,7 kg
805 mm	5,3 kg
FRAZ. / SECT.	

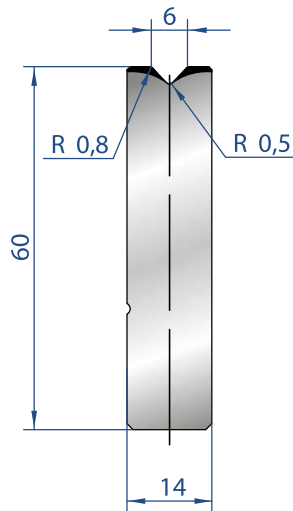

**3159**

**Mat = C45**  
**Max T/m = 100**  
 **$\alpha = 88^\circ$**

835 mm	5,4 kg
415 mm	2,7 kg
805 mm	5,2 kg
FRAZ. / SECT.	

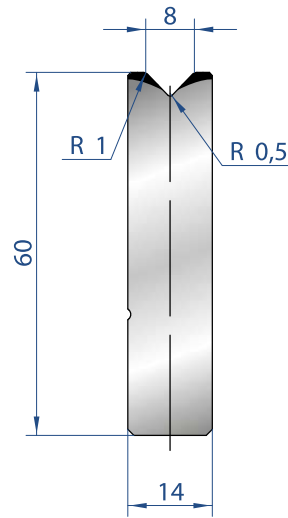

**3160**

**Mat = C45**  
**Max T/m = 100**  
 **$\alpha = 88^\circ$**

835 mm	5,4 kg
415 mm	2,7 kg
805 mm	5,2 kg
FRAZ. / SECT.	

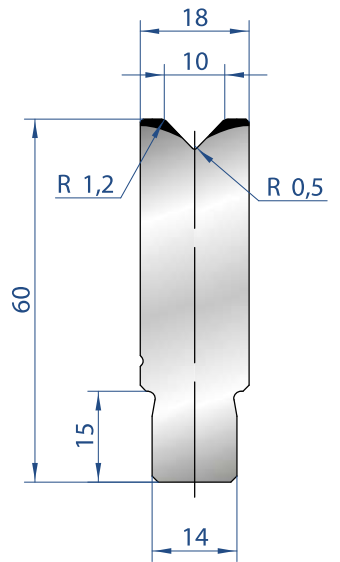

**3161**

**Mat = C45**  
**Max T/m = 100**  
 **$\alpha = 88^\circ$**

835 mm	6,5 kg
415 mm	3,2 kg
805 mm	6,3 kg
FRAZ. / SECT.	

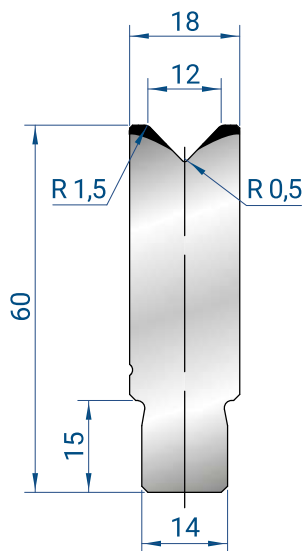

**3162**

**Mat = C45**  
**Max T/m = 100**  
 **$\alpha = 88^\circ$**

835 mm	6,4 kg
415 mm	3,2 kg
805 mm	6,2 kg
FRAZ. / SECT.	

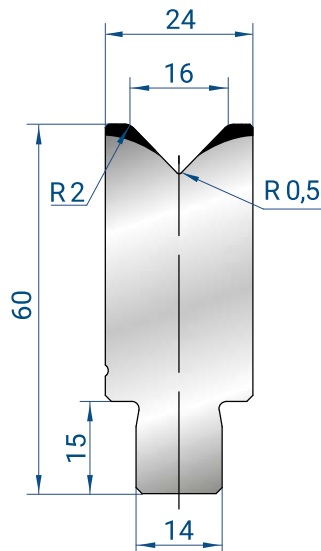

**3163**

**Mat = C45**  
**Max T/m = 100**  
 **$\alpha = 88^\circ$**

835 mm	8,0 kg
415 mm	4,0 kg
805 mm	7,7 kg
FRAZ. / SECT.	

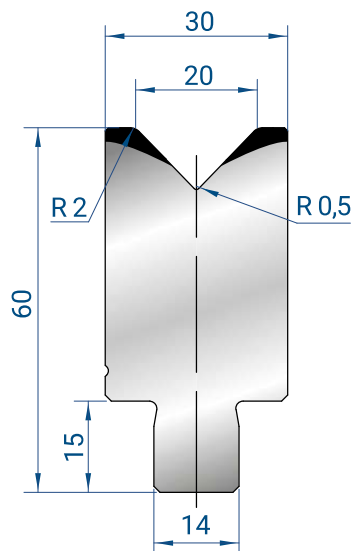

**3164**

**Mat = C45**  
**Max T/m = 100**  
 **$\alpha = 88^\circ$**

835 mm	9,5 kg
415 mm	4,7 kg
805 mm	9,2 kg
FRAZ. / SECT.	

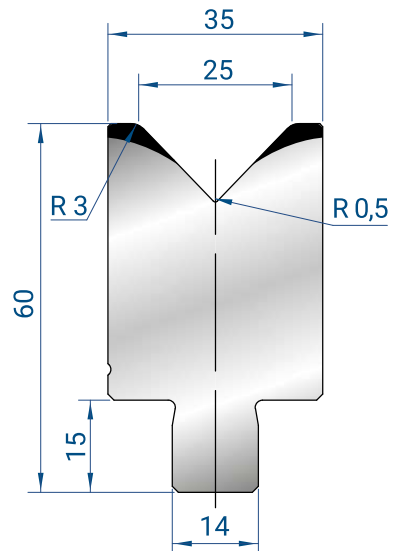

**3165**

**Mat = C45**  
**Max T/m = 100**  
 **$\alpha = 88^\circ$**

835 mm	10,6 kg
415 mm	5,3 kg
805 mm	10,2 kg
FRAZ. / SECT.	

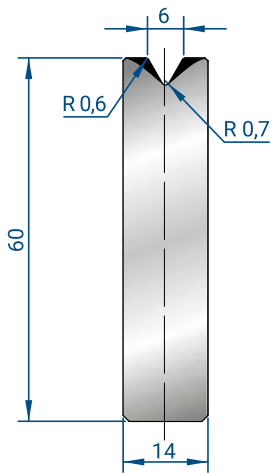

**3193**

Mat = C45  
Max T/m = 60  
 $\alpha = 60^\circ$

835 mm	5,4 kg
415 mm	2,7 kg
805 mm	5,2 kg
FRAZ. / SECT.	

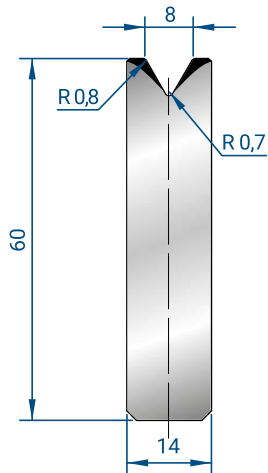

**3194**

Mat = C45  
Max T/m = 60  
 $\alpha = 60^\circ$

835 mm	5,3 kg
415 mm	2,6 kg
805 mm	5,1 kg
FRAZ. / SECT.	

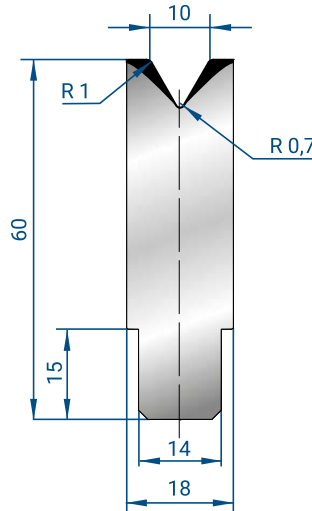

**3195**

Mat = C45  
Max T/m = 60  
 $\alpha = 60^\circ$

835 mm	6,4 kg
415 mm	3,2 kg
805 mm	6,1 kg
FRAZ. / SECT.	

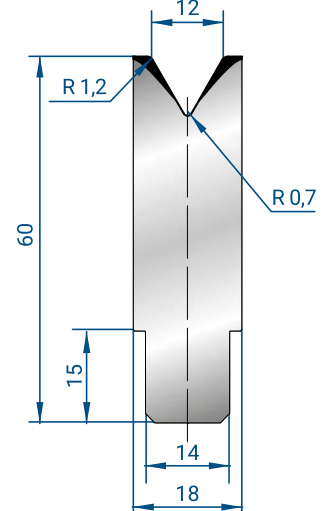

**3196**

Mat = C45  
Max T/m = 60  
 $\alpha = 60^\circ$

835 mm	6,3 kg
415 mm	3,1 kg
805 mm	6,0 kg
FRAZ. / SECT.	

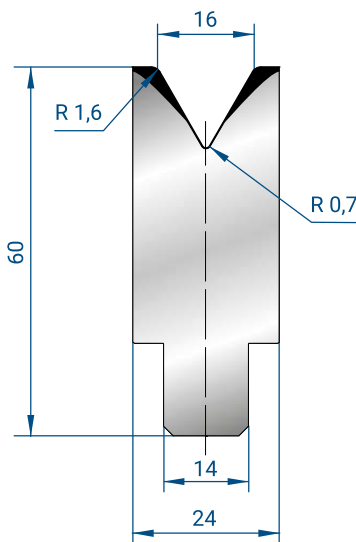

**3197**

Mat = C45  
Max T/m = 60  
 $\alpha = 60^\circ$

835 mm	7,7 kg
415 mm	3,8 kg
805 mm	7,4 kg
FRAZ. / SECT.	

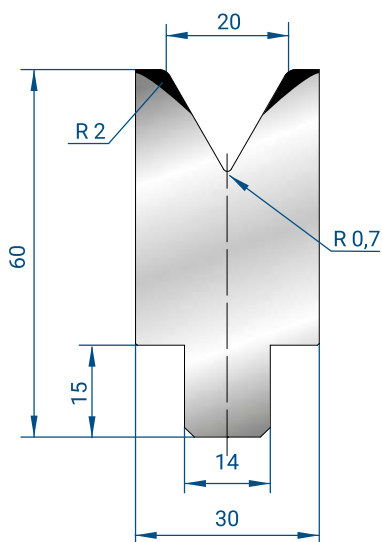

**3198**

Mat = C45  
Max T/m = 60  
 $\alpha = 60^\circ$

835 mm	9,1 kg
415 mm	4,5 kg
805 mm	8,7 kg
FRAZ. / SECT.	

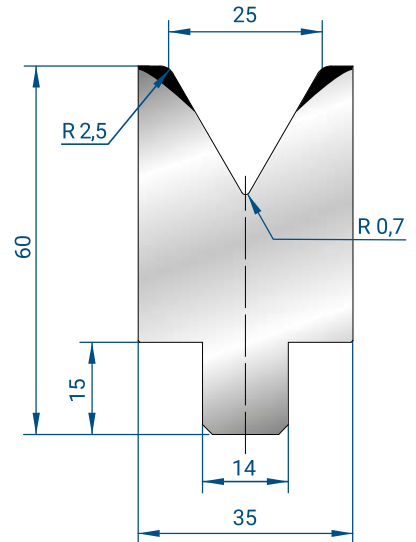

**3199**

Mat = C45  
Max T/m = 60  
 $\alpha = 60^\circ$

835 mm	9,9 kg
415 mm	4,9 kg
805 mm	9,5 kg
FRAZ. / SECT.	

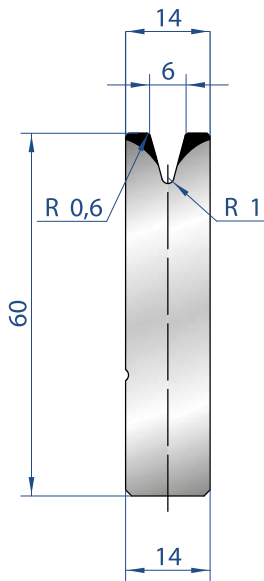

### 3166

Mat = C45  
Max T/m = 35  
 $\alpha = 30^\circ$

835 mm	5,3 kg
415 mm	2,6 kg
805 mm	5,1 kg
FRAZ. / SECT.	

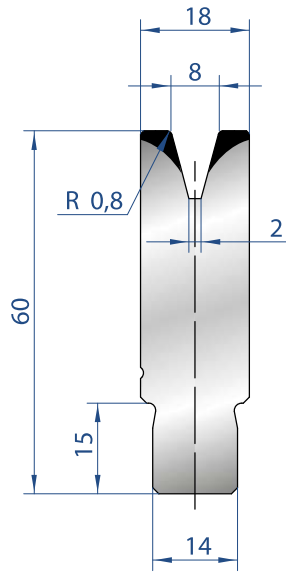

### 3167

Mat = C45  
Max T/m = 40  
 $\alpha = 30^\circ$

835 mm	6,3 kg
415 mm	3,1 kg
805 mm	6,1 kg
FRAZ. / SECT.	

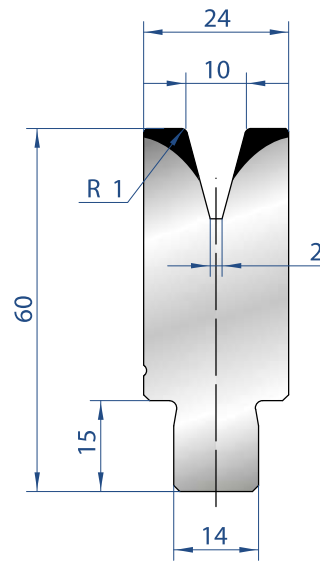

### 3168

Mat = C45  
Max T/m = 50  
 $\alpha = 30^\circ$

835 mm	7,8 kg
415 mm	3,9 kg
805 mm	7,5 kg
FRAZ. / SECT.	

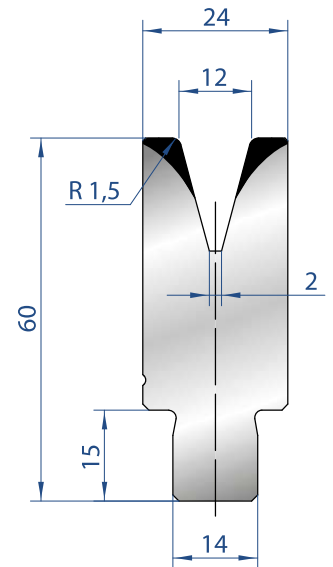

### 3169

Mat = C45  
Max T/m = 50  
 $\alpha = 30^\circ$

835 mm	7,6 kg
415 mm	3,8 kg
805 mm	7,3 kg
FRAZ. / SECT.	

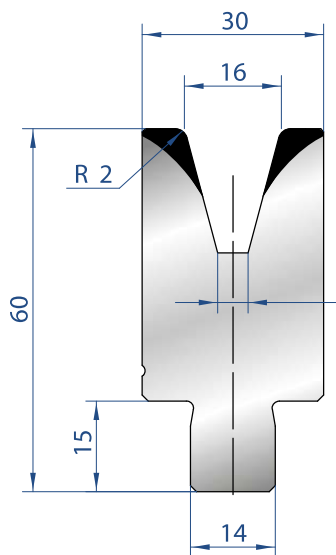

### 3170

Mat = C45  
Max T/m = 50  
 $\alpha = 30^\circ$

835 mm	8,7 kg
415 mm	4,4 kg
805 mm	8,5 kg
FRAZ. / SECT.	

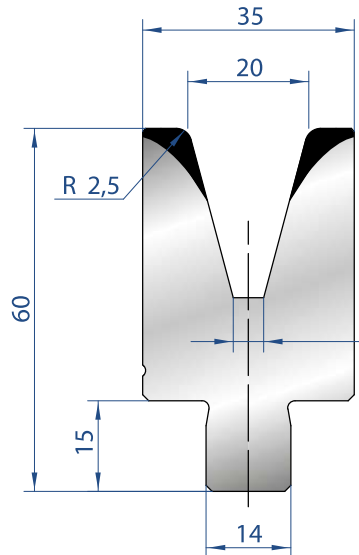

### 3171

Mat = C45  
Max T/m = 55  
 $\alpha = 30^\circ$

835 mm	9,4 kg
415 mm	4,7 kg
805 mm	9,0 kg
FRAZ. / SECT.	

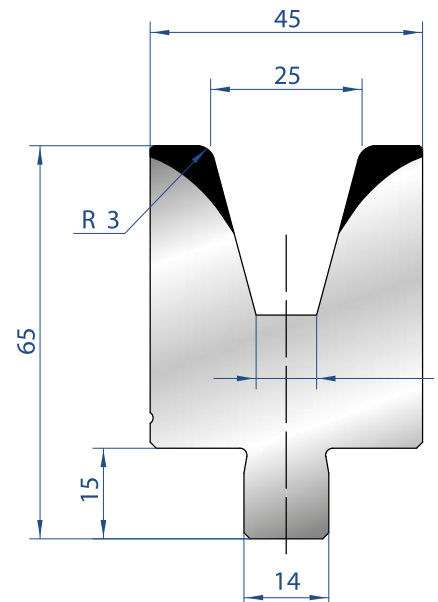

### 3172

Mat = C45  
Max T/m = 55  
 $\alpha = 30^\circ$

835 mm	12,9 kg
415 mm	6,4 kg
805 mm	12,4 kg
FRAZ. / SECT.	



 **EUROSTAMP TOOLING**  
the Italian excellence

**3040**      A 26°      V 12  
                 R 3            L 415  
                 H 135        100 T/m

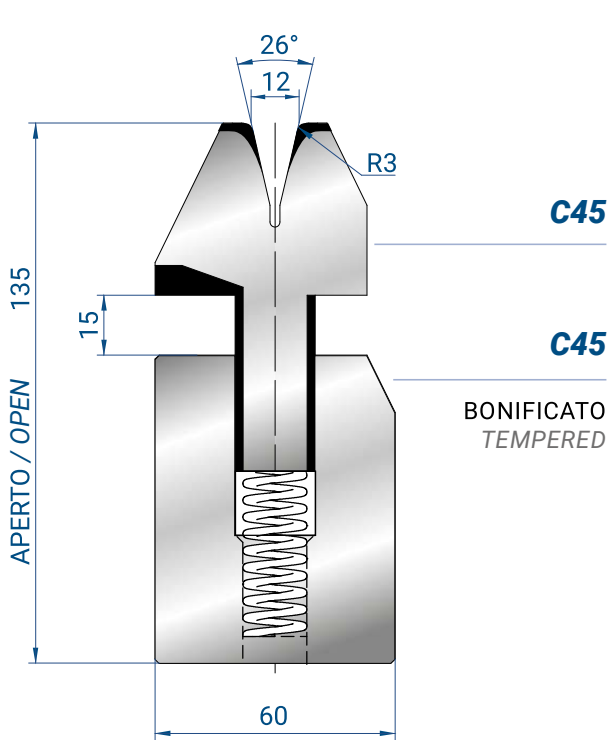

### 3040

835 mm	40,7 kg
415 mm	20,2 kg

Spessore /  
Sheet metal thickness =  
Min 1,5 mm - Max 3 mm  
Max T/m = 100

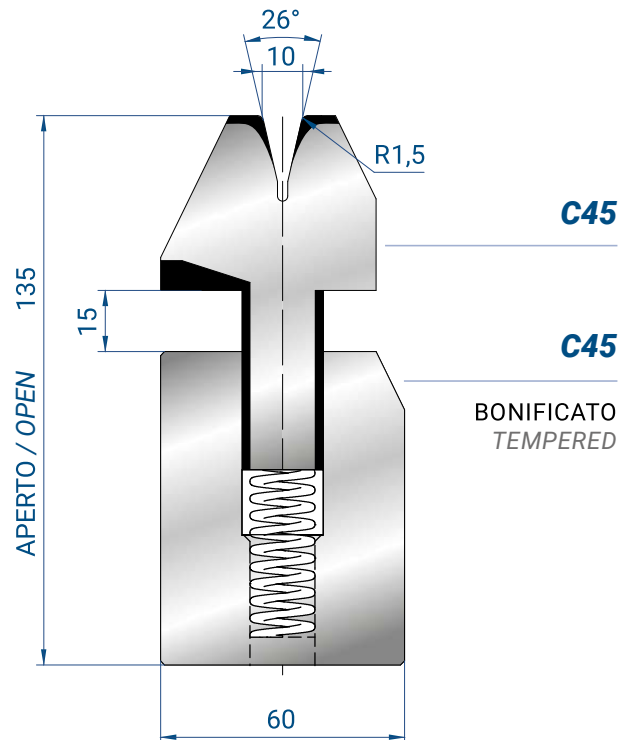

### 3038

835 mm	41,1 kg
415 mm	20,4 kg

Spessore /  
Sheet metal thickness =  
Min 1,5 mm - Max 2,5 mm  
Max T/m = 100

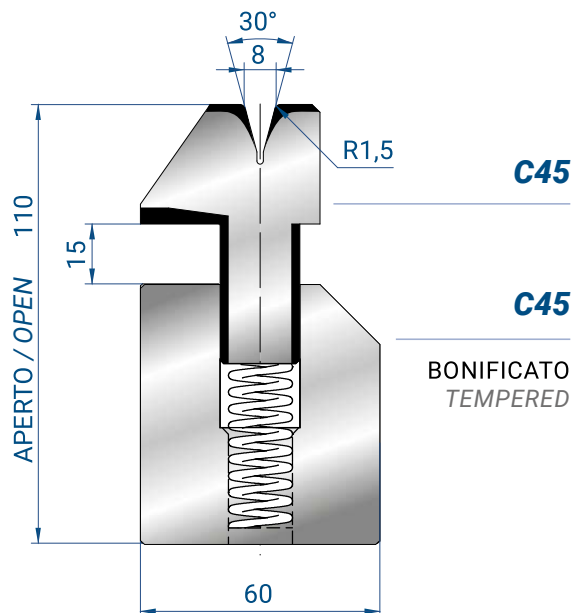

### 3041

835 mm	31,4 kg
415 mm	15,6 kg

Spessore /  
Sheet metal thickness = Max 1,5 mm  
Max T/m = 80

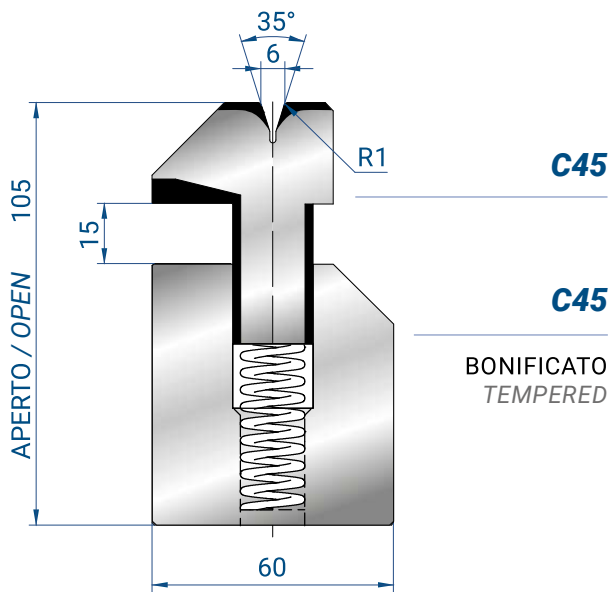

### 3039

835 mm	30,5 kg
415 mm	15,2 kg

Spessore /  
Sheet metal thickness = Max 1,0 mm  
Max T/m = 80

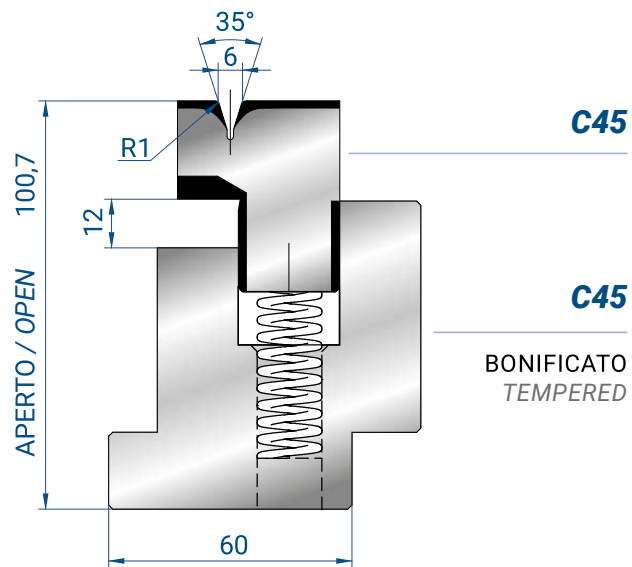

### 3037/6

835 mm	33,9 kg
415 mm	16,9 kg

Spessore /  
Sheet metal thickness = Max 1,0 mm  
Max T/m = 60

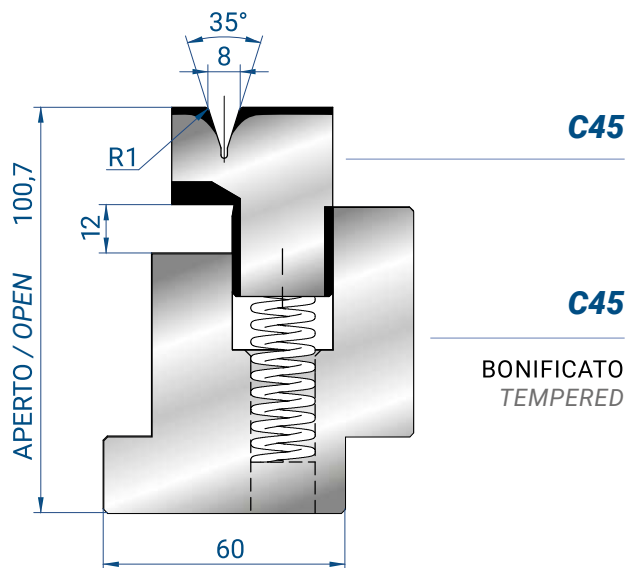

### 3037/8

835 mm	33,8 kg
415 mm	16,8 kg

Spessore /  
Sheet metal thickness = Max 1,2 mm  
Max T/m = 60

# TONNELLAGGI PER SCHIACCIATURA HEMMING POWER



Ferro normale R.45 Kg/mm<sup>q</sup> / Mild Steel R.45 Kg/mm<sup>q</sup>

S mm	A mm	Ton /M	2xS	Ton /M
0,6	3	9	1,2	23
0,8	3	12	1,6	32
1	3,5	15	2	40
1,25	3,5	17	2,5	50
1,5	4,6	22	3	63
2	5,5	30	4	80
2,5	6,5	55	5	90
3	8	70	6	100

Inox R.70 Kg/mm<sup>q</sup> / Stainless Steel R.70 Kg/mm<sup>q</sup>

S mm	A mm	Ton /M	2xS	Ton /M
0,6	3	15	1,2	35
0,8	3	20	1,6	50
1	3,5	25	2	60
1,25	3,5	26	2,5	80
1,5	4,6	38	3	95
2	5,5	50	4	130

## PIEGASCHIACCIA PNEUMATICI PNEUMATIC FLATTENING HEMMING TOOLS



**4313**

4,0 kg

**KIT PNEUMATICO  
PNEUMATIC KIT**

NECESSARIO PER  
INSTALLAZIONE SISTEMI  
PNEUMATICI  
MANDATORY FOR  
INSTALLATION OF  
PNEUMATIC SYSTEMS

	V	A	R	H aperto/open	Max T/M
<b>3038 PN</b>	10	26°	1,5	135	100
				835 mm	41,1 kg
				415 mm	20,4 kg
<b>3039 PN</b>	6	35°	1	105	80
				835 mm	30,5 kg
				415 mm	15,2 kg
<b>3040 PN</b>	12	26°	3	135	100
				835 mm	40,7 kg
				415 mm	20,2 kg
<b>3041 PN</b>	8	30°	1,5	110	80
				835 mm	31,4 kg
				415 mm	15,6 kg

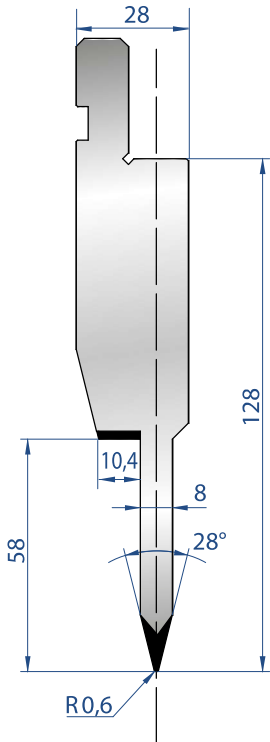

**1195**

**Mat = C45**  
bonificato /  
*tempered*  
**Max T/m = 80**

835 mm	17,4 kg
415 mm	8,7 kg
805 mm	16,0 kg
FRAZ. / SECT.	

**Spessore /  
Thickness**

Max 1,2 mm  
Ferro / *Mild steel*

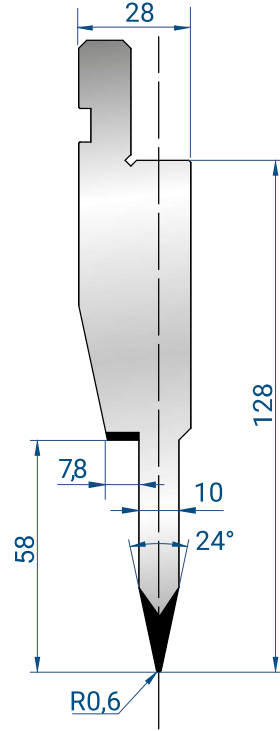

**1196**

**Mat = C45**  
bonificato /  
*tempered*  
**Max T/m = 80**

835 mm	17,5 kg
415 mm	8,7 kg
805 mm	16,1 kg
FRAZ. / SECT.	

**Spessore /  
Thickness**

Max 1,5 mm  
Ferro / *Mild steel*

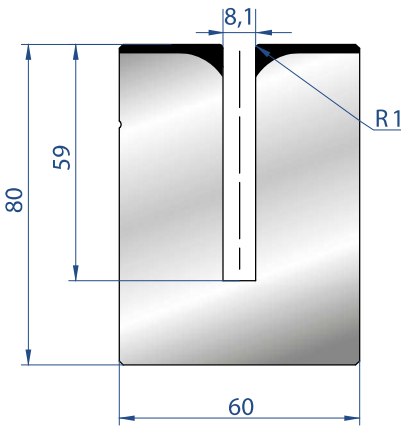

**3176**

**Mat = C45**  
bonificato /  
*tempered*  
**Max T/m = 50**

835 mm	28,2 kg
415 mm	14,0 kg
805 mm	27,2 kg
FRAZ. / SECT.	

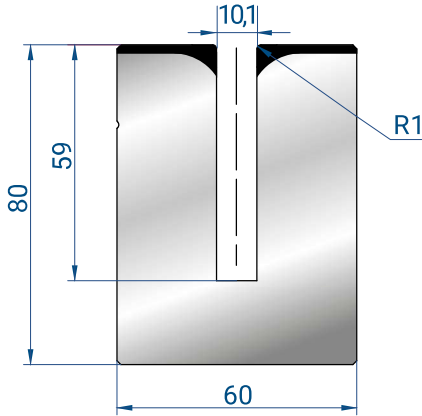

**3177**

**Mat = C45**  
bonificato /  
*tempered*  
**Max T/m = 50**

835 mm	27,5 kg
415 mm	13,7 kg
805 mm	26,5 kg
FRAZ. / SECT.	



# PIEGASCHIACCIA FLATTENING HEMMING TOOLS

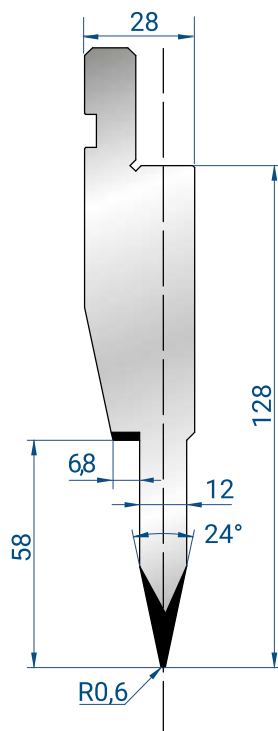

## 1197

**Mat** = C45  
bonificato /  
*tempered*  
**Max T/m** = 80

835 mm	18,0 kg
415 mm	8,9 kg
805 mm FRAZ. / SECT.	16,5 kg

**Spessore /  
Thickness**

Max 1,5 mm  
Ferro / *Mild steel*

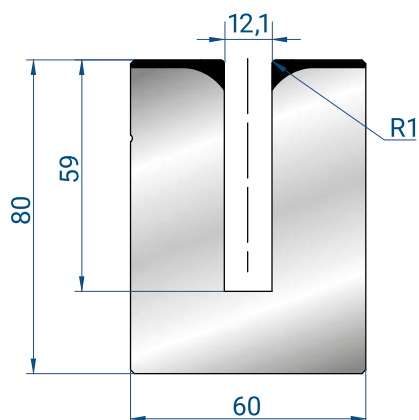

## 3178

**Mat** = C45  
bonificato /  
*tempered*  
**Max T/m** = 50

835 mm	26,7 kg
415 mm	13,3 kg
805 mm FRAZ. / SECT.	25,7 kg

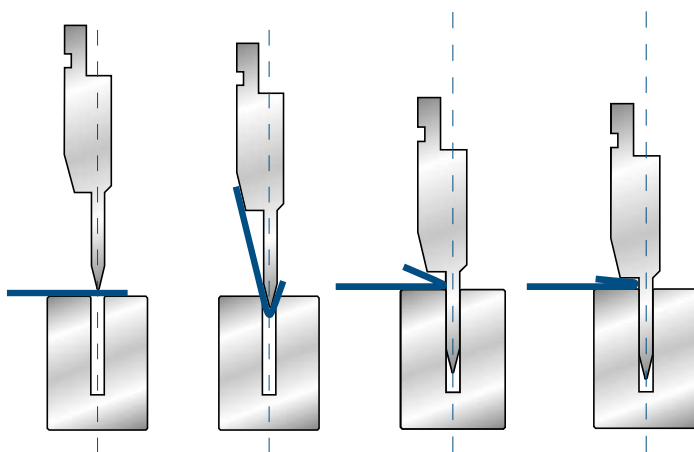

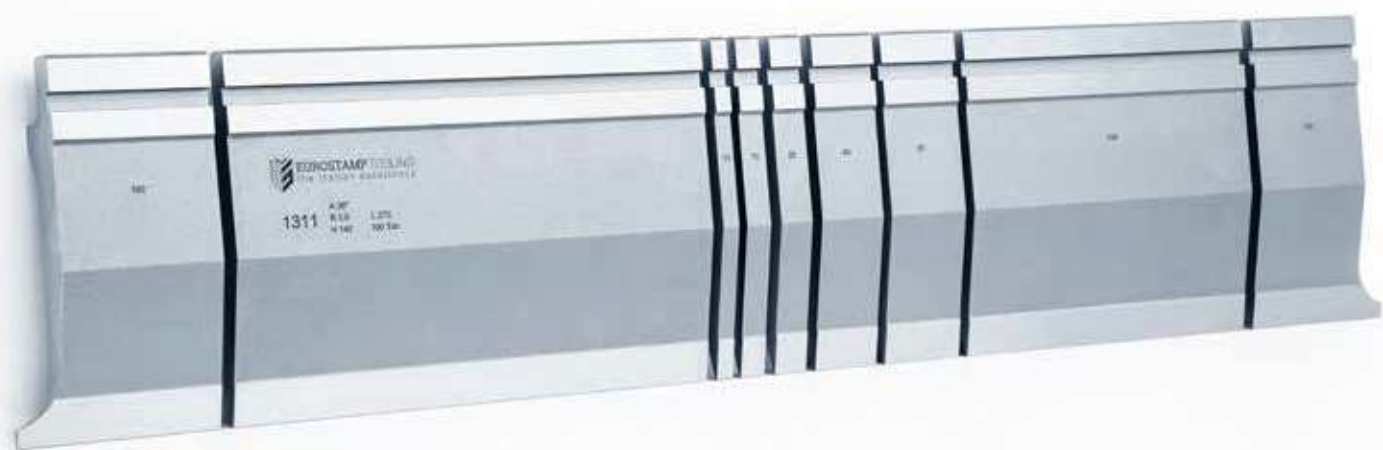



**EUROSTAMP** TOOLING  
the Italian excellence

# ESH

EUROSTAMP SAME HEIGHT



## UTENSILI SERIE ESH (Eurostamp Same Height)

EUROSTAMP ESPANDE LA PROPRIA GAMMA INTRODUCENDO UNA NUOVA SERIE COMPLETA DI UTENSILI (SUPERIORI ED INFERIORI) CONFORMI AI SISTEMI DI STAFFAGGIO STILE EUROPEO (AMADA/PROMECAM).

*EUROSTAMP IS EXPANDING ITS PRODUCT RANGE BY INTRODUCING A FULLY NEW SERIES (UPPER AND LOWER) THAT CONFORMS TO THE EUROPEAN STYLE CLAMPING SYSTEM (AMADA/PROMECAM STYLE).*

### CARATTERISTICHE COMUNI

Tutti gli utensili della serie sono prodotti utilizzando acciaio premium al CrMo che, grazie all'elevato carico di rottura (950-1050 N/mm<sup>2</sup>), consente di raggiungere tonnellaggi più elevati a parità di sezioni degli utensili.

Il trattamento di indurimento degli utensili è differenziato fra punzoni e matrici, per ottenere le migliori prestazioni in base alla loro differente modalità di utilizzo.

### COMMON FEATURES

*All tooling among this series is produced with high quality "premium" CrMo steel that, thanks to its superior tensile strength (950-1050 N/mm<sup>2</sup>), allows to withstand the highest tonnages even with small tool sections.*

*The tooling thermal treatment is differentiated between punches and dies, to obtain the best performance according to their different working condition.*

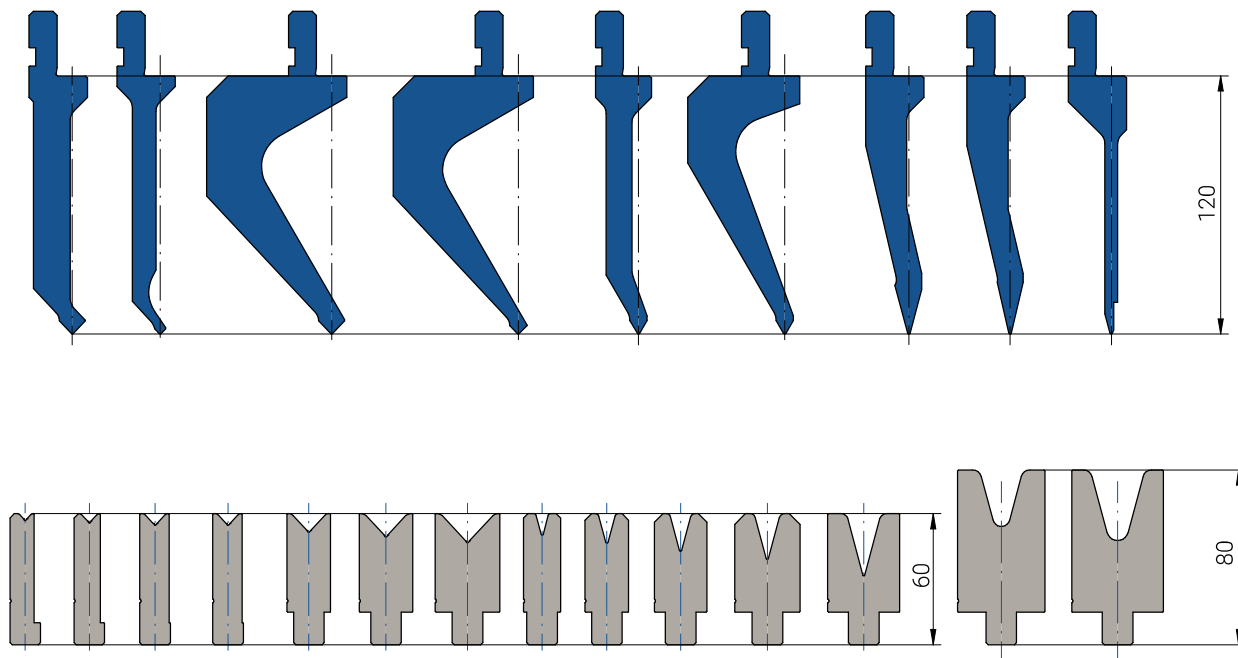

## INNOVAZIONE NEGLI UTENSILI SUPERIORI

Punzoni temprati ad induzione sulla punta fino a 55-58 HRC e per una profondità media di oltre 3mm: elevata durezza del raggio di punta e di tutta la superficie a contatto con la lamiera.

La gamma comprende punzoni con angoli ad 86°; 60°; 30°; 26°.

Forme dei punzoni ridisegnate per ottenere la massima flessibilità (quantità di profili fabbricabili).

Altezza di lavoro 120mm: adattabile alle caratteristiche di luce e corsa della maggior parte di piegatrici presenti sul mercato.

Altezza di lavoro identica per tutti i punzoni della gamma: possibilità di fabbricare profili complessi con angoli a 90° installando qualunque punzone in modalità "a stazioni (staged)".

## UPPER TOOLING INNOVATION

*Punches are hardened by induction on their tip, up to 55-58 HRC, at a depth of more than 3mm: extreme hardness of the punch tip in order to grant a larger lifespan.*

*Wide range of angles: 86°; 60°; 30°; 26°.*

*The punch shapes have been redesigned, based on years of experience, in order to improve their effectiveness and flexibility (quantity of feasible product profiles).*

*Working height is 120mm: it can fit on almost any daylight and stroke dimension, making these punches installable on almost any press brakes available in the market.*

*All the punches working height is exactly the same to allow the fabrication of complex products whose angles are 90° by installing the punches in stages (bending stations).*

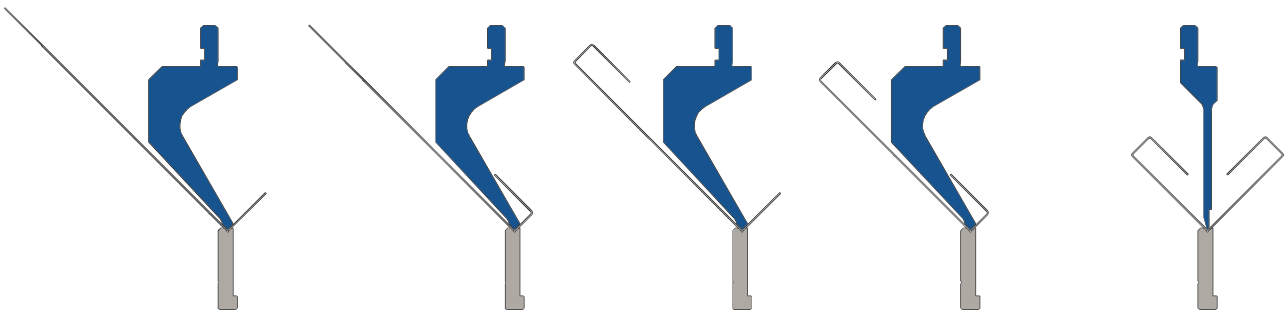

## INNOVAZIONE NEGLI UTENSILI INFERIORI

Inseri matrice sottoposti a nitrurazione: tutta la superficie della matrice, e non solamente le spalle, è rivestita da un sottile strato di nitruro con durezza fino a 65 HRC: importante riduzione del rischio di danneggiamento delle pareti laterali della V e significativa riduzione dell'adesione superficiale di particelle estranee (zinco e altre polveri) alle spalle e alle pareti della V.

La superficie delle matrici, infine, viene sottoposta a fosfatazione per incrementarne la protezione dall'ossidazione.

La gamma comprende inserti matrice ad 86° e a 30° con ampiezze da 6 a 25mm.

## LOWER TOOLING INNOVATIONS (INSERT DIE ARCHITECTURE)

*The insert dies are gas-nitrided; the whole tool external surface (not only its shoulders) is coated by a thin nitride layer whose hardness is up to 65 HRC: the significant increase of the surface hardness do not only improves the die shoulder resistance to the friction against the sheet surface, but, because even the die groove tilted sides have the same hardness, their wearing is reduced, as well as it's reduced the adhesion of foreign particles (Zink and other dust) that could cause the "galling" phenomenon.*

*The die surface is, then, subjected to a phosphate conversion coating, that's the reason of their black color. This treatment increases the die surface protection against the oxidation.*

*The die inserts widths range goes from 6 to 25mm at 86° and 30°.*

Forme degli inserti matrice ridisegnate per adeguarle alle esigenze odierne:

Ampi raggi di raccordo (per ridurre l'entità di eventuali impronte sulla lamiera).

Il corpo degli inserti matrice con larghezza di V di dimensioni ridotte, è stato modificato per offrire una maggiore versatilità nella fabbricazione di pieghe più complesse come quelle che prevedono contro pieghe.

Gli angoli esterni degli inserti matrice sono dotati di smussi che riducono la probabilità di collisioni con eventuali deformazioni posizionate in prossimità delle linee di piega.

The die inserts shape has been re-designed according to the actual fabrication requirements:

Wide shoulder radii (to decrease the risk of sheet marking).

The small V width insert dies body has been relieved: its thinner dimension will help to fabricate more complex product profiles, like short offset bends (frequently required when working with thin sheets).

Some of the insert dies corners has been replaced by chamfers, in order to decrease the probability of collisions against obstacles (burrings, deformations...) located even very near to the bending line.

**FORNITURE DISPONIBILI COME OPZIONE (a pagamento)**

A richiesta, anche i punzoni possono essere sottoposti al trattamento di fosfatazione, costituito da un rivestimento superficiale a base di fosfato che ricopre la superficie con uno strato cristallino protettivo in grado di conferire una elevata resistenza alla corrosione.

Il costo del trattamento varia in funzione del peso.

**OPTIONAL ADD-ON**

The punches surfaces could be subjected to phosphate conversion coating: chemical treatment that creates a thin adhering layer of phosphates, to achieve corrosion resistance and lubrication.

The treatment additional cost will be charged according to the total weight.

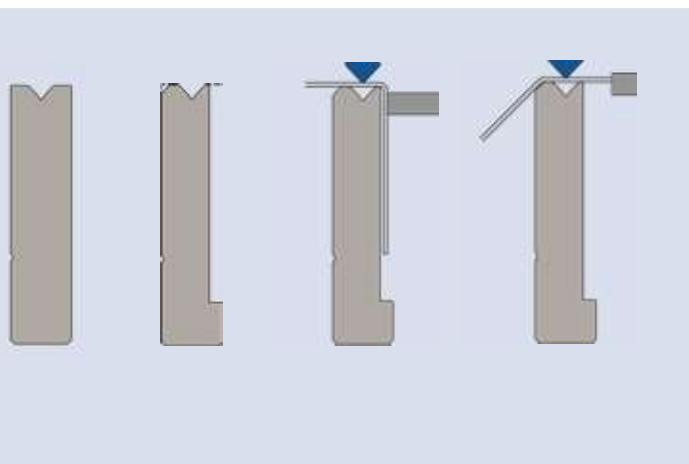

**INNOVAZIONE NELLA FRAZIONATURA STANDARD  
INNOVATION OF THE STANDARD SECTIONING**

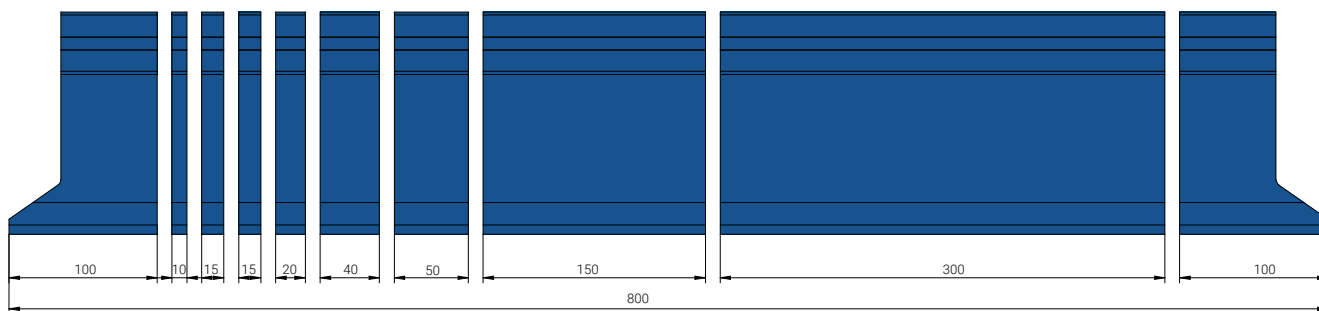

**UTENSILI SUPERIORI (LUNGHEZZA TOTALE 800MM):  
UPPER TOOLING (NEW TOTAL LENGTH 800MM):**

100mm SX - 10mm - 15mm - 15mm - 20mm - 40mm - 50mm - 150mm - 300mm - 100mm DX

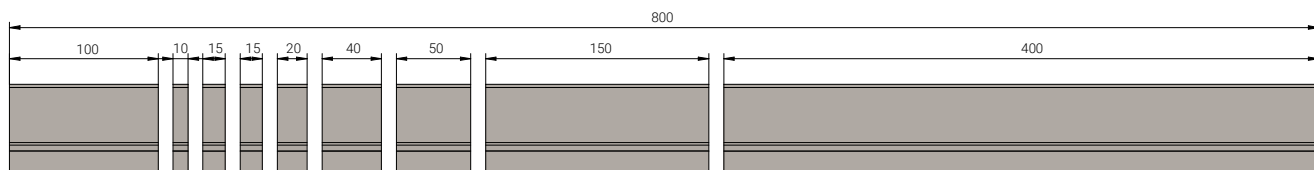

**UTENSILI INFERIORI (LUNGHEZZA TOTALE 800MM):  
LOWER TOOLS (NEW TOTAL LENGTH 800MM):**

100mm - 10mm - 15mm - 15mm - 20mm - 40mm - 50mm - 150mm - 400mm

**SCARPETTE ESH STANDARD  
STANDARD ESH HORN**

**SCARPETTE ESH STANDARD  
STANDARD ESH HORN**

**UTENSILI SUPERIORI  
LUNGHEZZA STANDARD 100MM  
UPPER TOOLS  
STANDARD LENGHT 100MM**

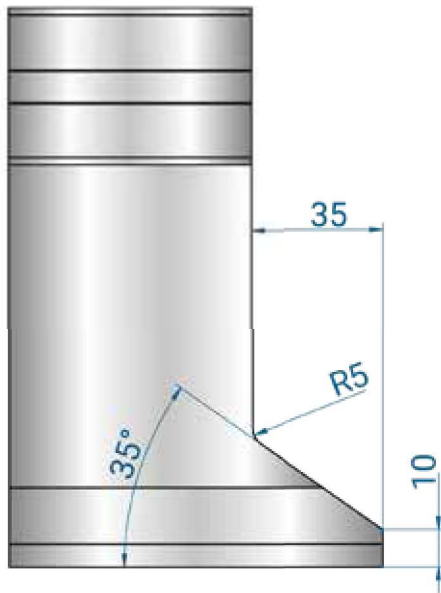

**1340, 1343, 1344,  
1345, 1346**

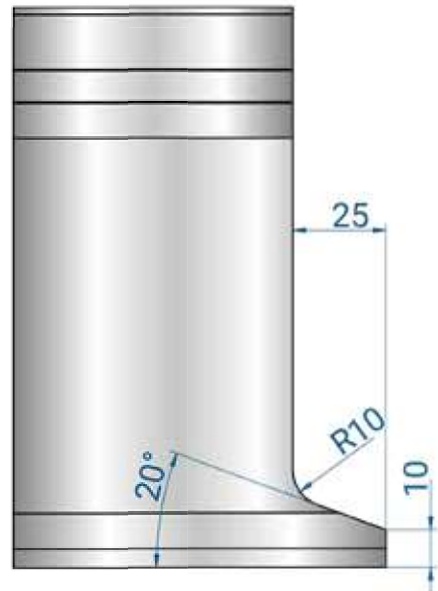

**1341, 1342, 1349**

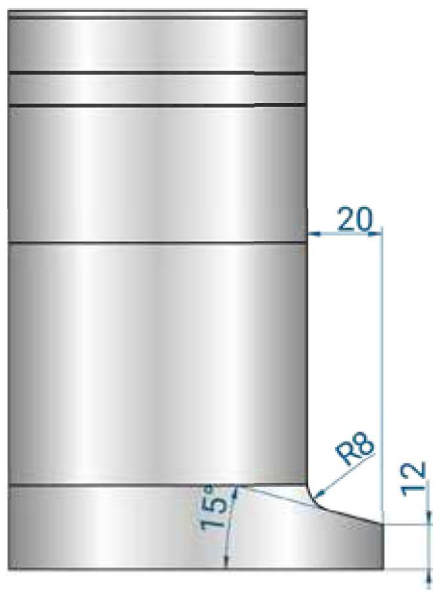

**1347, 1348**

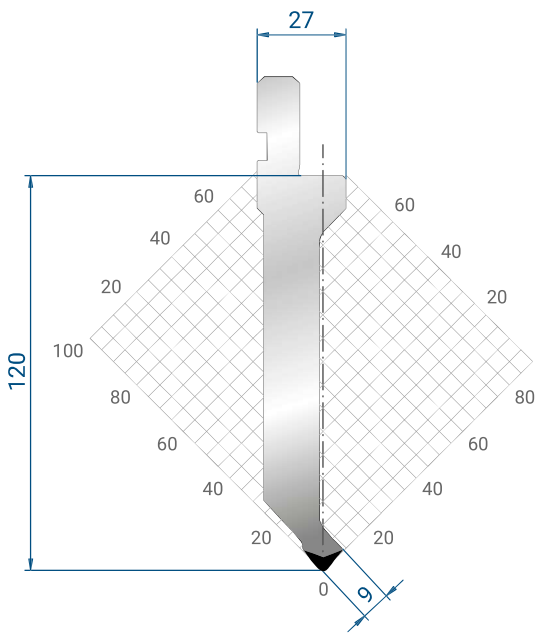

### 1340

**Mat** = CrMo Steel  
*bonificato/ tempered*  
**H** = 120 mm  
**Max T/m** = 100  
 $\alpha$  = 86°  
**R** = 0.6

835 mm	15,6 kg
415 mm	7,8 kg
800 mm	13,8 kg
FRAZ. / SECT.	

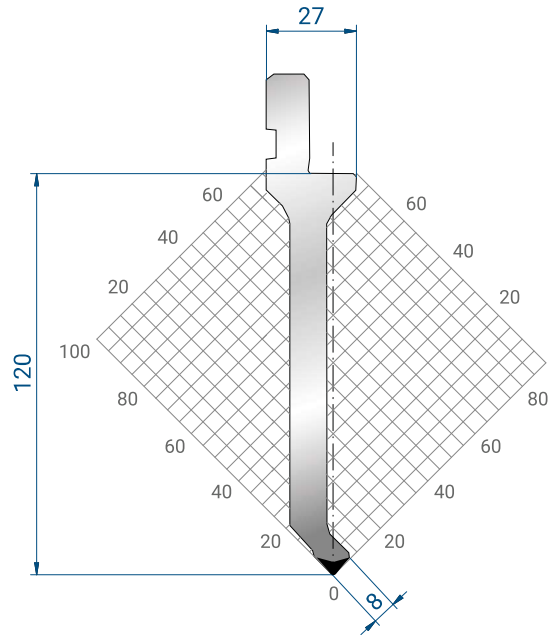

### 1341

**Mat** = CrMo Steel  
*bonificato/ tempered*  
**H** = 120 mm  
**Max T/m** = 50  
 $\alpha$  = 86°  
**R** = 0.6

835 mm	11,7 kg
415 mm	5,8 kg
800 mm	10,6 kg
FRAZ. / SECT.	

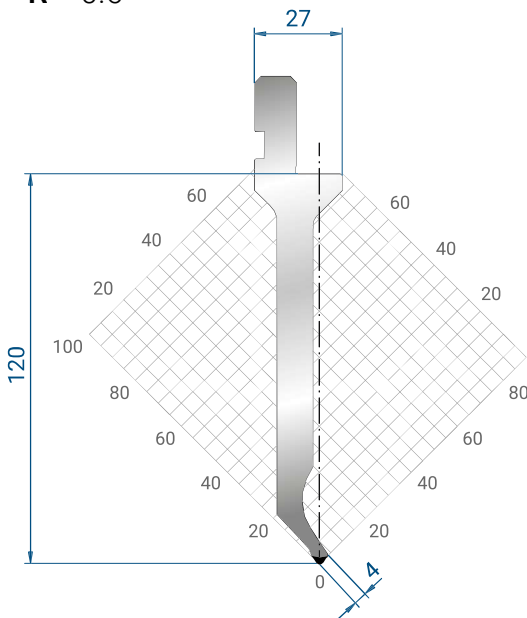

### 1342

**Mat** = CrMo Steel  
*bonificato/ tempered*  
**H** = 120 mm  
**Max T/m** = 30  
 $\alpha$  = 86°  
**R** = 0.6

835 mm	11,2 kg
415 mm	5,5 kg
800 mm	10,0 kg
FRAZ. / SECT.	

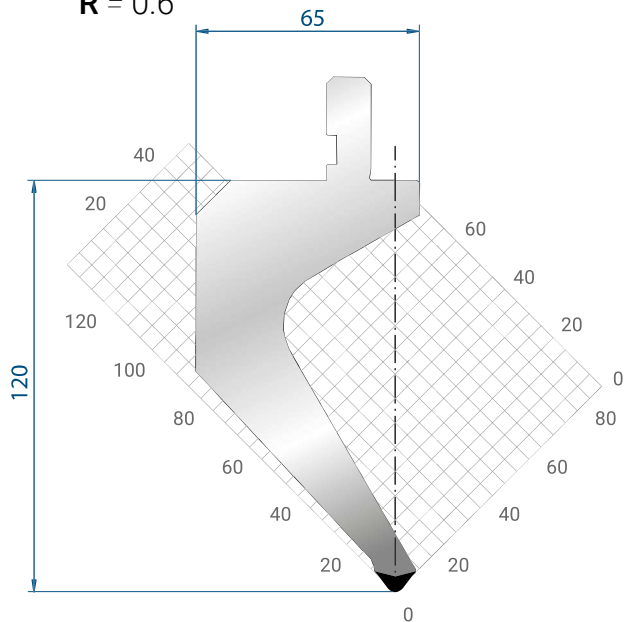

### 1343

**Mat** = CrMo Steel  
*bonificato/ tempered*  
**H** = 120 mm  
**Max T/m** = 50  
 $\alpha$  = 86°  
**R** = 0.6

835 mm	26,6 kg
415 mm	12,5 kg
800 mm	22,2 kg
FRAZ. / SECT.	

## PUNZONI 86° / PUNCH 86°

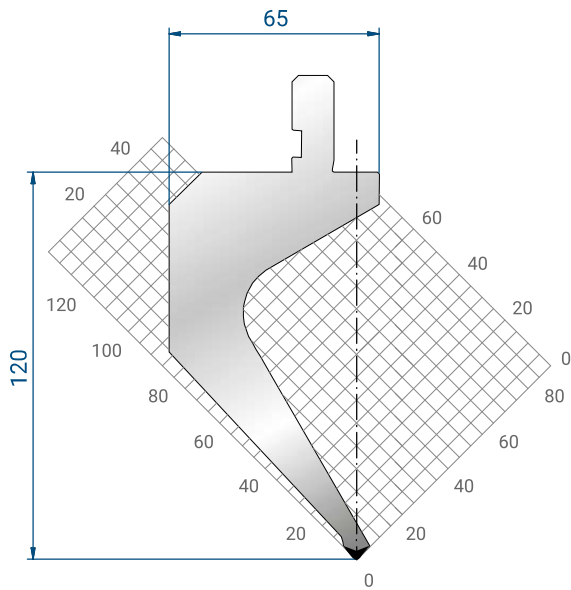

### 1344

**Mat** = CrMo Steel  
*bonificato/ tempered*  
**H** = 120 mm  
**Max T/m** = 45  
 $\alpha$  = 86°  
**R** = 0.6

835 mm	23,4 kg
415 mm	11,7 kg
800 mm	20,6 kg
FRAZ. / SECT.	

## PUNZONI 60° / PUNCH 60°

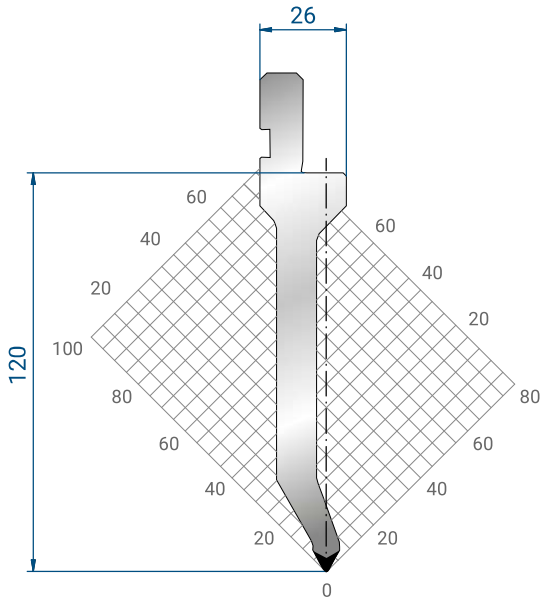

### 1345

**Mat** = CrMo Steel  
*bonificato/ tempered*  
**H** = 120 mm  
**Max T/m** = 70  
 $\alpha$  = 60°  
**R** = 0.6

835 mm	12,4 kg
415 mm	6,2 kg
800 mm	11,0 kg
FRAZ. / SECT.	

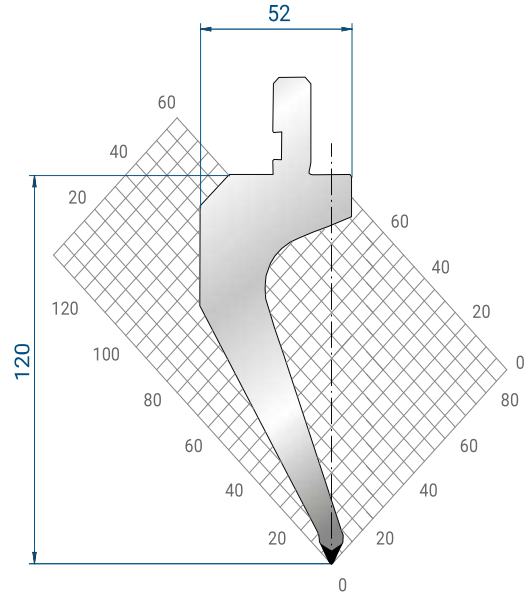

### 1346

**Mat** = CrMo Steel  
*bonificato/ tempered*  
**H** = 120 mm  
**Max T/m** = 70  
 $\alpha$  = 60°  
**R** = 0.6

835 mm	19,2 kg
415 mm	9,6 kg
800 mm	16,9 kg
FRAZ. / SECT.	

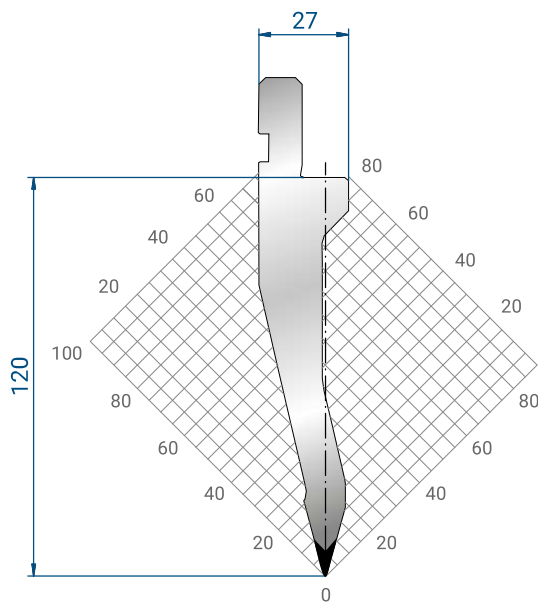

### 1347

**Mat** = CrMo Steel  
*bonificato/ tempered*  
**H** = 120 mm  
**Max T/m** = 100  
 $\alpha$  = 30°  
**R** = 0.6

835 mm	14,0 kg
415 mm	7,0 kg
800 mm FRAZ. / SECT.	12,8 kg

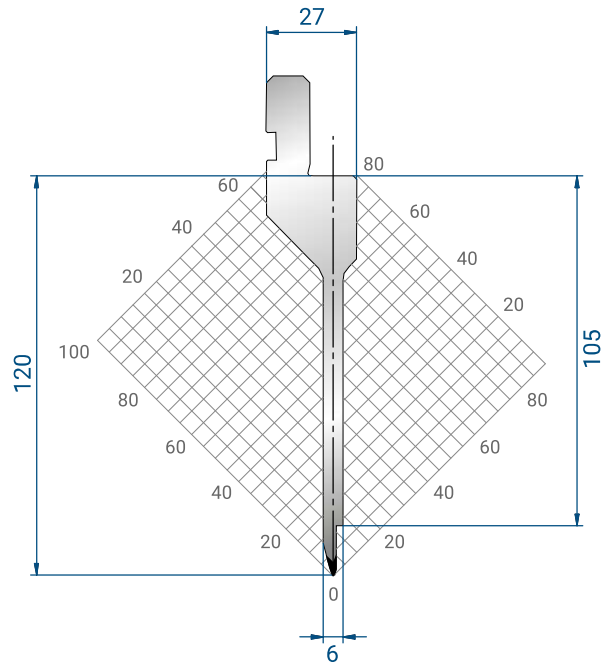

### 1349

**Mat** = CrMo Steel  
*bonificato/ tempered*  
**H** = 120 mm  
**Max T/m** = 45  
 $\alpha$  = 30°  
**R** = 0.6

835 mm	13,9 kg
415 mm	4,9 kg
800 mm FRAZ. / SECT.	8,8 kg

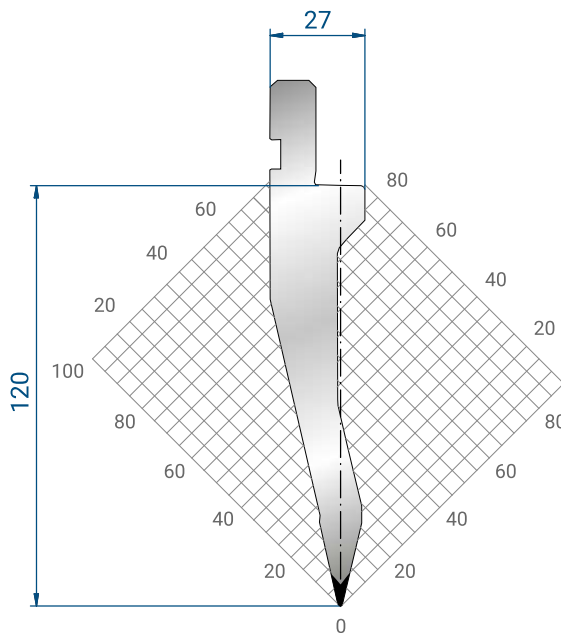

### 1348

**Mat** = CrMo Steel  
*bonificato/ tempered*  
**H** = 120 mm  
**Max T/m** = 100  
 $\alpha$  = 26°  
**R** = 0.6

835 mm	13,9 kg
415 mm	6,9 kg
800 mm FRAZ. / SECT.	12,7 kg

**SUPPORTO PER INSERTI MATRICE ESH  
ESH DIES INSERT HOLDER**

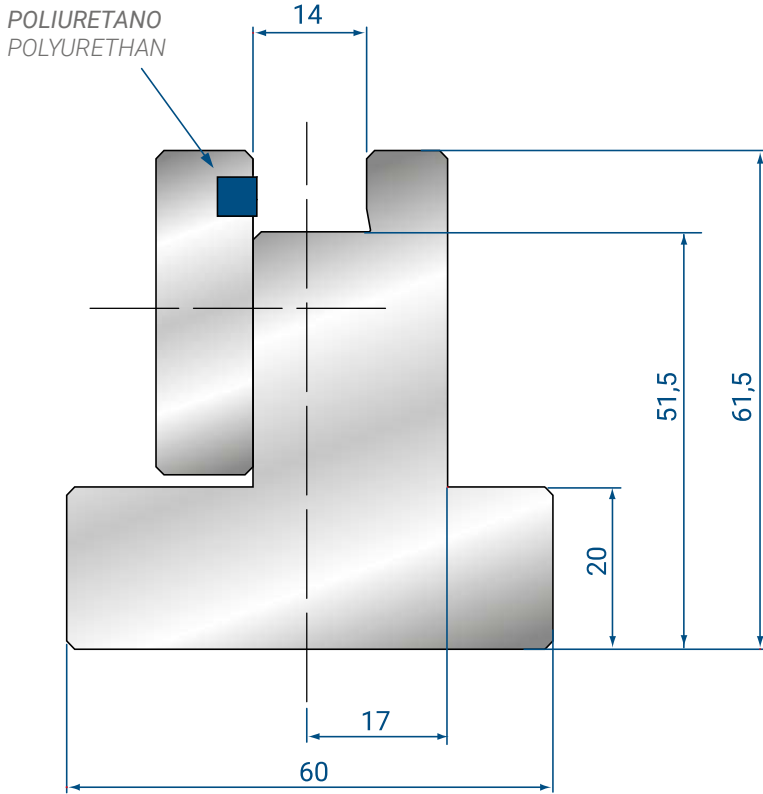

**3173**

835 mm	17,0 kg
415 mm	8,0 kg

ESEMPIO DI MONTAGGIO  
ASSEMBLY EXAMPLE

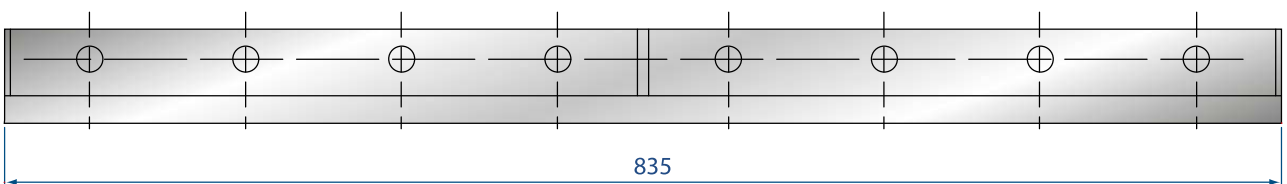
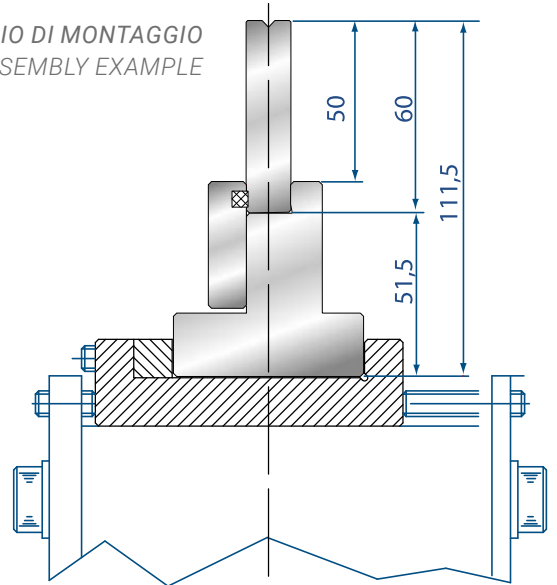

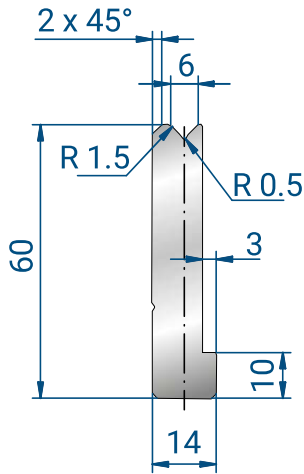

### 3320 - V6

**Mat** = CrMo Steel  
*nitrurato e fosfatato/  
nitrided and  
phosphatized*

**H** = 60 mm

**Max T/m** = 80

$\alpha$  = 86°

**R** = 1.5

835 mm	4,4 kg
415 mm	2,2 kg
800 mm FRAZ. / SECT.	4,2 kg

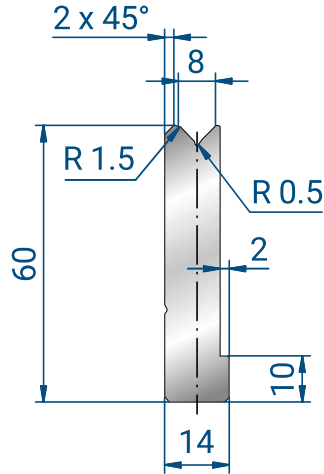

### 3321 - V8

**Mat** = CrMo Steel  
*nitrurato e fosfatato/  
nitrided and  
phosphatized*

**H** = 60 mm

**Max T/m** = 90

$\alpha$  = 86°

**R** = 1.5

835 mm	4,7 kg
415 mm	2,3 kg
800 mm FRAZ. / SECT.	4,5 kg

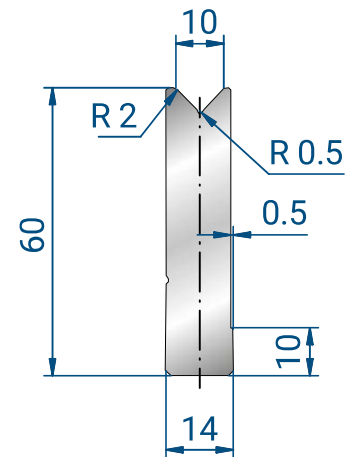

### 3322 - V10

**Mat** = CrMo Steel  
*nitrurato e fosfatato/  
nitrided and  
phosphatized*

**H** = 60 mm

**Max T/m** = 100

$\alpha$  = 86°

**R** = 2

835 mm	5,1 kg
415 mm	2,5 kg
800 mm FRAZ. / SECT.	4,9 kg

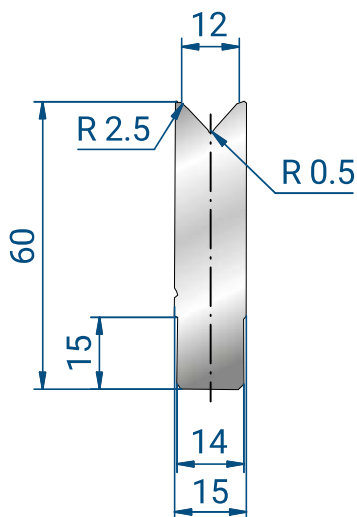

### 3323 - V12

**Mat** = CrMo Steel  
*nitrurato e fosfatato/  
nitrided and  
phosphatized*

**H** = 60 mm

**Max T/m** = 100

$\alpha$  = 86°

**R** = 2.5

835 mm	5,5 kg
415 mm	2,7 kg
800 mm FRAZ. / SECT.	5,3 kg

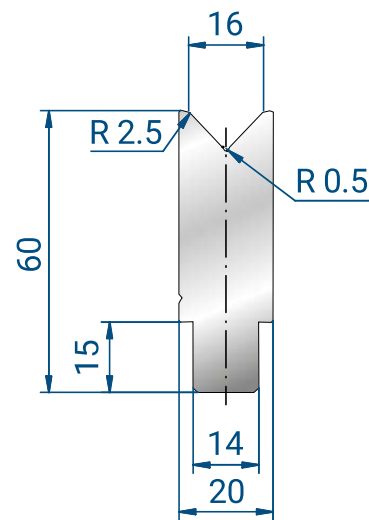

### 3324 - V16

**Mat** = CrMo Steel  
*nitrurato e fosfatato/  
nitrided and  
phosphatized*

**H** = 60 mm

**Max T/m** = 100

$\alpha$  = 86°

**R** = 2.5

835 mm	6,8 kg
415 mm	3,4 kg
800 mm FRAZ. / SECT.	6,5 kg

**INSERTI MATRICE 86°  
ESH 86° INSERT DIES**

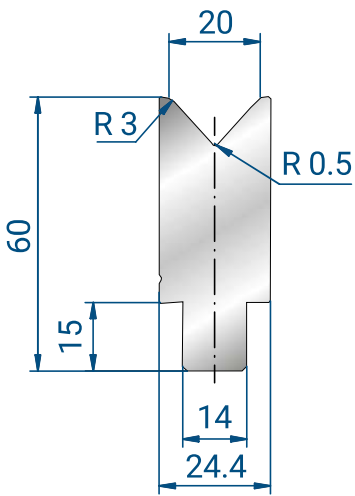

**3325 - V20**

**Mat** = CrMo Steel  
*nitrurato e fosfatato/  
nitrided and  
phosphatized*  
**H** = 60 mm  
**Max T/m** = 100  
**α** = 86°  
**R** = 3

835 mm	7,8 kg
415 mm	3,9 kg
800 mm	7,5 kg
FRAZ. / SECT.	

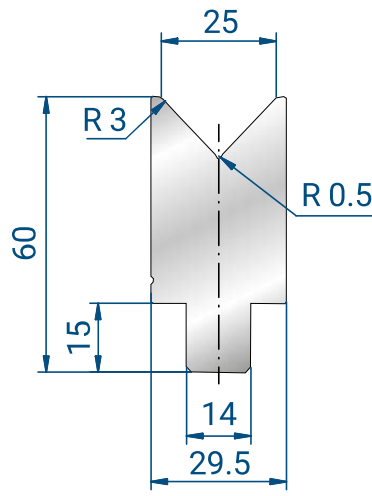

**3326 - V25**

**Mat** = CrMo Steel  
*nitrurato e fosfatato/  
nitrided and  
phosphatized*  
**H** = 60 mm  
**Max T/m** = 100  
**α** = 86°  
**R** = 3

835 mm	8,9 kg
415 mm	4,4 kg
800 mm	8,6 kg
FRAZ. / SECT.	

**INSERTI MATRICE 30° - ESH 30° INSERT DIES**

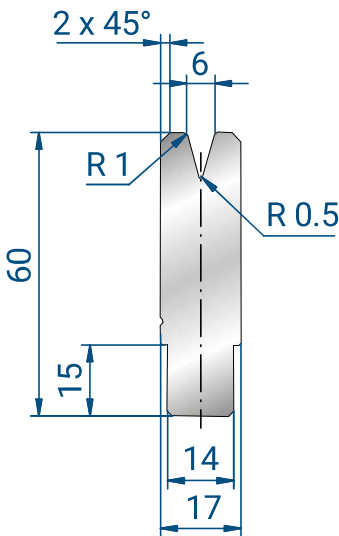

**3327 - V6**

**Mat** = CrMo Steel  
*nitrurato e fosfatato/  
nitrided and  
phosphatized*  
**H** = 60 mm  
**Max T/m** = 50  
**α** = 30°  
**R** = 1

835 mm	6,1 kg
415 mm	3,0 kg
800 mm	5,9 kg
FRAZ. / SECT.	

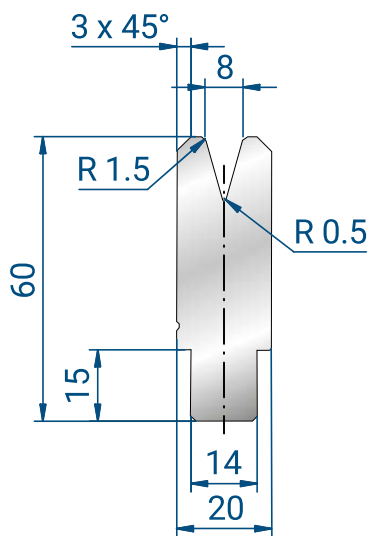

**3328 - V8**

**Mat** = CrMo Steel  
*nitrurato e fosfatato/  
nitrided and  
phosphatized*  
**H** = 60 mm  
**Max T/m** = 60  
**α** = 30°  
**R** = 1.5

835 mm	6,8 kg
415 mm	3,4 kg
800 mm	6,5 kg
FRAZ. / SECT.	

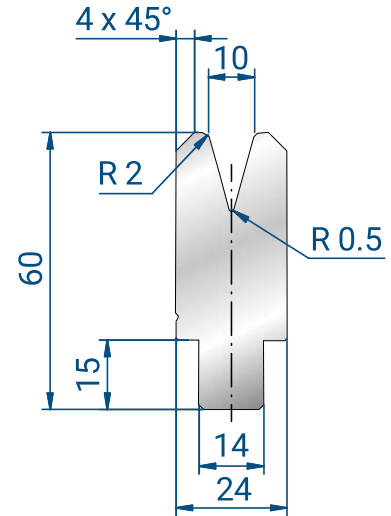

**3329 - V10**

**Mat** = CrMo Steel  
*nitrurato e fosfatato/  
nitrided and  
phosphatized*  
**H** = 60 mm  
**Max T/m** = 70  
**α** = 30°  
**R** = 2

835 mm	7,7 kg
415 mm	3,8 kg
800 mm	7,4 kg
FRAZ. / SECT.	

**INSERTI MATRICE 30°**  
**ESH 30° INSERT DIES**

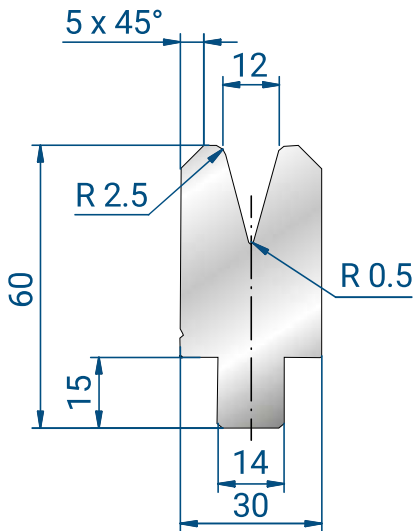

**3330 - V12**

**Mat** = CrMo Steel  
*nitrurato e fosfatato/  
nitrided and  
phosphatized*  
**H** = 60 mm  
**Max T/m** = 80  
**α** = 30°  
**R** = 2.5

835 mm	9,1 kg
415 mm	4,5 kg
800 mm	8,8 kg
FRAZ. / SECT.	

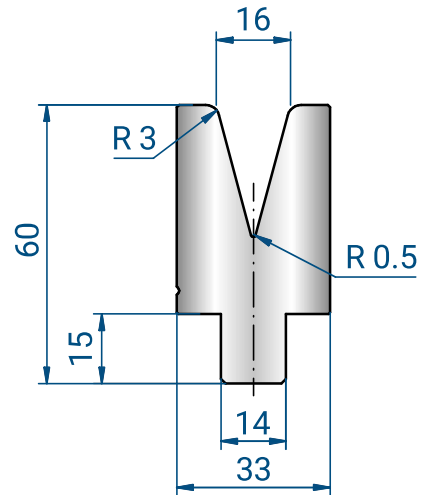

**3331 - V16**

**Mat** = CrMo Steel  
*nitrurato e fosfatato/  
nitrided and  
phosphatized*  
**H** = 60 mm  
**Max T/m** = 60  
**α** = 30°  
**R** = 3

835 mm	9,5 kg
415 mm	4,7 kg
800 mm	9,1 kg
FRAZ. / SECT.	

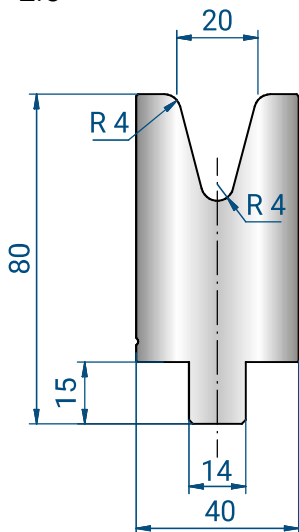

**3332 - V20**

**Mat** = CrMo Steel  
*nitrurato e fosfatato/  
nitrided and  
phosphatized*  
**H** = 80 mm  
**Max T/m** = 60  
**α** = 30°  
**R** = 4

835 mm	16,1 kg
415 mm	8,0 kg
800 mm	15,5 kg
FRAZ. / SECT.	

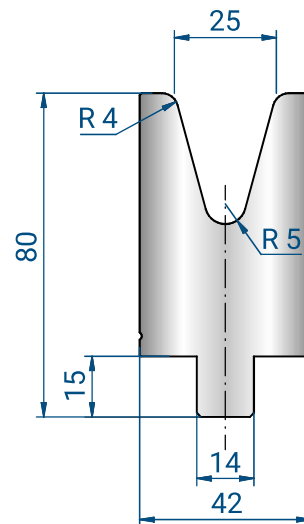

**3333 - V25**

**Mat** = CrMo Steel  
*nitrurato e fosfatato/  
nitrided and  
phosphatized*  
**H** = 80 mm  
**Max T/m** = 60  
**α** = 30°  
**R** = 4

835 mm	16,1 kg
415 mm	7,8 kg
800 mm	15,1 kg
FRAZ. / SECT.	



**EUROSTAMP** TOOLING  
the Italian excellence

# TRUMPF STYLE

**Gli utensili superiori e inferiori elencati in questa sezione possono essere installati sulle piegatrici:**

Trumpf, LVD, Darley, Safan e su altre piegatrici equipaggiate con Sistema NSCL.

Questi utensili possono essere installati anche su altre piegatrici tramite adattatori superiori e inferiori.

***The upper and lower tooling listed in this section could be installed on the following press brakes:***

*Trumpf, Darley, Safan, and other press brakes equipped with Wila style clamping system.*

*These tooling could even be installed on press brakes equipped with different clamping system by choosing the appropriate upper and lower adapters.*





VEDI PAG. 111 PER SCHEMA FRAZIONATURA MATRICI  
 SEE PAGE 111 FOR DIE SEGMENTATION DIAGRAM

LUNGHEZZE STANDARD  
 STANDARD LENGTHS

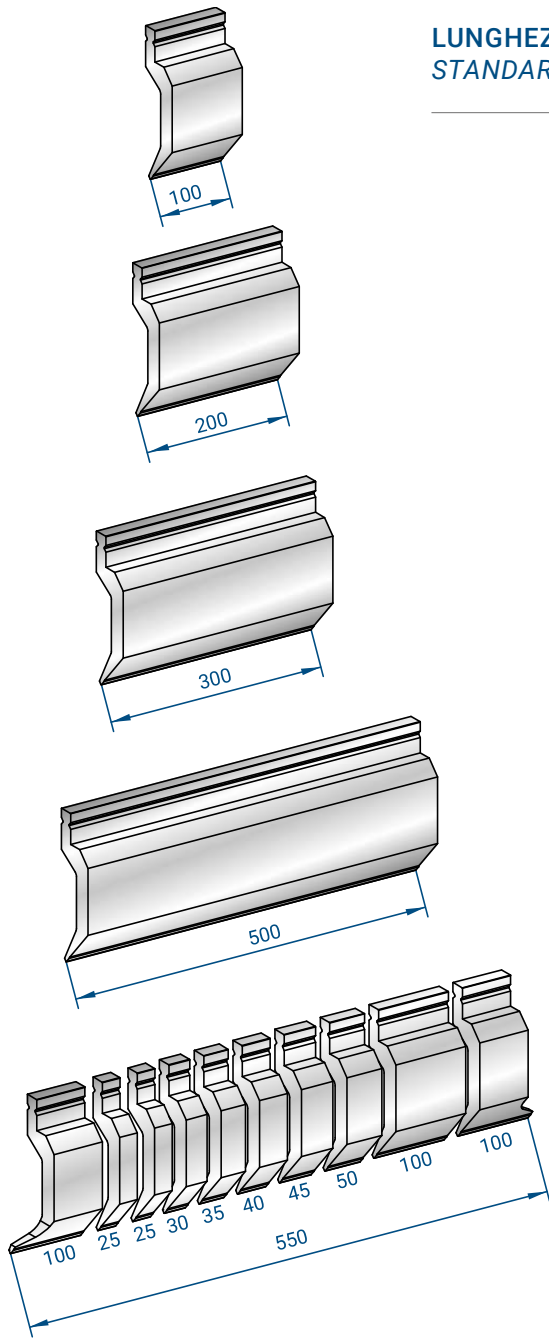

IL PULSANTE DI SICUREZZA VIENE MONTATO STANDARD SU TUTTI GLI UTENSILI CON PESO FINO A 13,5 KG

THE SAFETY BUTTON IS A STANDARD SUPPLY ON ALL TOOLING UP TO 13.5 KG WEIGH

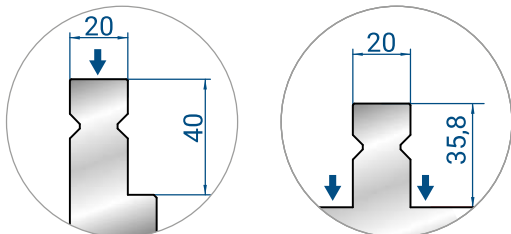

FRESATURA SCARPETTA  
 MILLED HORN

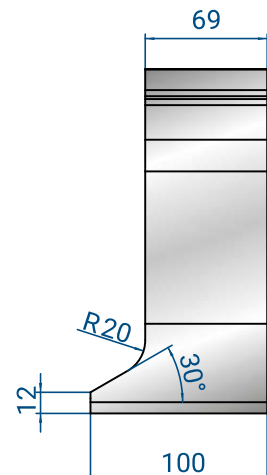

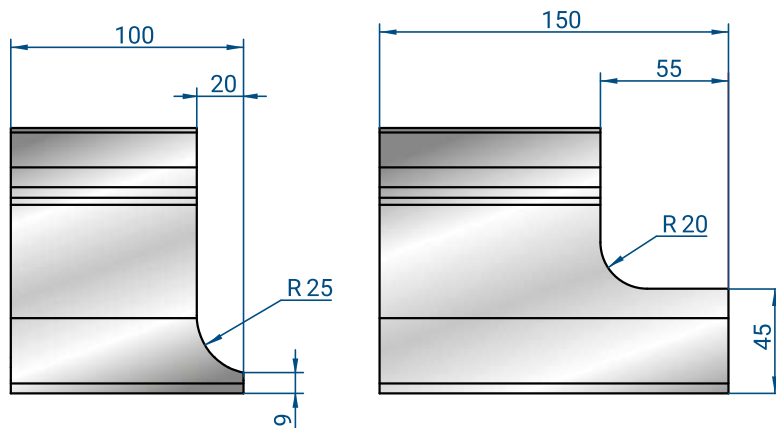

SCARPETTE SPECIALI  
SPECIAL HORNS

---



TAGLI SU RICHIESTA  
SPECIAL SEGMENTATION

---





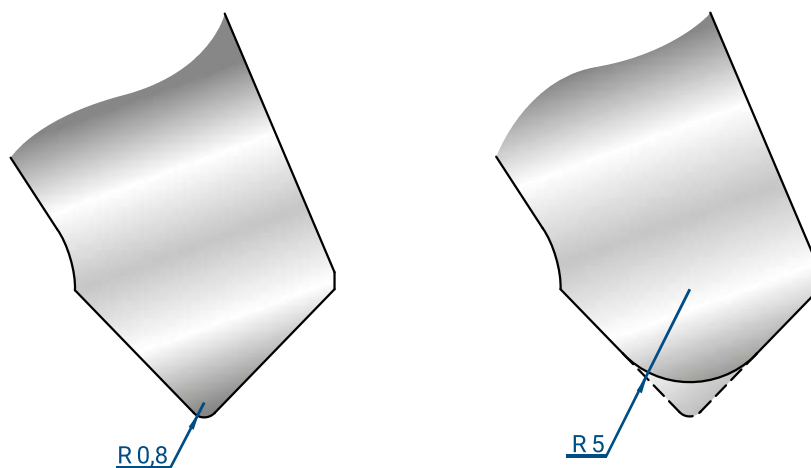





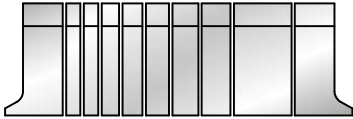

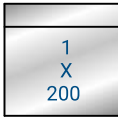

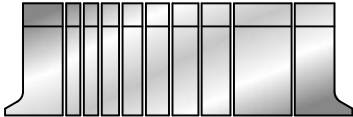
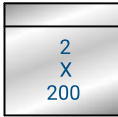
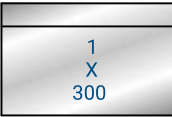
MODIFICA RAGGIO  
RADIUS MODIFICATION

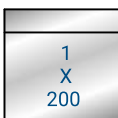
---

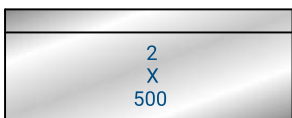

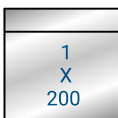

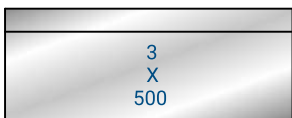
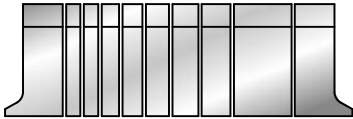
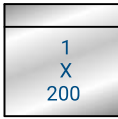

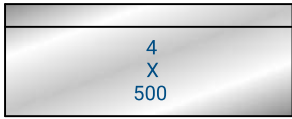
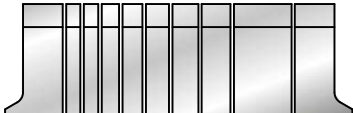
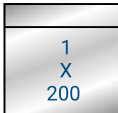
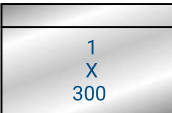
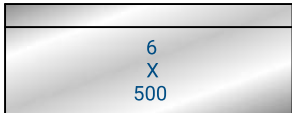





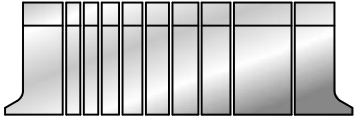

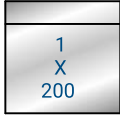

FRAZIONATURE PER PUNZONI  
SEGMENTATION FOR PUNCHES

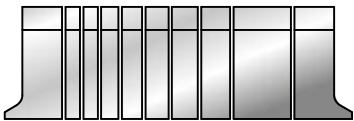
**1233 - 1234 - 1235 - 1236**  
**1237 - 1238 - 1295**  
**1302 - 1308 - 1313 - 1314**  
**1316 - 1317 - 1318**

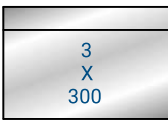
550				
1050				
1250				
2050				
2550				
3050				
4050				

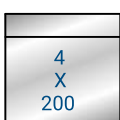
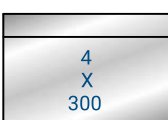

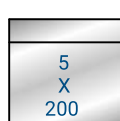
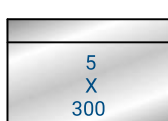

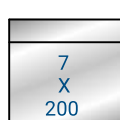
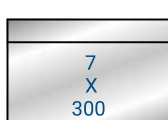
FRAZIONATURE PER PUNZONI  
SEGMENTATION FOR PUNCHES

1294 - 1303 - 1319 - 1320

550			
1050			
1250			
2050			
2550			
3050			
4050			

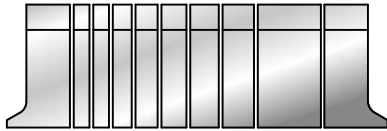
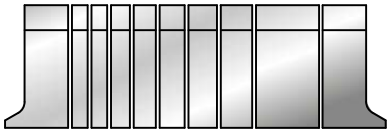
FRAZIONATURE PER PUNZONI  
SEGMENTATION FOR PUNCHES

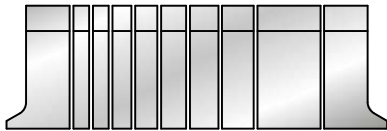
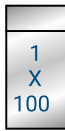
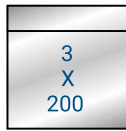
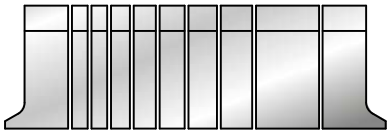
1315

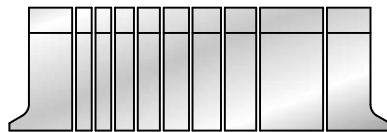
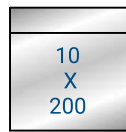
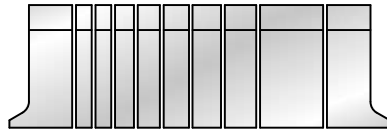
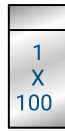
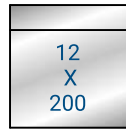
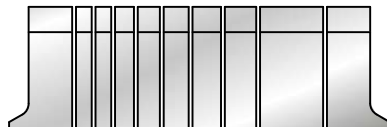
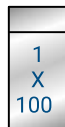
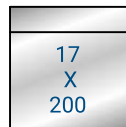
550			
1050			
1250			
2050			
2550			
3050			
4050			



# 1315

200 mm	19,6 kg
100 mm	6,6 kg
SCARP. /HORN	
550 mm	48,00kg
FRAZ. /SECT	
100 mm	9,8 kg
50 mm	4,9 kg
45 mm	4,4 kg
40 mm	3,9 kg
35 mm	3,4 kg
30 mm	2,9 kg
25 mm	2,5 kg

Mat = 42CrMo4  
 bonificato / tempered  
 H = 300.00  
 Max T/m = 80  
 $\alpha = 86^\circ$   
 R = 1

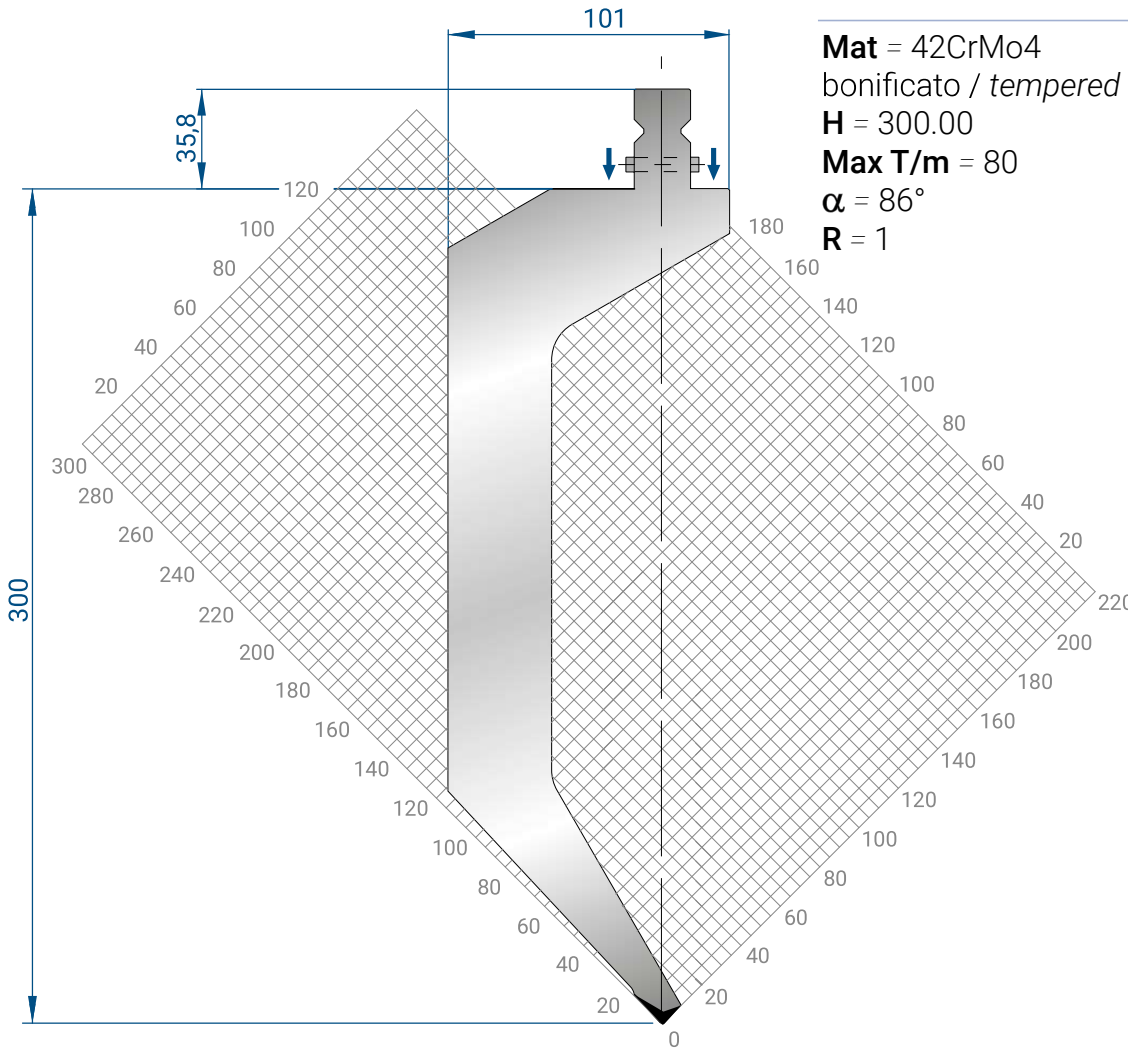

↓  
 SPINTA LATERALE  
 SHOULDER LOAD

# 1294

500 mm	33,6 kg
300 mm	20,1 kg
200 mm	13,4 kg
100 mm	6,7 kg
550 mm	29,6 kg
FRAZ. /SECT	
100 mm	4,7 kg
SCARP. /HORN	
50 mm	3,4 kg
45 mm	3,0 kg
40 mm	2,7 kg
35 mm	2,4 kg
30 mm	2,0 kg
25 mm	1,7 kg

Mat = 42CrMo4  
 bonificato / tempered  
 H = 220.00  
 Max T/m = 85  
 $\alpha = 86^\circ$   
 R = 1

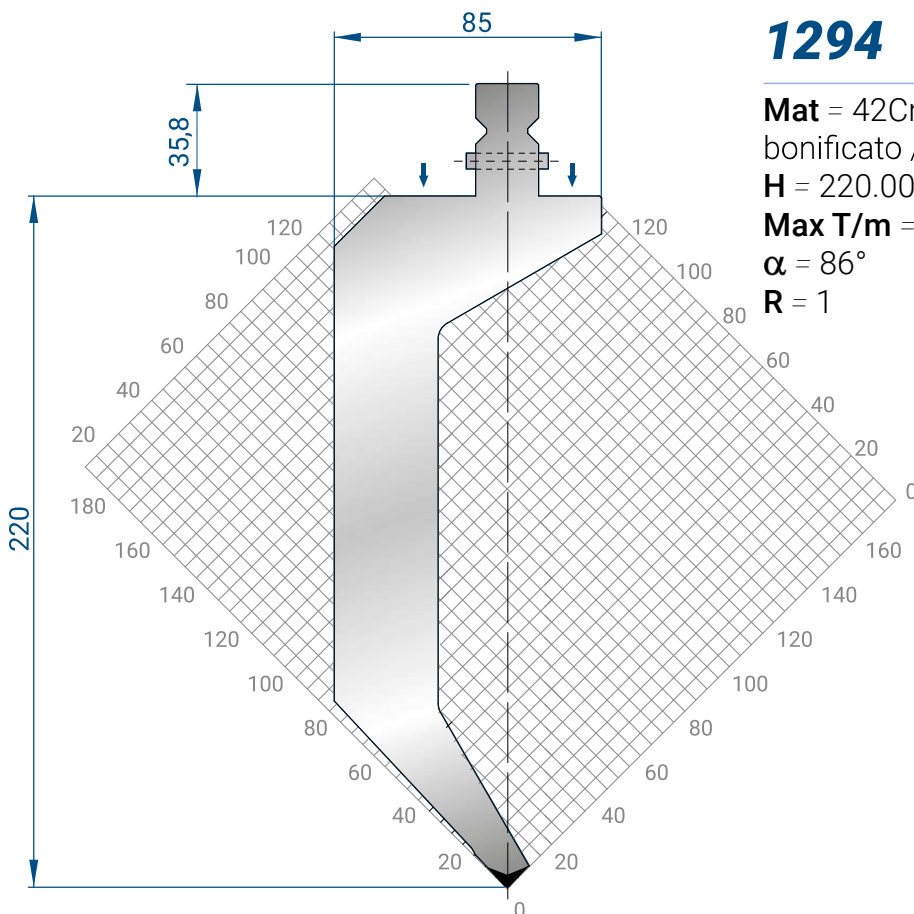

↓  
 SPINTA LATERALE  
 SHOULDER LOAD

## 1320

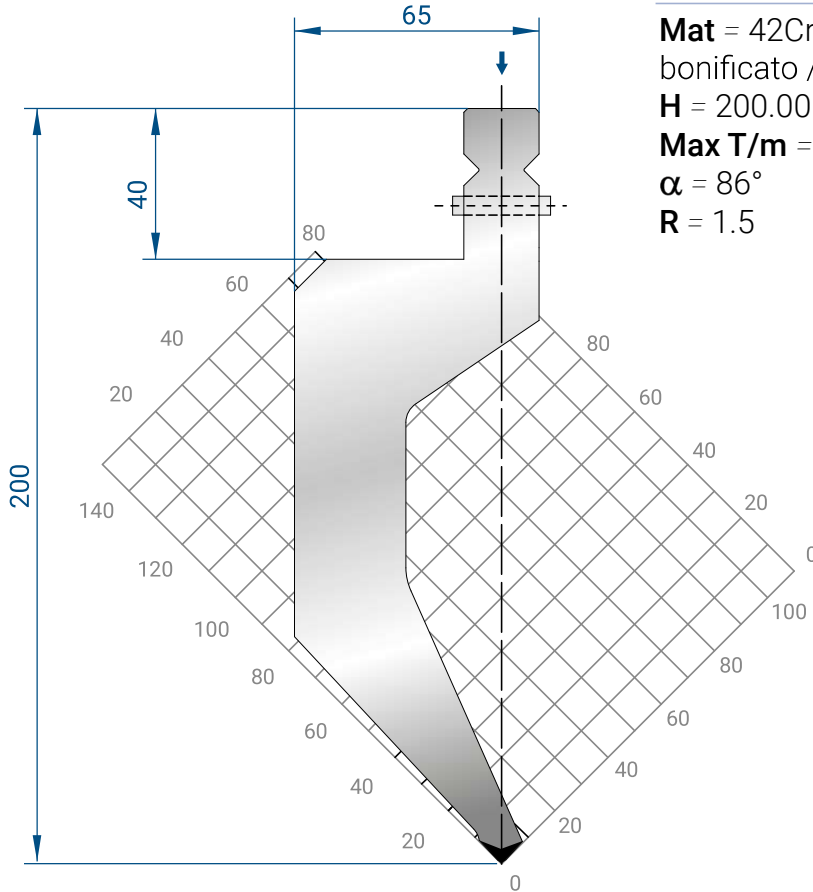

**Mat** = 42CrMo4  
 bonificato / *tempered*  
**H** = 200.00  
**Max T/m** = 100  
 $\alpha$  = 86°  
**R** = 1.5

500 mm	23,6 kg
300 mm	14,1 kg
200 mm	9,4 kg
100 mm	4,7 kg
550 mm FRAZ. /SECT.	23,2 kg
100 mm SCARP. /HORN	3,3 kg
50 mm	2,4 kg
45 mm	2,1 kg
40 mm	1,9 kg
35 mm	1,7 kg
30 mm	1,4 kg
25 mm	1,2 kg

↓  
 SPINTA IN TESTA  
 HEAD LOAD

## 1233

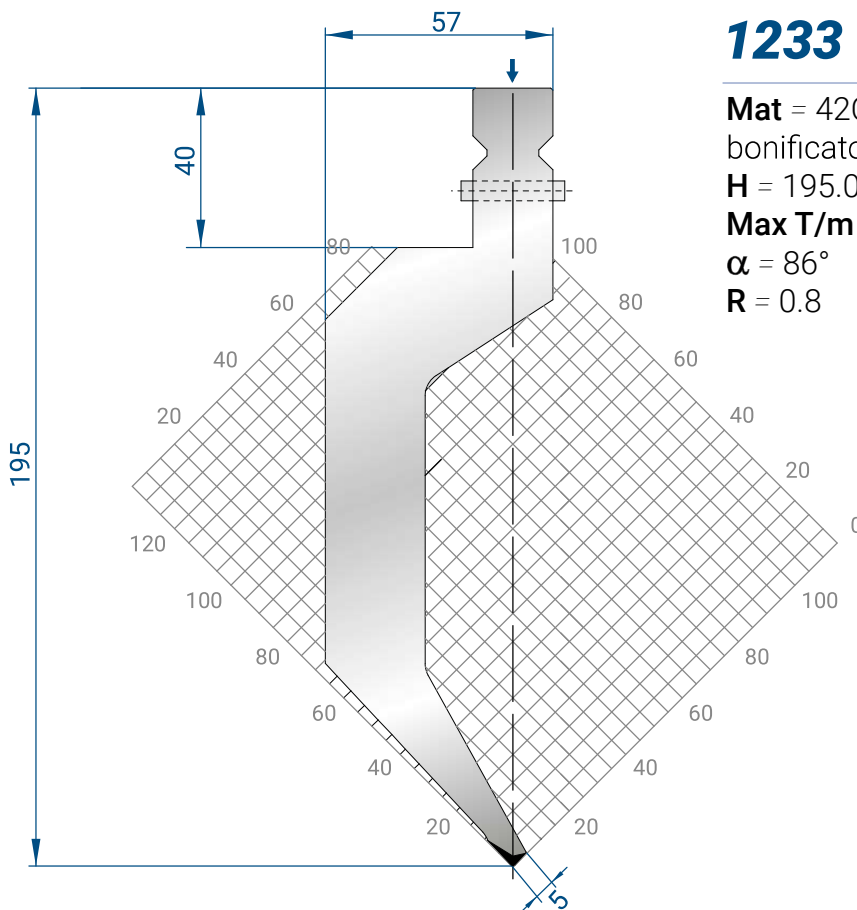

**Mat** = 42CrMo4  
 bonificato / *tempered*  
**H** = 195.00  
**Max T/m** = 40  
 $\alpha$  = 86°  
**R** = 0.8

500 mm	18,4 kg
300 mm	11,0 kg
200 mm	7,4 kg
100 mm	3,7 kg
550 mm FRAZ. /SECT	18,1 kg
100 mm SCARP. /HORN	2,6 kg
50 mm	1,8 kg
45 mm	1,7 kg
40 mm	1,5 kg
35 mm	1,3 kg
30 mm	1,1 kg
25 mm	0,9 kg

↓  
 SPINTA IN TESTA  
 HEAD LOAD

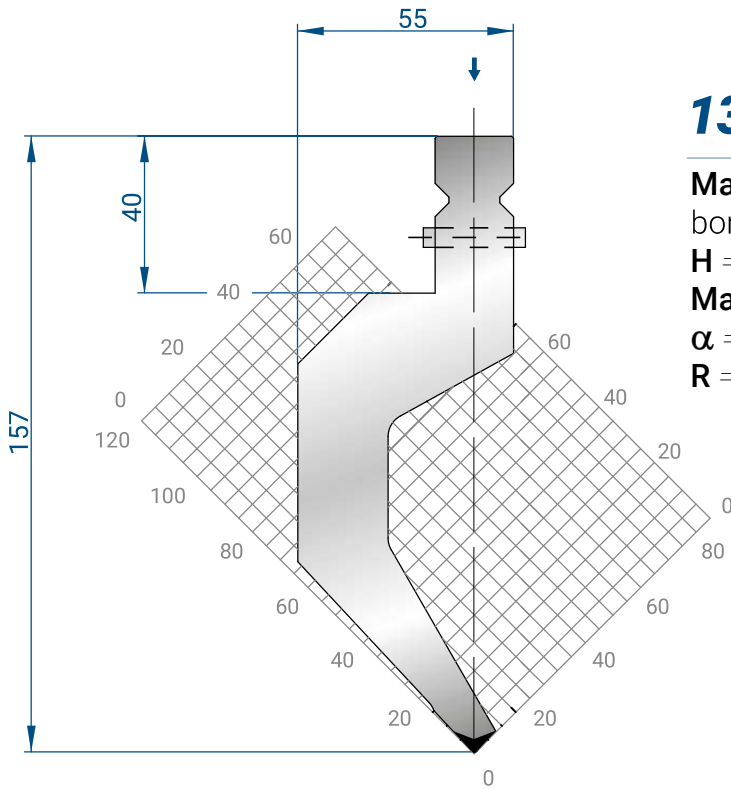

## 1314

**Mat** = 42CrMo4  
 bonificato / *tempered*  
**H** = 157.00  
**Max T/m** = 80  
 $\alpha$  = 86°  
**R** = 1

500 mm	14,6 kg
300 mm	8,8 kg
200 mm	5,9 kg
100 mm	2,9 kg
550 mm FRAZ. / SECT.	13,0 kg
100 mm SCARP. / HORN	2,1 kg
50 mm	1,5 kg
45 mm	1,3 kg
40 mm	1,2 kg
35 mm	1,0 kg
30 mm	0,9 kg
25 mm	0,7 kg

↓  
 SPINTA IN TESTA  
 HEAD LOAD

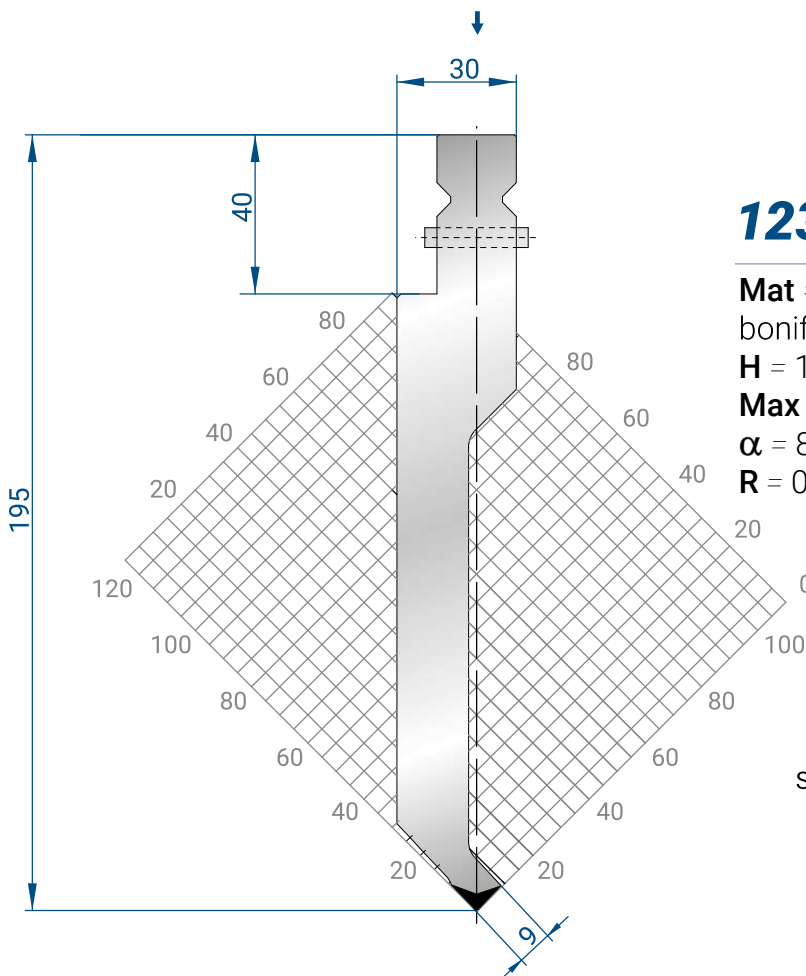

## 1235

**Mat** = 42CrMo4  
 bonificato / *tempered*  
**H** = 195.00  
**Max T/m** = 100  
 $\alpha$  = 86°  
**R** = 0.8

500 mm	14,8 kg
300 mm	8,9 kg
200 mm	5,9 kg
100 mm	3,0 kg
550 mm FRAZ. / SECT.	14,5 kg
100 mm SCARP. / HORN	2,1 kg
50 mm	1,5 kg
45 mm	1,3 kg
40 mm	1,2 kg
35 mm	1,0 kg
30 mm	0,9 kg
25 mm	0,7 kg

↓  
 SPINTA IN TESTA  
 HEAD LOAD

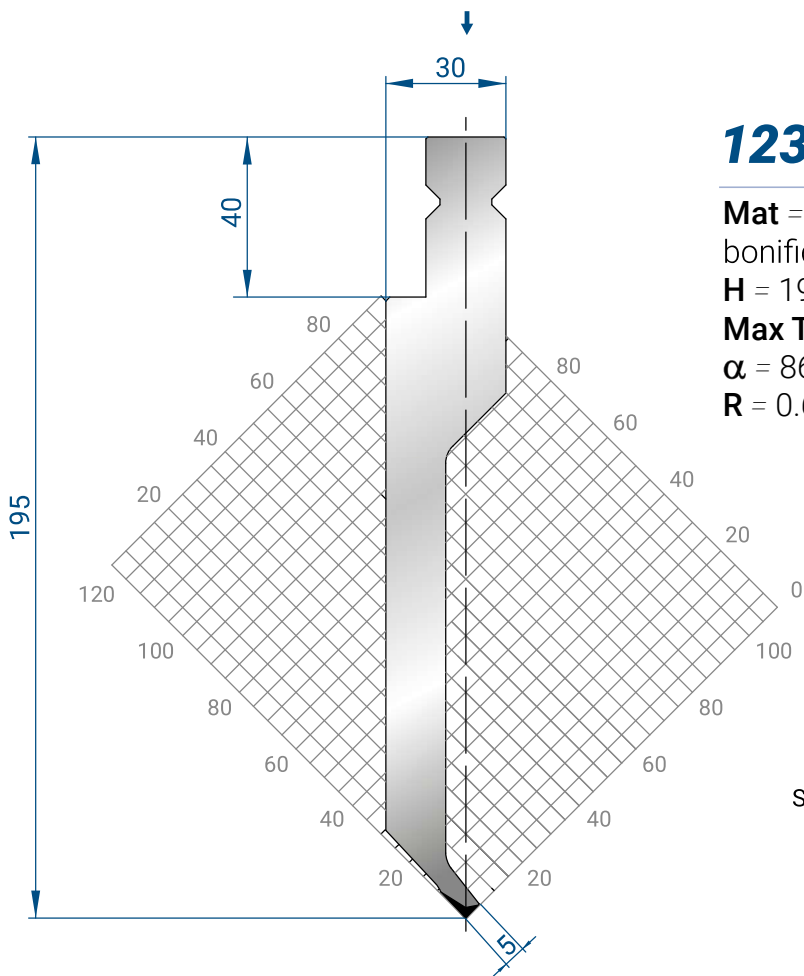

## 1234

**Mat** = 42CrMo4  
 bonificato / *tempered*  
**H** = 195.00  
**Max T/m** = 30  
 $\alpha$  = 86°  
**R** = 0.6

500 mm	13,3 kg
300 mm	8,0 kg
200 mm	5,3 kg
100 mm	2,7 kg
550 mm FRAZ. /SECT	13,1 kg
100 mm SCARP/ HORN	1,9 kg
50 mm	1,3 kg
45 mm	1,2 kg
40 mm	1,1 kg
35 mm	0,9 kg
30 mm	0,8 kg
25 mm	0,7 kg

(↓)  
 SPINTA IN TESTA  
 HEAD LOAD

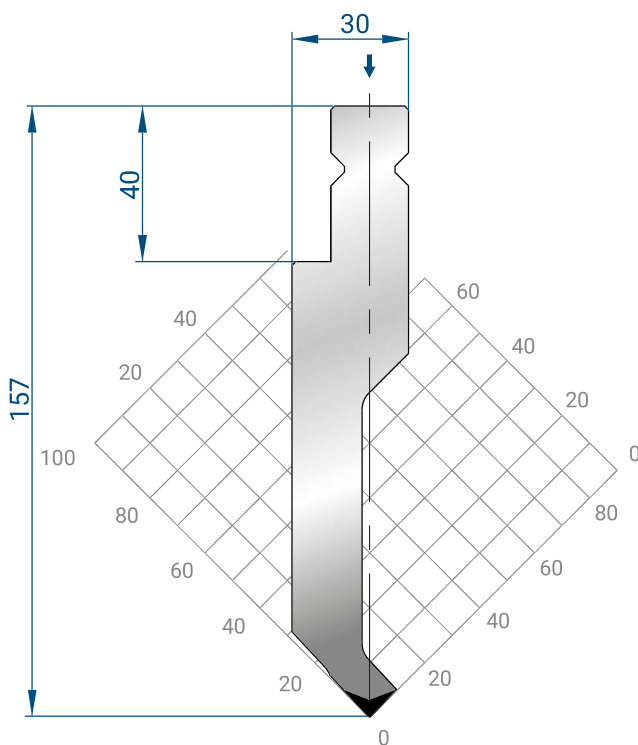

## 1317

**Mat** = 42CrMo4  
 bonificato / *tempered*  
**H** = 157.00  
**Max T/m** = 100  
 $\alpha$  = 86°  
**R** = 1

500 mm	12,1 kg
300 mm	7,3 kg
200 mm	4,8 kg
100 mm	2,4 kg
550 mm FRAZ. /SECT.	11,9 kg
100 mm SCARP/ HORN	1,8 kg
50 mm	1,2 kg
45 mm	1,1 kg
40 mm	1,0 kg
35 mm	0,8 kg
30 mm	0,7 kg
25 mm	0,6 kg

(↓)  
 SPINTA IN TESTA  
 HEAD LOAD

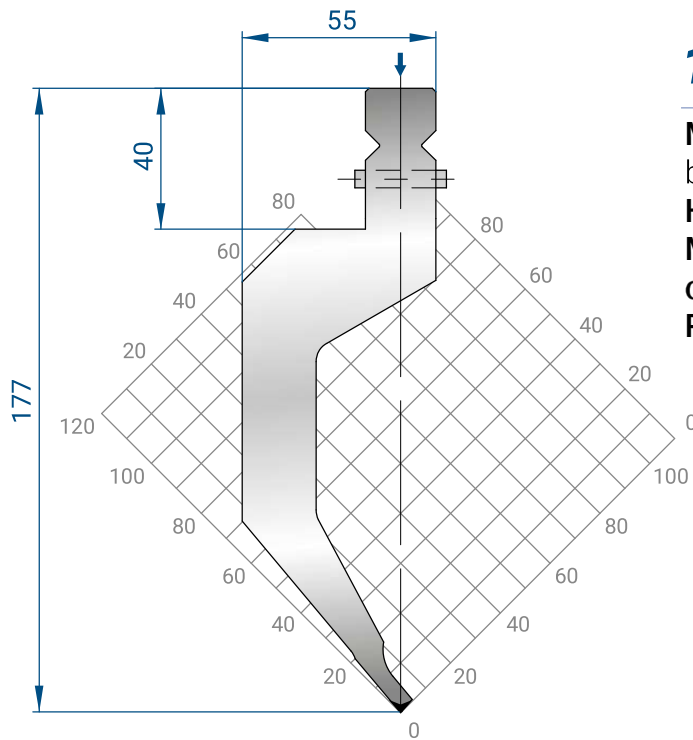

**1319**

**Mat** = 42CrMo4  
 bonificato / *tempered*  
**H** = 177.00  
**Max T/m** = 40  
 $\alpha$  = 80°  
**R** = 0.5

500 mm	15,4 kg
300 mm	9,2 kg
200 mm	6,2 kg
100 mm	3,1 kg
550 mm FRAZ. /SECT.	15,1 kg
100 mm SCARP. /HORN	2,2 kg
50 mm	1,5 kg
45 mm	1,4 kg
40 mm	1,2 kg
35 mm	1,1 kg
30 mm	0,9 kg
25 mm	0,8 kg

↓  
 SPINTA IN TESTA  
 HEAD LOAD

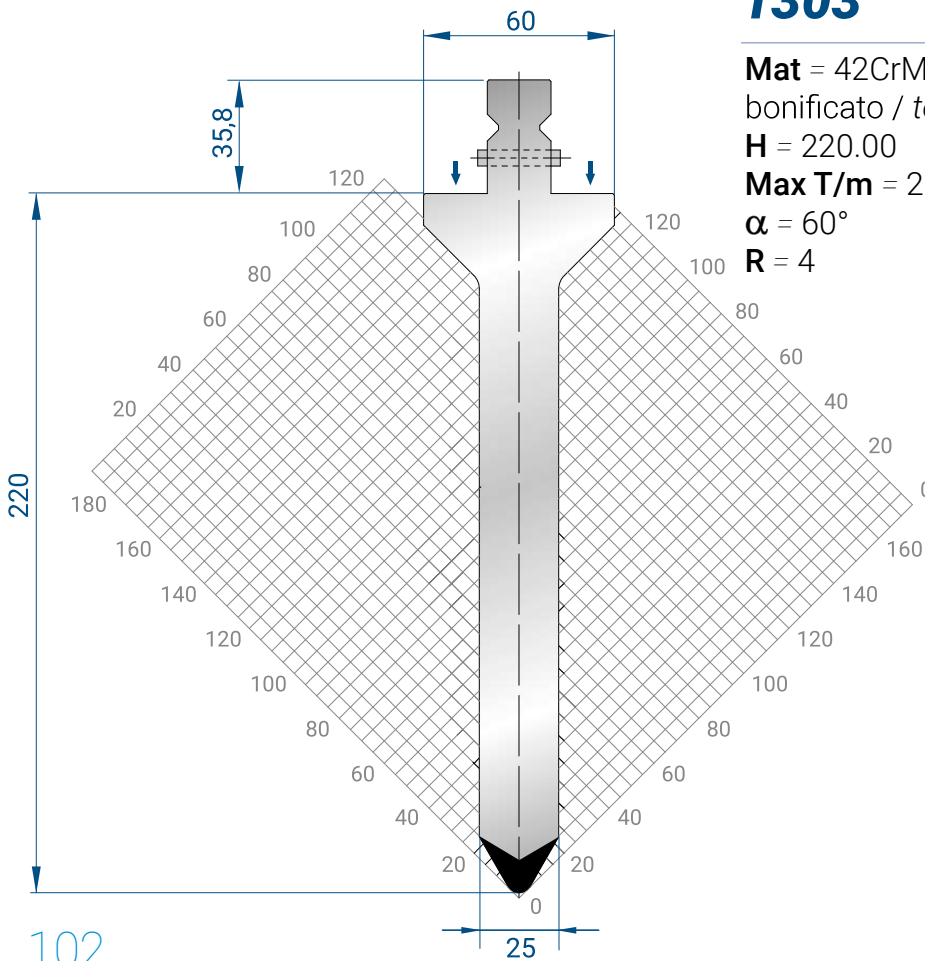

**1303**

**Mat** = 42CrMo4  
 bonificato / *tempered*  
**H** = 220.00  
**Max T/m** = 250  
 $\alpha$  = 60°  
**R** = 4

500 mm	26,1 kg
300 mm	15,6 kg
200 mm	10,4 kg
100 mm	5,2 kg
550 mm FRAZ. /SECT	25,6 kg
100 mm SCARP. /HORN	3,7 kg
50 mm	2,6 kg
45 mm	2,3 kg
40 mm	2,1 kg
35 mm	1,8 kg
30 mm	1,6 kg
25 mm	1,3 kg

↓  
 SPINTA LATERALE  
 SHOULDER LOAD

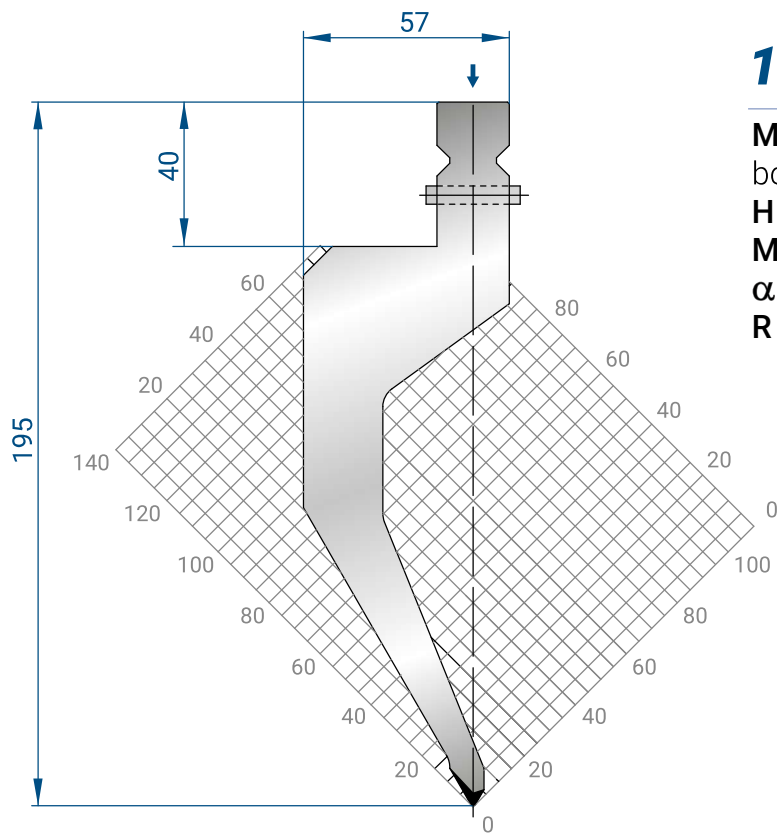

## 1236

**Mat** = 42CrMo4  
 bonificato / *tempered*  
**H** = 195.00  
**Max T/m** = 40  
 $\alpha$  = 60°  
**R** = 0.8

500 mm	17,4 kg
300 mm	10,4 kg
200 mm	7,0 kg
100 mm	3,5 kg
550 mm FRAZ. /SECT	17,1 kg
100 mm SCARP. /HORN	2,4 kg
50 mm	1,7 kg
45 mm	1,6 kg
40 mm	1,4 kg
35 mm	1,2 kg
30 mm	1,0 kg
25 mm	0,9kg

↓  
 SPINTA IN TESTA  
 HEAD LOAD

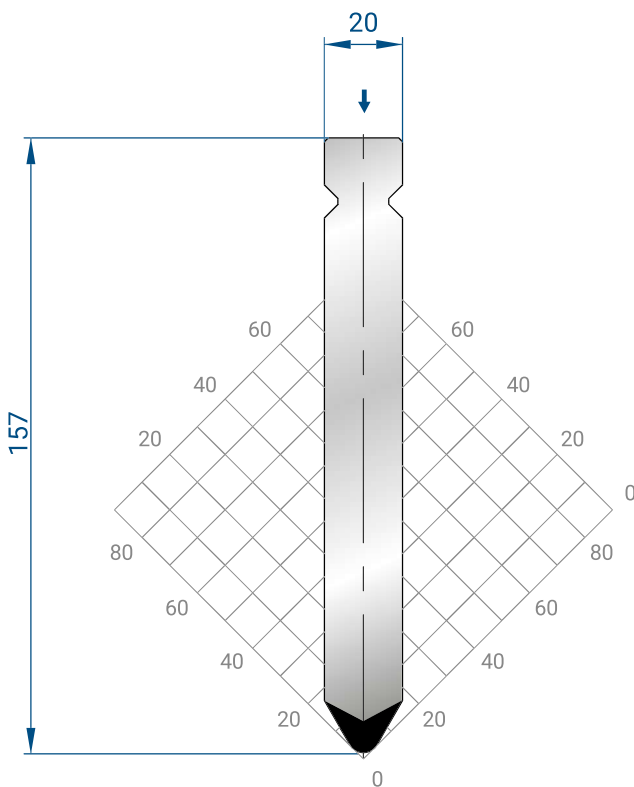

## 1318

**Mat** = 42CrMo4  
 bonificato / *tempered*  
**H** = 157.00  
**Max T/m** = 180  
 $\alpha$  = 60°  
**R** = 4

500 mm	11,8 kg
300 mm	7,0 kg
200 mm	4,7 kg
100 mm	2,4 kg
550 mm FRAZ. /SECT	11,6 kg
100 mm SCARP. /HORN	1,7 kg
50 mm	1,2 kg
45 mm	1,1 kg
40 mm	0,9 kg
35 mm	0,8 kg
30 mm	0,7 kg
25 mm	0,6 kg

↓  
 SPINTA IN TESTA  
 HEAD LOAD

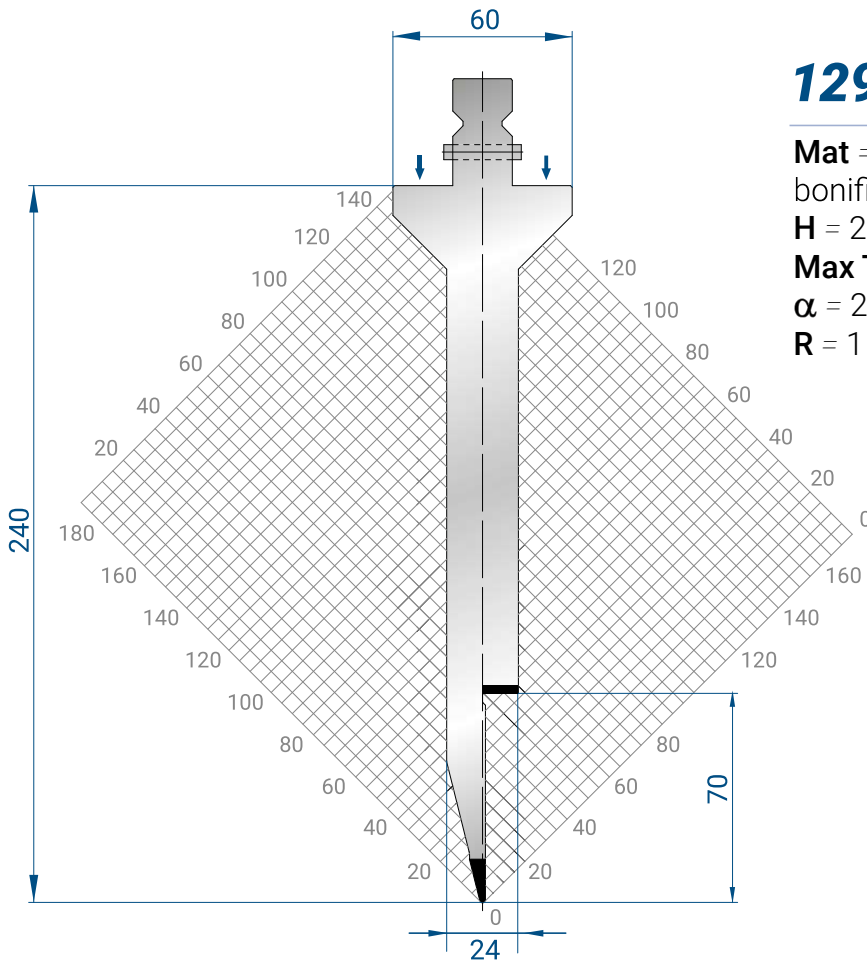

## 1295

Mat = 42CrMo4  
 bonificato / tempered  
 H = 240.00  
 Max T/m = 40  
 $\alpha = 28^\circ$   
 R = 1

500 mm	23,8 kg
300 mm	14,3 kg
200 mm	9,5 kg
100 mm	4,8 kg
550 mm	23,3 kg
FRAZ. /SECT	
100 mm	3,3 kg
SCARP. /HORN	
50 mm	2,4 kg
45 mm	2,1 kg
40 mm	1,9 kg
35 mm	1,7 kg
30 mm	1,4 kg
25 mm	1,2 kg

(↓)  
 SPINTA LATERALE  
 SHOULDER LOAD

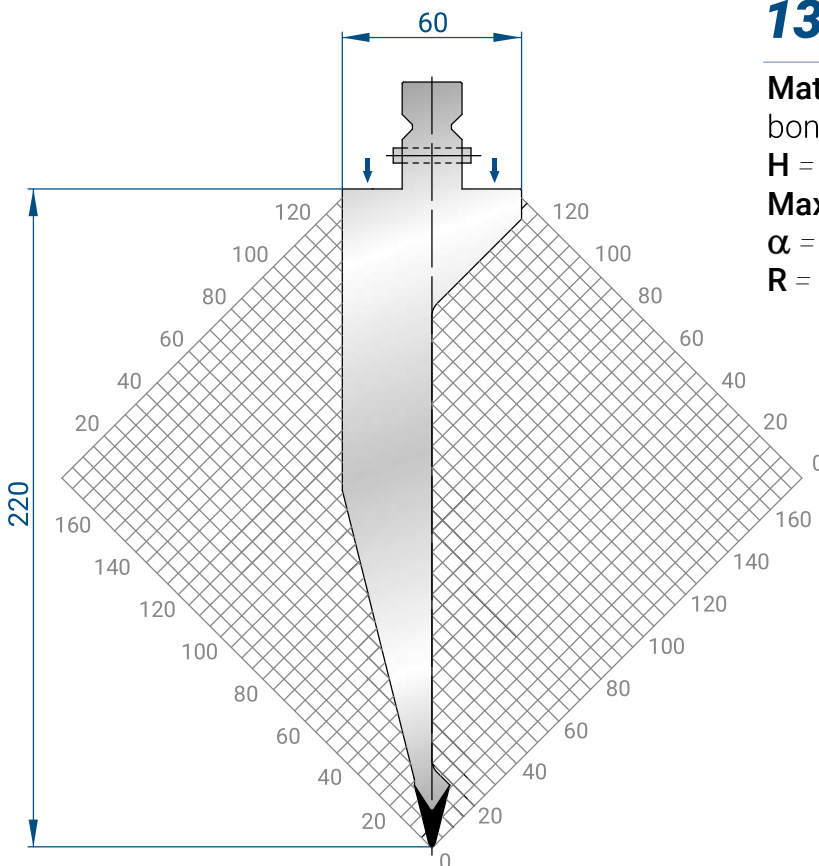

## 1302

Mat = 42CrMo4  
 bonificato / tempered  
 H = 220.00  
 Max T/m = 80  
 $\alpha = 28^\circ$   
 R = 1

500 mm	24,9 kg
300 mm	14,9 kg
200 mm	10,0 kg
100 mm	5,0 kg
550 mm	24,4 kg
FRAZ. /SECT.	
100 mm	3,5 kg
SCARP. /HORN	
50 mm	2,5 kg
45 mm	2,2 kg
40 mm	2,0 kg
35 mm	1,7 kg
30 mm	1,5 kg
25 mm	1,3 kg

(↓)  
 SPINTA LATERALE  
 SHOULDER LOAD

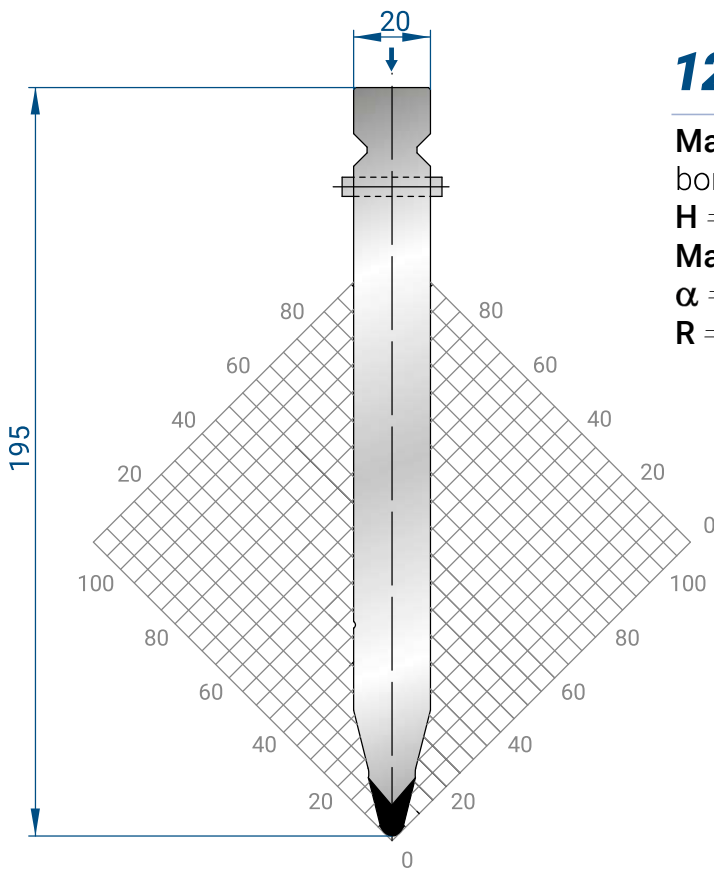

## 1237

**Mat** = 42CrMo4  
 bonificato / *tempered*  
**H** = 195.00  
**Max T/m** = 160  
 $\alpha$  = 28°  
**R** = 3

500 mm	14,1 kg
300 mm	8,5 kg
200 mm	5,7 kg
100 mm	2,8 kg
550 mm FRAZ. /SECT.	13,9 kg
100 mm SCARP. /HORN	2,0 kg
50 mm	1,4 kg
45 mm	1,3 kg
40 mm	1,1 kg
35 mm	1,0 kg
30 mm	0,8 kg
25 mm	0,7 kg

↓  
 SPINTA IN TESTA  
 HEAD LOAD

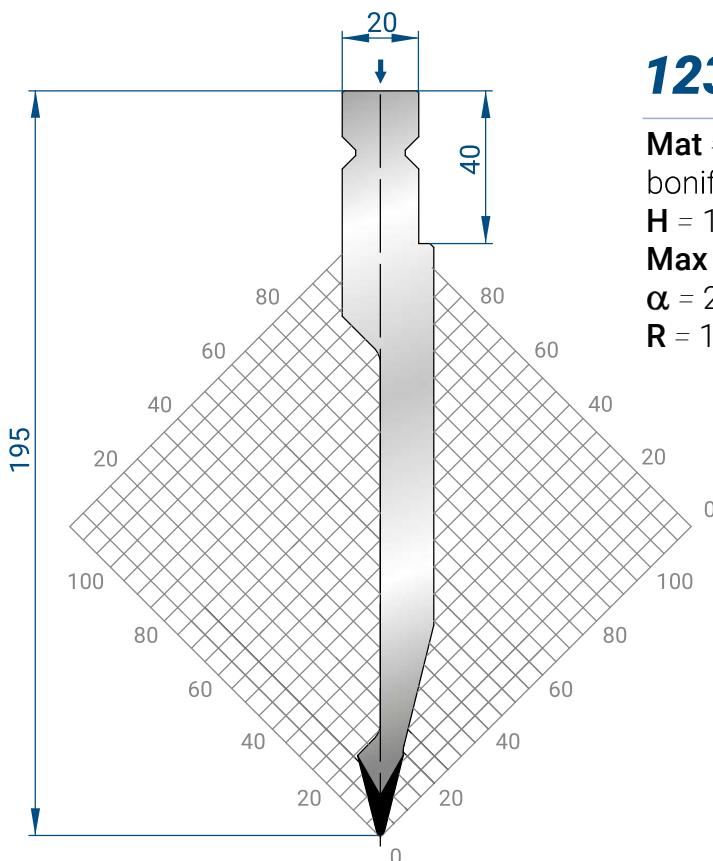

## 1238

**Mat** = 42CrMo4  
 bonificato / *tempered*  
**H** = 195.00  
**Max T/m** = 80  
 $\alpha$  = 28°  
**R** = 1

500 mm	11,4 kg
300 mm	6,8 kg
200 mm	4,5 kg
100 mm	2,3 kg
550 mm FRAZ. /SECT.	11,1 kg
100 mm SCARP. /HORN	1,6 kg
50 mm	1,1 kg
45 mm	1,0 kg
40 mm	0,9 kg
35 mm	0,8 kg
30 mm	0,7 kg
25 mm	0,6 kg

↓  
 SPINTA IN TESTA  
 HEAD LOAD

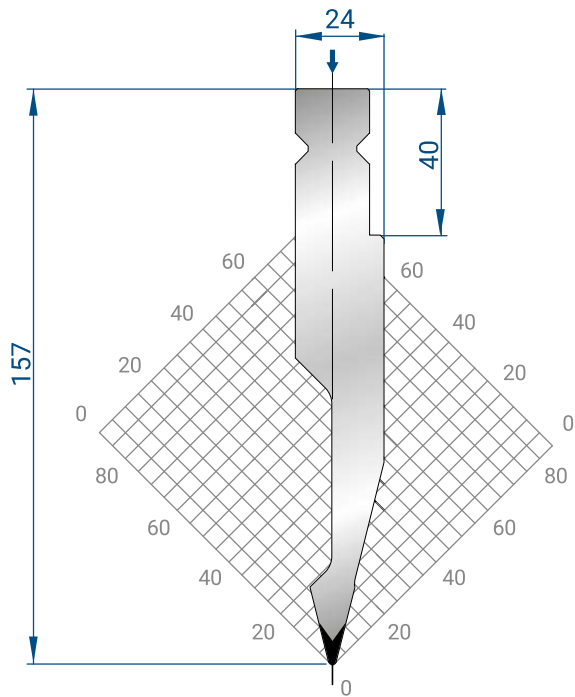

### 1313

**Mat** = 42CrMo4  
 bonificato / *tempered*  
**H** = 157.00  
**Max T/m** = 80  
 $\alpha$  = 28°  
**R** = 1

500 mm	9,8 kg
300 mm	5,9 kg
200 mm	3,9 kg
100 mm	2,0 kg
550 mm FRAZ. /SECT.	9,7 kg
100 mm SCARP. /HORN	1,4 kg
50 mm	1,0 kg
45 mm	0,9 kg
40 mm	0,8 kg
35 mm	0,7 kg
30 mm	0,6 kg
25mm	0,5 kg

(↓)  
 SPINTA IN TESTA  
 HEAD LOAD

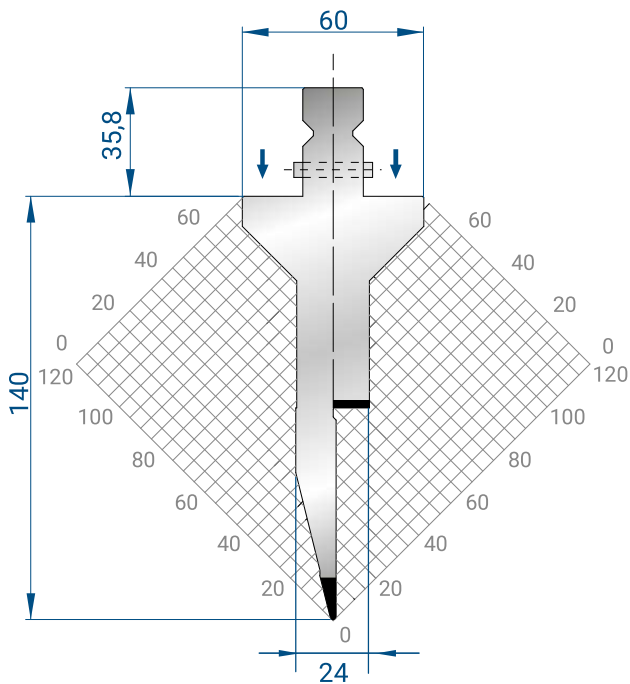

### 1308

**Mat** = 42CrMo4  
 bonificato / *tempered*  
**H** = 140.00  
**Max T/m** = 40  
 $\alpha$  = 28°  
**R** = 1

500 mm	14,4 kg
300 mm	8,7 kg
200 mm	5,8 kg
100 mm	2,9 kg
550 mm FRAZ. /SECT.	14,1 kg
100 mm SCARP. /HORN	2,0 kg
50 mm	1,4 kg
45 mm	1,3 kg
40 mm	1,2 kg
35 mm	1,0 kg
30 mm	0,9 kg
25 mm	0,7 kg

(↓)  
 SPINTA LATERALE  
 SHOULDER LOAD

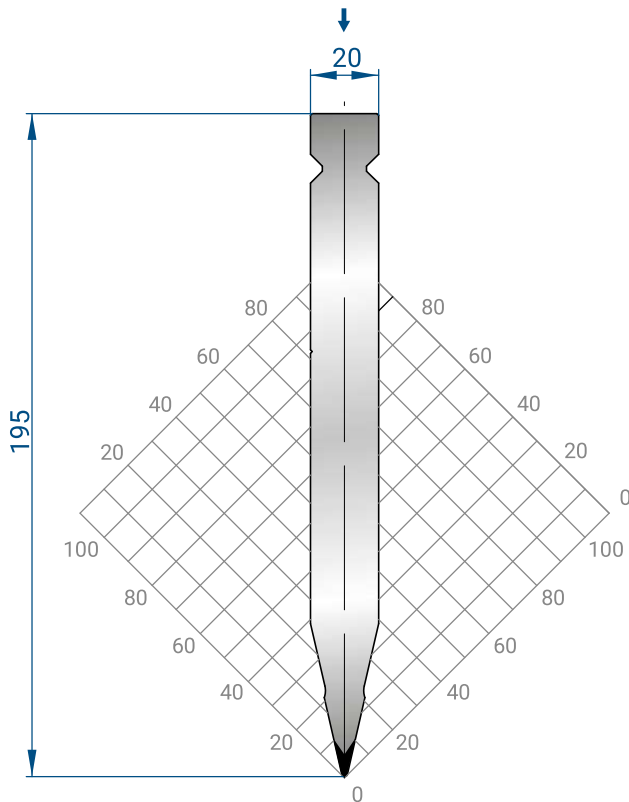

## 1316

**Mat** = 42CrMo4  
 bonificato / *tempered*  
**H** = 195.00  
**Max T/m** = 100  
 $\alpha$  = 26°  
**R** = 0.8

500 mm	13,5 kg
300 mm	8,1 kg
200 mm	5,4 kg
100 mm	2,7 kg
550 mm FRAZ. /SECT.	13,2 kg
100 mm SCARP. /HORN	1,9 kg
50 mm	1,4 kg
45 mm	1,2 kg
40 mm	1,1 kg
35 mm	0,9 kg
30 mm	0,8 kg
25 mm	0,7 kg

(↓)  
 SPINTA IN TESTA  
 HEAD LOAD

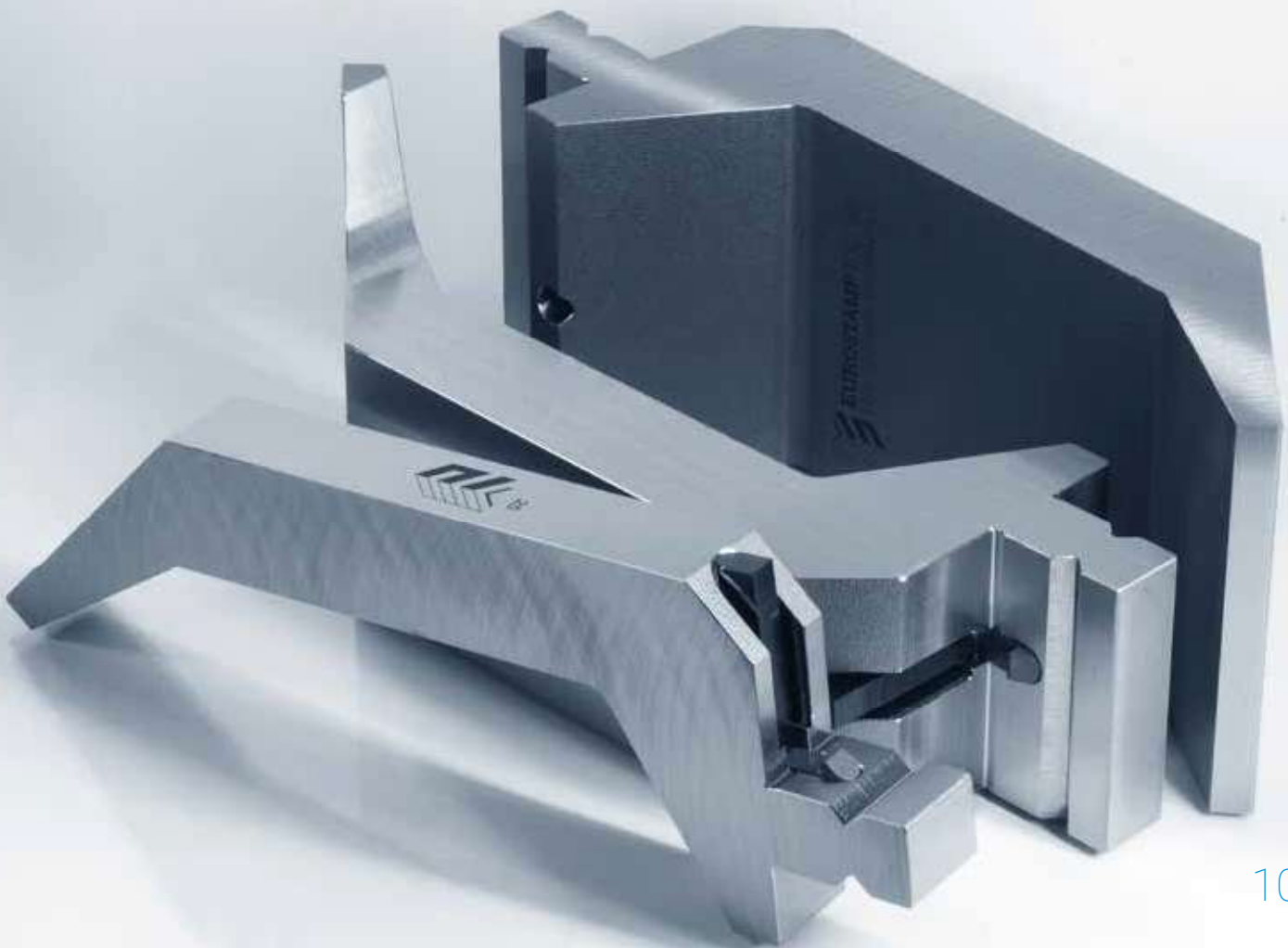

## 8210

FRESATURA PULSANTE  
MILLING FOR SAFETY BUTTON

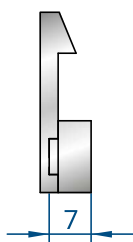

## 8211

CODICI /  
CODES  
1237-1240-  
1316-1318

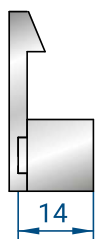

## 8218

CODICI /  
CODES  
1238-1249-  
1250-1251-  
1313

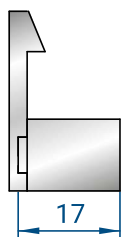

## 8212

CODICI /  
CODES  
1234-1235-  
1317-4191

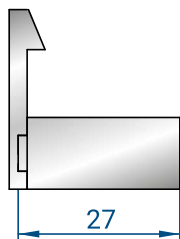

## 8213

CODICI /  
CODES  
1295-1302-  
1303-1308-  
4361

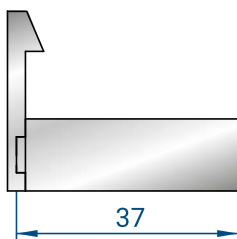

## 8214

CODICI /  
CODES  
1233-1314-  
1319

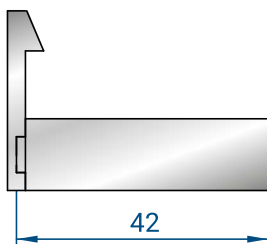

## 8215

CODICI /  
CODES  
1236

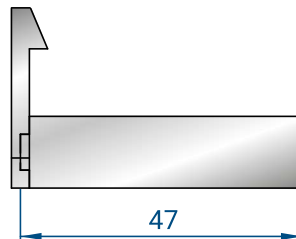

## 8216

CODICI /  
CODES  
1294-1320

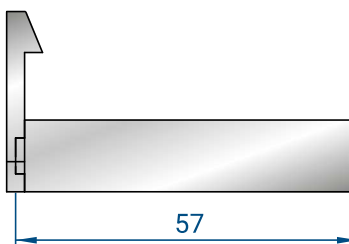

## 8219

CODICI /  
CODES  
1315



## 8204

VITE PER SAFETY PUSH BUTTON  
SCREW FOR SAFETY PUSH BUTTON

## 8206

GANCETTO PER SAFETY PUSH BUTTON  
HOOK FOR SAFETY PUSH BUTTON

## 8207

MOLLA PER SAFETY PUSH BUTTON  
SPRING FOR SAFETY PUSH BUTTON



TRUMPF STYLE



**EUROSTAMP TOOLING**  
the Italian excellence

**3244**

A 84°  
R 1.6  
H 100

V 14  
L 200  
90 T/m

25



25

40



VEDI PAG. 92 PER SCHEMA FRAZIONATURA PUNZONI  
SEE PAGE 92 FOR PUNCHES SEGMENTATION DIAGRAM

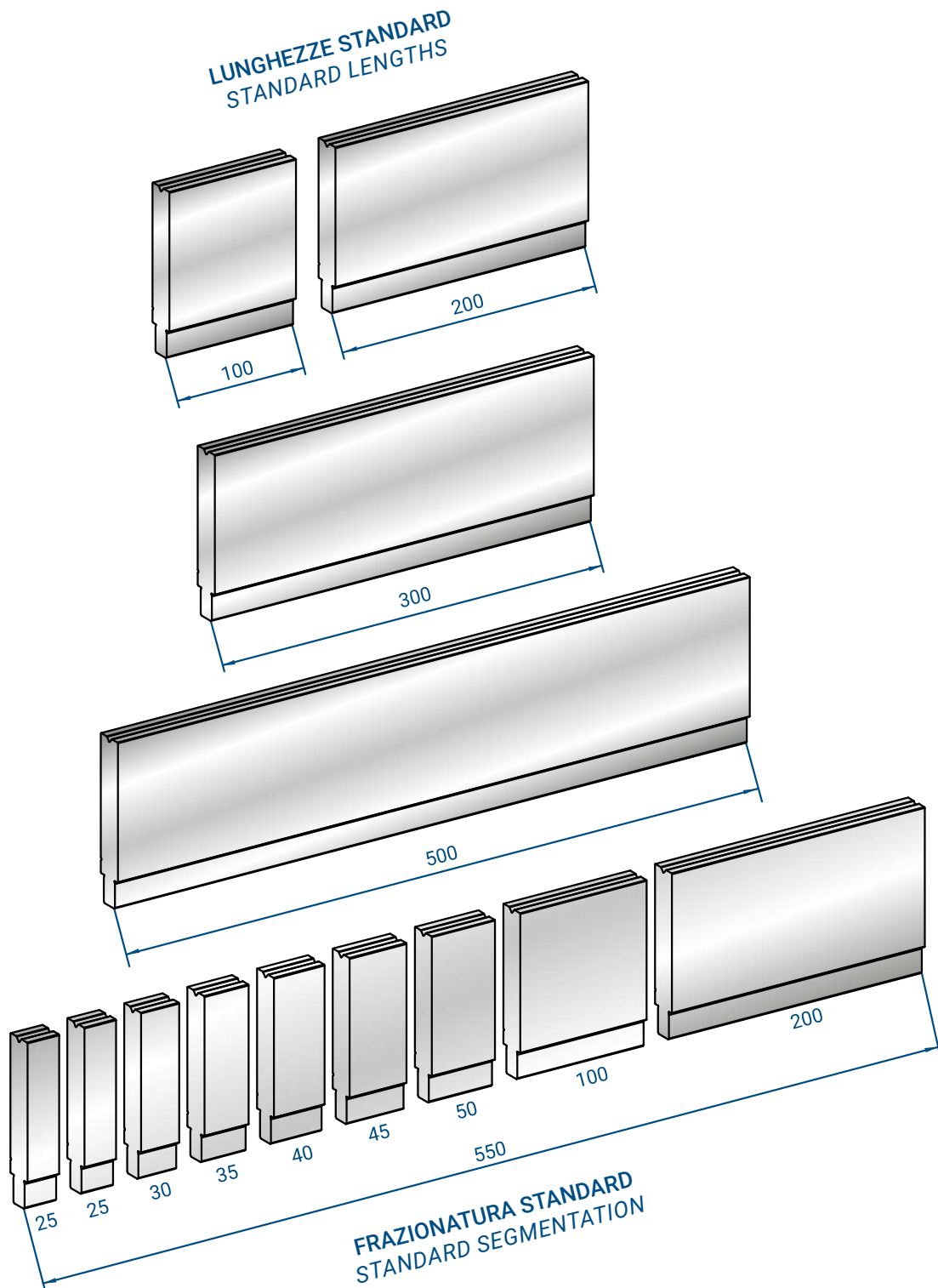

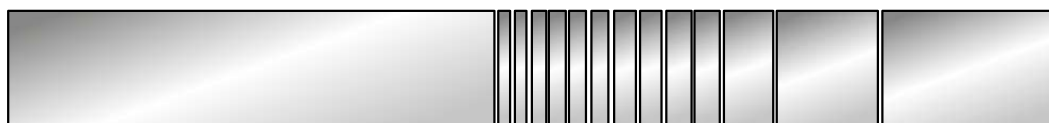

**TAGLI SU RICHIESTA**  
**SPECIAL SEGMENTATION**

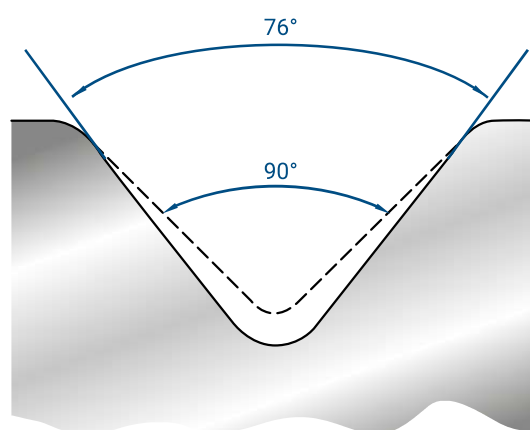



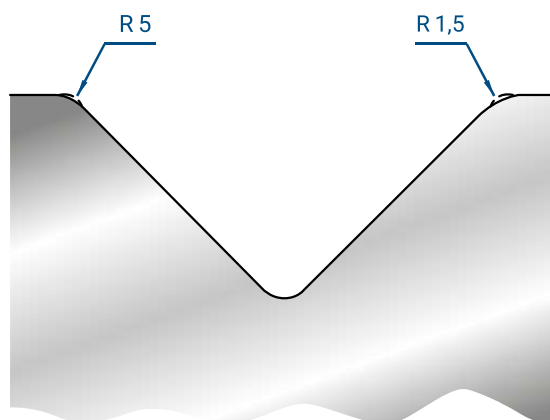









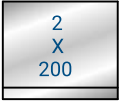
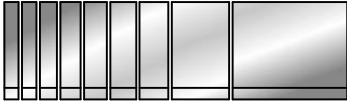

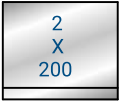
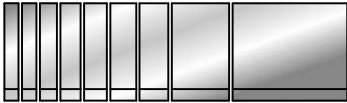
**MODIFICA ANGOLO**  
**ANGLE MODIFICATION**

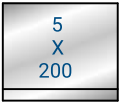

**MODIFICA RAGGIO**  
**RADIUS MODIFICATION**

FRAZIONATURE PER MATRICI MODELLO  
SEGMENTATION FOR DIE MODELS

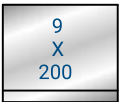
**3135 - 3222**  
**3223 - 3224**

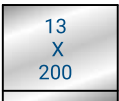









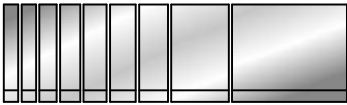







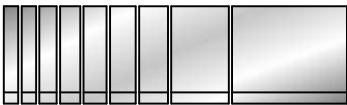

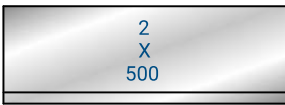

550			
1050			
1250			
2050			
2550			
3050			
4050			

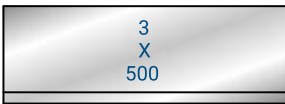
FRAZIONATURE PER MATRICI MODELLO  
SEGMENTATION FOR DIE MODELS

**3218 - 3219 - 3220 -  
3221 - 3132 - 3133 - 3134**

550				
1050				
1250				
2050				
2550				
3050				
4050				

FRAZIONATURE PER TUTTI GLI ALTRI MODELLI  
SEGMENTATION FOR OTHER DIE MODELS

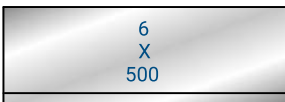
550				
1050				
1250				
2050				
2550				
3050				
4050				

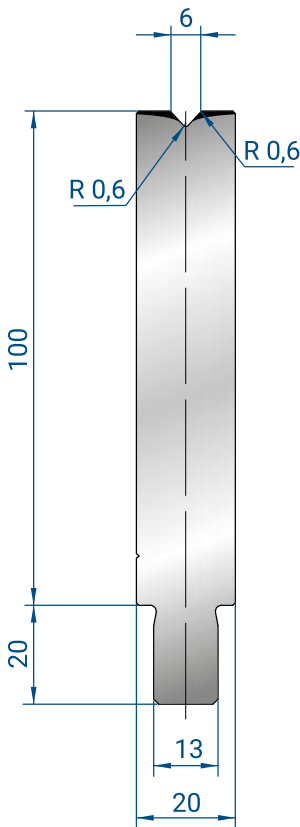

500 mm	8,8 kg
300 mm	5,3 kg
200 mm	3,6 kg
100 mm	1,8 kg
550 mm	9,7 kg
FRAZ. /SECT.	
50 mm	0,9 kg
45 mm	0,8 kg
40 mm	0,7 kg
35 mm	0,6 kg
30 mm	0,5 kg
25 mm	0,4 kg

### 3200

**Mat** = 42CrMo4  
 bonificato /  
 tempered  
**Max T/m** = 100  
 $\alpha = 86^\circ$

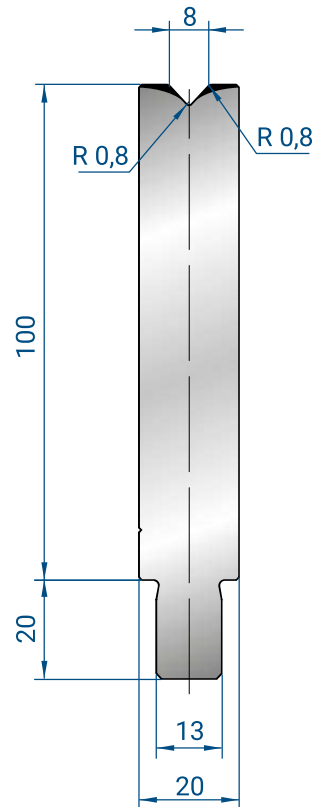

500 mm	8,8 kg
300 mm	5,3 kg
200 mm	3,5 kg
100 mm	1,8 kg
550 mm	9,6 kg
FRAZ. /SECT.	
50 mm	0,9 kg
45 mm	0,8 kg
40 mm	0,7 kg
35 mm	0,6 kg
30 mm	0,5 kg
25 mm	0,4 kg

### 3201

**Mat** = 42CrMo4  
 bonificato /  
 tempered  
**Max T/m** = 100  
 $\alpha = 86^\circ$

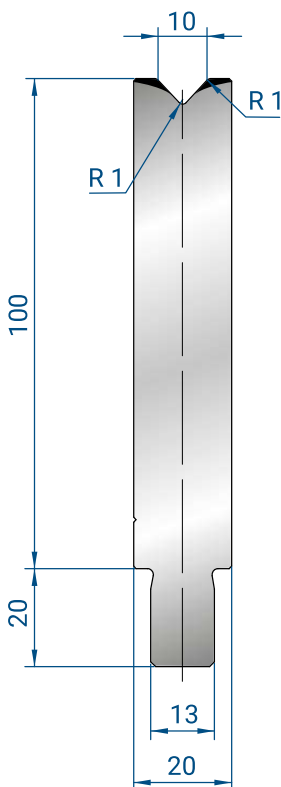

500 mm	8,7 kg
300 mm	5,2 kg
200 mm	3,5 kg
100 mm	1,7 kg
550 mm	9,6 kg
FRAZ. /SECT.	
50 mm	0,9 kg
45 mm	0,8 kg
40 mm	0,7 kg
35 mm	0,6 kg
30 mm	0,5 kg
25 mm	0,4 kg

### 3202

**Mat** = 42CrMo4  
 bonificato /  
 tempered  
**Max T/m** = 100  
 $\alpha = 86^\circ$

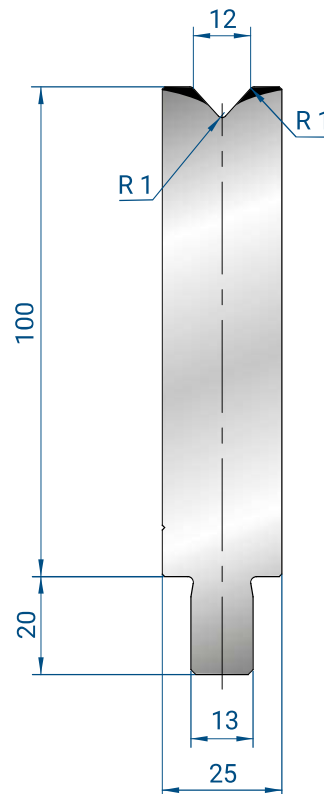

500 mm	10,6 kg
300 mm	6,4 kg
200 mm	4,3 kg
100 mm	2,1 kg
550 mm	11,7 kg
FRAZ. /SECT.	
50 mm	1,1 kg
45 mm	1,0 kg
40 mm	0,9 kg
35 mm	0,7 kg
30 mm	0,6 kg
25 mm	0,5 kg

### 3203

**Mat** = 42CrMo4  
 bonificato /  
 tempered  
**Max T/m** = 100  
 $\alpha = 86^\circ$

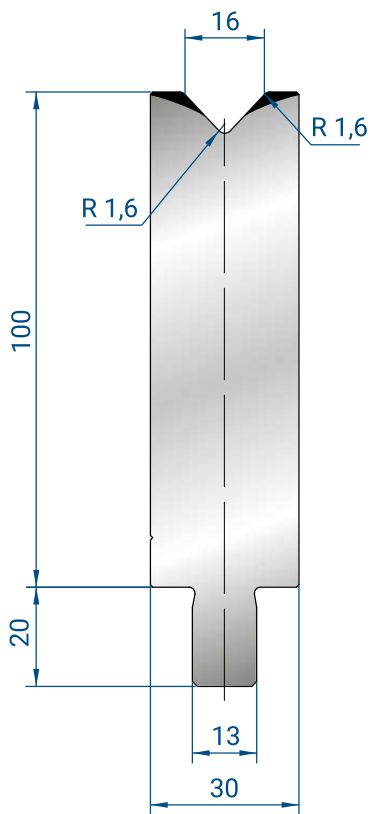

500 mm	12,5 kg
300 mm	7,5 kg
200 mm	5,0 kg
100 mm	2,5 kg
550 mm	13,7 kg
FRAZ. /SECT.	
50 mm	1,3 kg
45 mm	1,1 kg
40 mm	1,0 kg
35 mm	0,9 kg
30 mm	0,8 kg
25 mm	0,6 kg

### 3204

Mat = 42CrMo4  
 bonificato /  
 tempered  
 Max T/m = 100  
 $\alpha = 86^\circ$

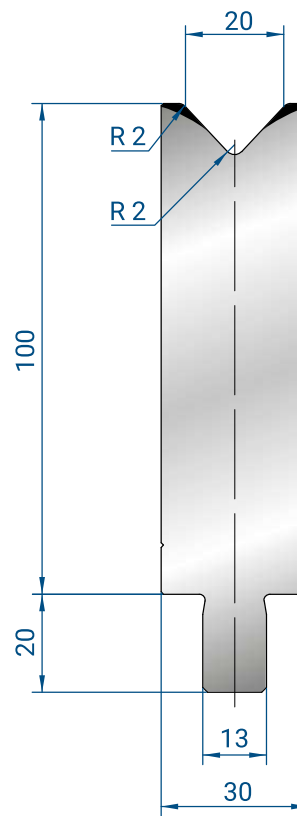

500 mm	12,3 kg
300 mm	7,4 kg
200 mm	4,9 kg
100 mm	2,5 kg
550 mm	13,5 kg
FRAZ. /SECT.	
50 mm	1,2 kg
45 mm	1,1 kg
40 mm	1,0 kg
35 mm	0,9 kg
30 mm	0,7 kg
25 mm	0,6 kg

### 3205

Mat = 42CrMo4  
 bonificato /  
 tempered  
 Max T/m = 100  
 $\alpha = 86^\circ$

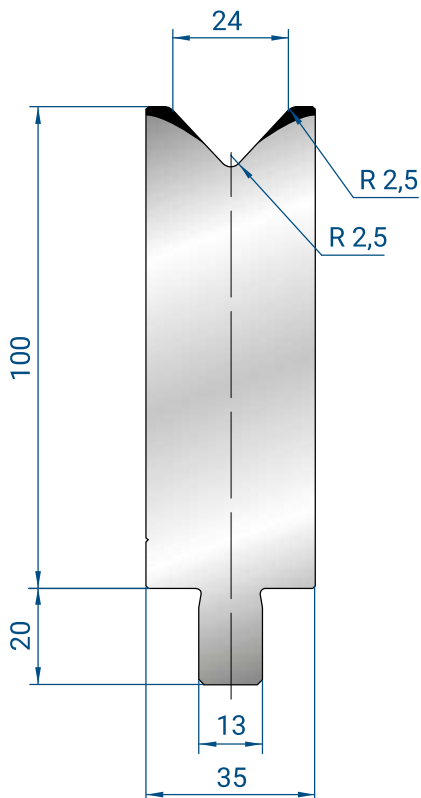

500 mm	14,0 kg
300 mm	8,4 kg
200 mm	5,6 kg
100 mm	2,8 kg
550 mm	15,4 kg
FRAZ. /SECT.	
50 mm	1,4 kg
45 mm	1,3 kg
40 mm	1,1 kg
35 mm	1,0 kg
30 mm	0,8 kg
25 mm	0,7 kg

### 3215

Mat = 42CrMo4  
 bonificato /  
 tempered  
 Max T/m = 100  
 $\alpha = 86^\circ$

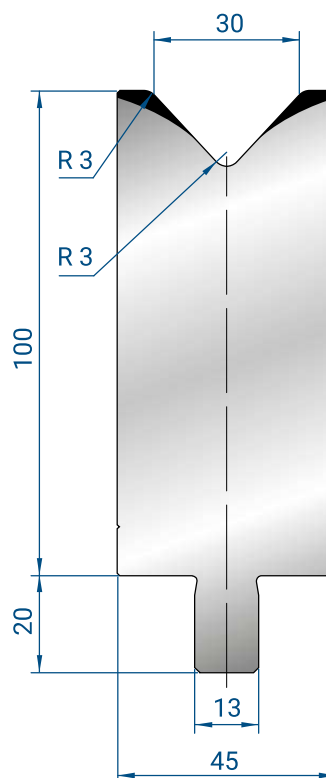

500 mm	17,6 kg
300 mm	10,5 kg
200 mm	7,0 kg
100 mm	3,5 kg
550 mm	19,3 kg
FRAZ. /SECT.	
50 mm	1,8 kg
45 mm	1,6 kg
40 mm	1,4 kg
35 mm	1,2 kg
30 mm	1,0 kg
25 mm	0,9 kg

### 3216

Mat = 42CrMo4  
 bonificato /  
 tempered  
 Max T/m = 100  
 $\alpha = 86^\circ$

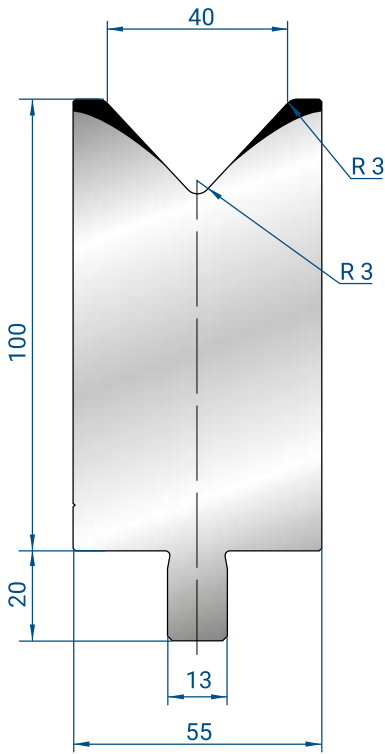

500 mm	20,7 kg
300 mm	12,4 kg
200 mm	8,3 kg
100 mm	4,1 kg
550 mm FRAZ. /SECT.	22,8 kg
50 mm	2,1 kg
45 mm	1,9 kg
40 mm	1,7 kg
35 mm	1,5 kg
30 mm	1,2 kg
25 mm	1,0 kg

### 3217

**Mat** = 42CrMo4  
bonificato /  
tempered  
**Max T/m** = 120  
 $\alpha$  = 86°

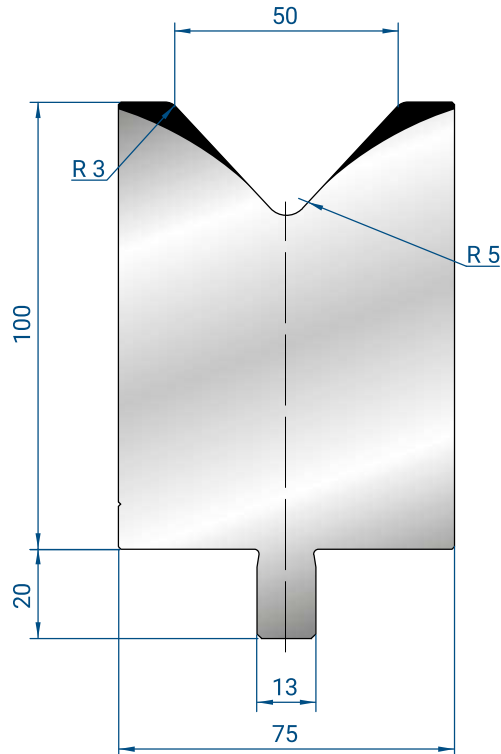

500 mm	27,6 kg
300 mm	16,6 kg
200 mm	11,0 kg
100 mm	5,5 kg
550 mm FRAZ. /SECT.	30,3 kg
50 mm	2,8 kg
45 mm	2,5 kg
40 mm	2,2 kg
35 mm	1,9 kg
30 mm	1,7 kg
25 mm	1,4 kg

### 3218

**Mat** = 42CrMo4  
bonificato /  
tempered  
**Max T/m** = 150  
 $\alpha$  = 86°

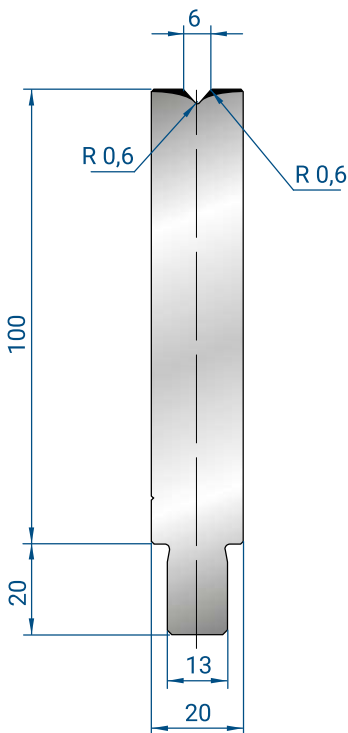

500 mm	8,8 kg
300 mm	5,3 kg
200 mm	3,5 kg
100 mm	1,8 kg
550 mm FRAZ. /SECT.	9,7 kg
50 mm	0,9 kg
45 mm	0,8 kg
40 mm	0,7 kg
35 mm	0,6 kg
30 mm	0,5 kg
25 mm	0,4 kg

### 3225

**Mat** = 42CrMo4  
bonificato /  
tempered  
**Max T/m** = 100  
 $\alpha$  = 84°

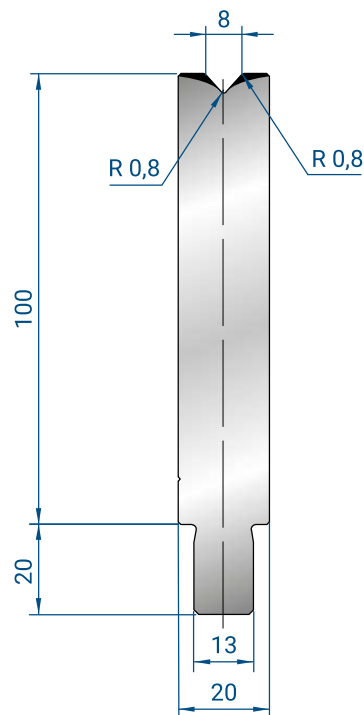

500 mm	8,8 kg
300 mm	5,3 kg
200 mm	3,5 kg
100 mm	1,8 kg
550 mm FRAZ. /SECT.	9,7 kg
50 mm	0,9 kg
45 mm	0,8 kg
40 mm	0,7 kg
35 mm	0,6 kg
30 mm	0,5 kg
25 mm	0,4 kg

### 3226

**Mat** = 42CrMo4  
bonificato /  
tempered  
**Max T/m** = 100  
 $\alpha$  = 84°

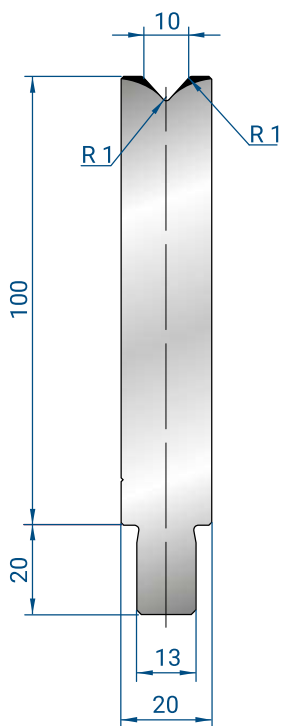

500 mm	8,7 kg
300 mm	5,2 kg
200 mm	3,5 kg
100 mm	1,7 kg
550 mm FRAZ. /SECT.	9,6 kg
50 mm	0,9 kg
45 mm	0,8 kg
40 mm	0,7 kg
35 mm	0,6 kg
30 mm	0,5 kg
25 mm	0,4 kg

### 3227

**Mat** = 42CrMo4  
bonificato /  
tempered  
**Max T/m** = 100  
 $\alpha$  = 84°

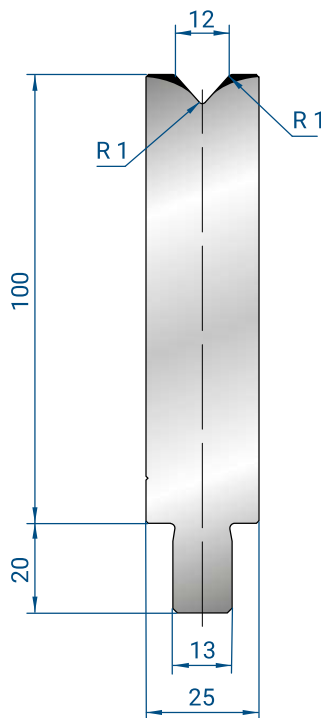

500 mm	10,6 kg
300 mm	6,4 kg
200 mm	4,2 kg
100 mm	2,1 kg
550 mm FRAZ. /SECT.	11,7 kg
50 mm	1,1 kg
45 mm	1,0 kg
40 mm	0,8 kg
35 mm	0,7 kg
30 mm	0,6 kg
25 mm	0,5 kg

### 3228

**Mat** = 42CrMo4  
bonificato /  
tempered  
**Max T/m** = 100  
 $\alpha$  = 84°

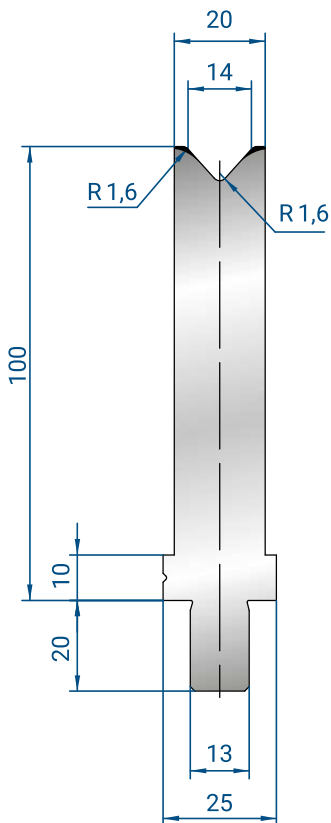

500 mm	8,8 kg
300 mm	5,3 kg
200 mm	3,5 kg
100 mm	1,8 kg
550 mm FRAZ. /SECT.	9,7 kg
50 mm	0,9 kg
45 mm	0,8 kg
40 mm	0,7 kg
35 mm	0,6 kg
30 mm	0,5 kg
25 mm	0,4 kg

### 3244

**Mat** = 42CrMo4  
bonificato /  
tempered  
**Max T/m** = 90  
 $\alpha$  = 84°

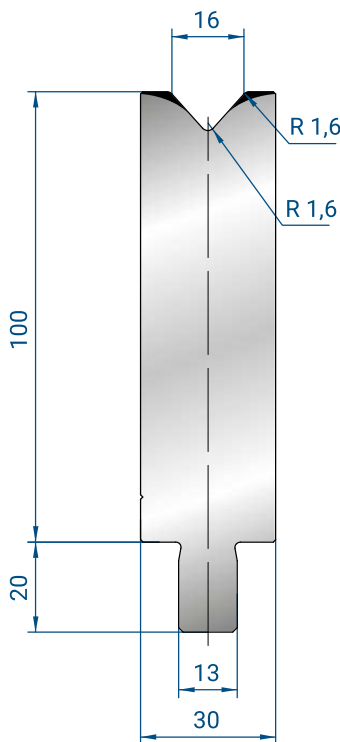

500 mm	12,4 kg
300 mm	7,5 kg
200 mm	5,0 kg
100 mm	2,5 kg
550 mm FRAZ. /SECT.	13,7 kg
50 mm	1,2 kg
45 mm	1,1 kg
40 mm	1,0 kg
35 mm	0,9 kg
30 mm	0,7 kg
25 mm	0,6 kg

### 3229

**Mat** = 42CrMo4  
bonificato /  
tempered  
**Max T/m** = 100  
 $\alpha$  = 84°

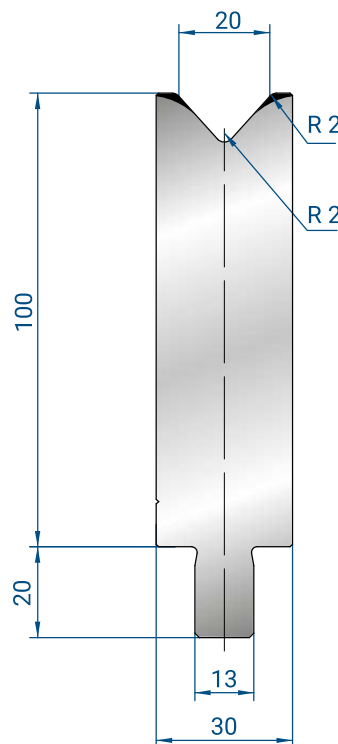

500 mm	12,3 kg
300 mm	7,4 kg
200 mm	4,9 kg
100 mm	2,5 kg
550 mm	13,5 kg
FRAZ. /SECT.	
50 mm	1,2 kg
45 mm	1,1 kg
40 mm	1,0 kg
35 mm	0,9 kg
30 mm	0,7 kg
25 mm	0,6 kg

### 3230

**Mat** = 42CrMo4  
 bonificato /  
 tempered  
**Max T/m** = 100  
 $\alpha$  = 84°

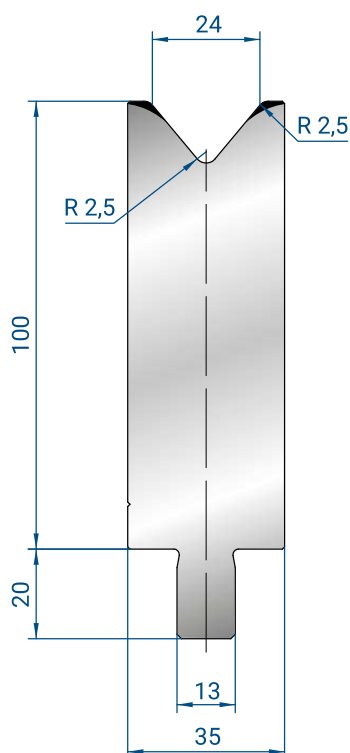

500 mm	14,0 kg
300 mm	8,4 kg
200 mm	5,6 kg
100 mm	2,8 kg
550 mm	15,4 kg
FRAZ. /SECT.	
50 mm	1,4 kg
45 mm	1,3 kg
40 mm	1,1 kg
35 mm	1,0 kg
30 mm	0,8 kg
25 mm	0,7 kg

### 3231

**Mat** = 42CrMo4  
 bonificato /  
 tempered  
**Max T/m** = 100  
 $\alpha$  = 80°

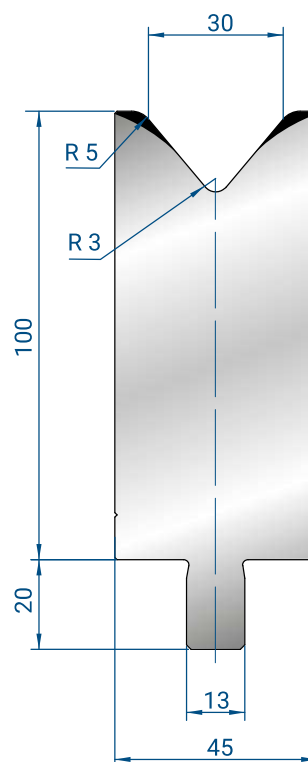

500 mm	17,4 kg
300 mm	10,9 kg
200 mm	6,9 kg
100 mm	3,5 kg
550 mm	19,1 kg
FRAZ. /SECT.	
50 mm	1,7 kg
45 mm	1,6 kg
40 mm	1,4 kg
35 mm	1,2 kg
30 mm	1,0 kg
25 mm	0,9 kg

### 3232

**Mat** = 42CrMo4  
 bonificato /  
 tempered  
**Max T/m** = 120  
 $\alpha$  = 80°

### 3233

**Mat** = 42CrMo4  
 bonificato /  
 tempered  
**Max T/m** = 150  
 $\alpha = 80^\circ$

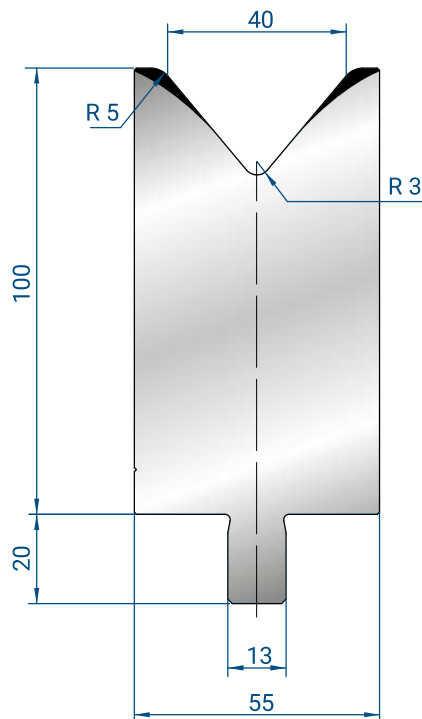

500 mm	20,4 kg
300 mm	12,2 kg
200 mm	8,2 kg
100 mm	14,1 kg
550 mm FRAZ. /SECT.	22,4 kg
50 mm	2,0 kg
45 mm	1,8 kg
40 mm	1,6 kg
35 mm	1,4 kg
30 mm	1,2 kg
25 mm	1,0 kg

### 3234

**Mat** = 42CrMo4  
 bonificato /  
 tempered  
**Max T/m** = 150  
 $\alpha = 80^\circ$

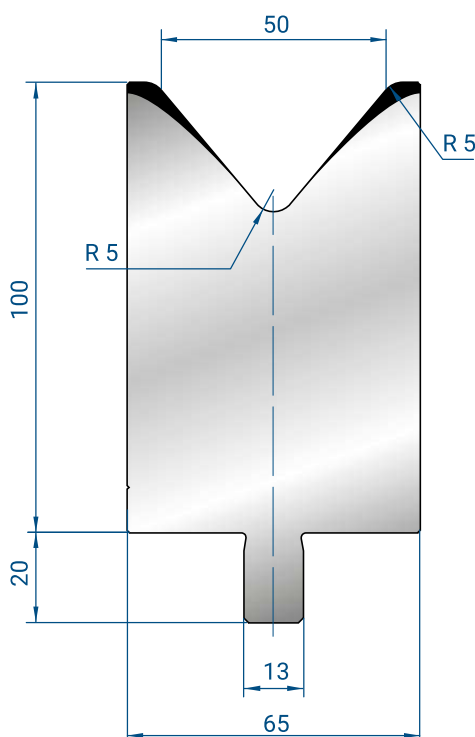

500 mm	23,2 kg
300 mm	13,9 kg
200 mm	9,3 kg
100 mm	4,6 kg
550 mm FRAZ. /SECT.	25,5 kg
50 mm	2,3 kg
45 mm	2,1 kg
40 mm	1,9 kg
35 mm	1,6 kg
30 mm	1,4 kg
25 mm	1,2 kg

### 3219

**Mat** = 42CrMo4  
 bonificato /  
 tempered  
**Max T/m** = 150  
 $\alpha = 80^\circ$

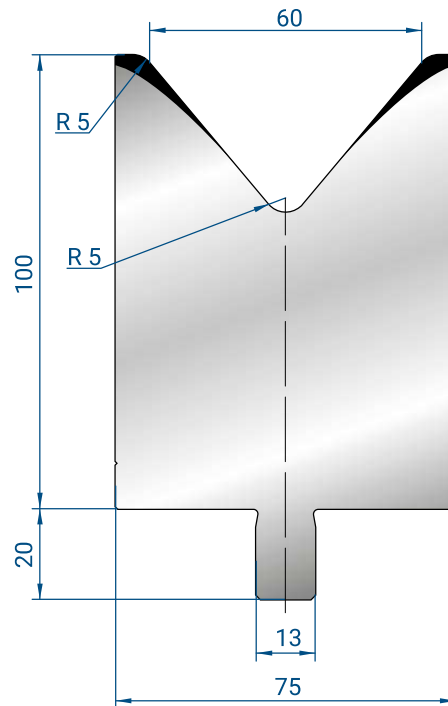

500 mm	25,8 kg
300 mm	14,5 kg
200 mm	10,3 kg
100 mm	5,2 kg
550 mm FRAZ. /SECT.	28,3 kg
50 mm	2,6 kg
45 mm	2,3kg
40 mm	2,1 kg
35 mm	1,8 kg
30 mm	1,5 kg
25 mm	1,3 kg

### 3220

**Mat** = 42CrMo4  
 bonificato /  
 tempered  
**Max T/m** = 150  
 $\alpha = 80^\circ$

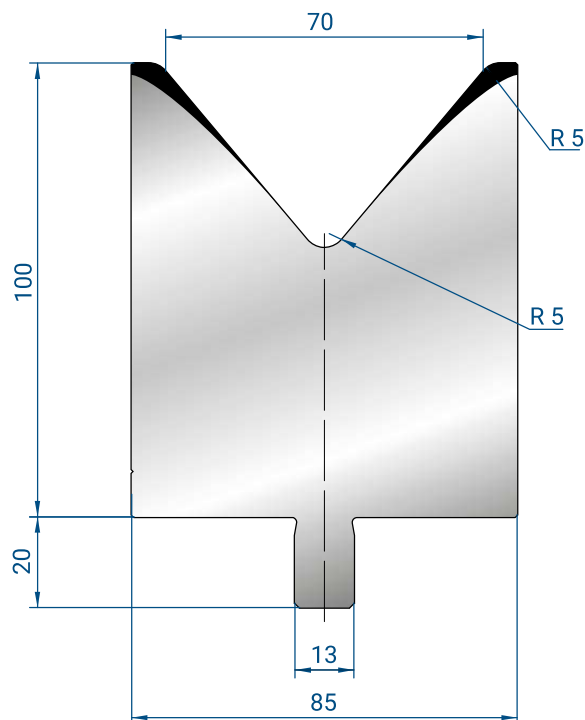

300 mm	16,9 kg
200 mm	11,2 kg
100 mm	5,6 kg
550 mm FRAZ. /SECT.	30,9 kg
50 mm	2,8 kg
45 mm	2,5 kg
40 mm	2,2 kg
35 mm	2,0 kg
30 mm	1,7 kg
25 mm	1,4 kg

### 3221

**Mat** = 42CrMo4  
 bonificato /  
 tempered  
**Max T/m** = 150  
 $\alpha = 80^\circ$

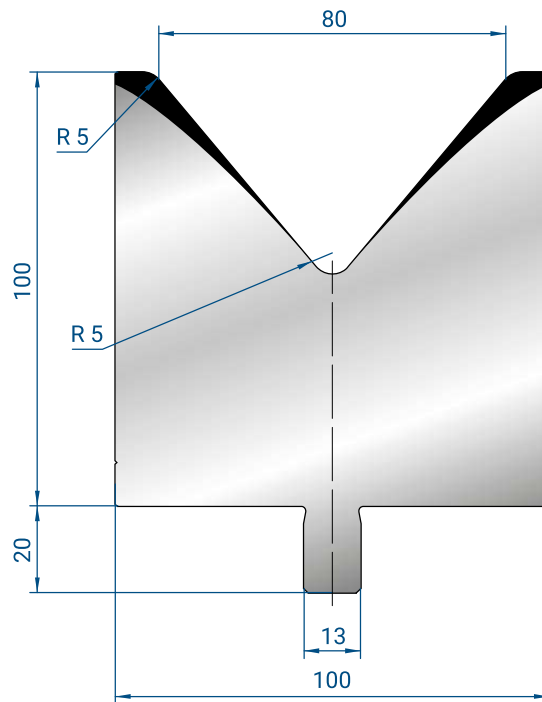

300 mm	19,3 kg
200 mm	12,9 kg
100 mm	6,4 kg
550 mm FRAZ. /SECT.	35,4 kg
50 mm	3,2 kg
45 mm	2,9 kg
40 mm	2,6 kg
30 mm	2,3 kg
25 mm	1,9 kg
25 mm	1,6 kg

### 3222

**Mat** = 42CrMo4  
 bonificato /  
 tempered  
**Max T/m** = 150  
 $\alpha = 80^\circ$

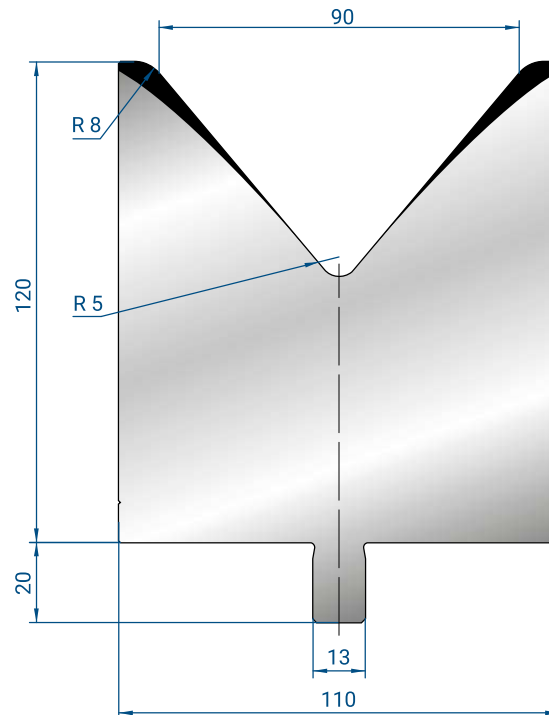

200 mm	16,9 kg
100 mm	8,4 kg
550 mm FRAZ. /SECT.	46,5 kg
50 mm	4,2 kg
45 mm	3,8 kg
40 mm	3,4 kg
35 mm	3,0 kg
30 mm	2,5 kg
25 mm	2,1 kg

### 3223

**Mat** = 42CrMo4  
 bonificato /  
 tempered  
**Max T/m** = 150  
 $\alpha$  = 80°

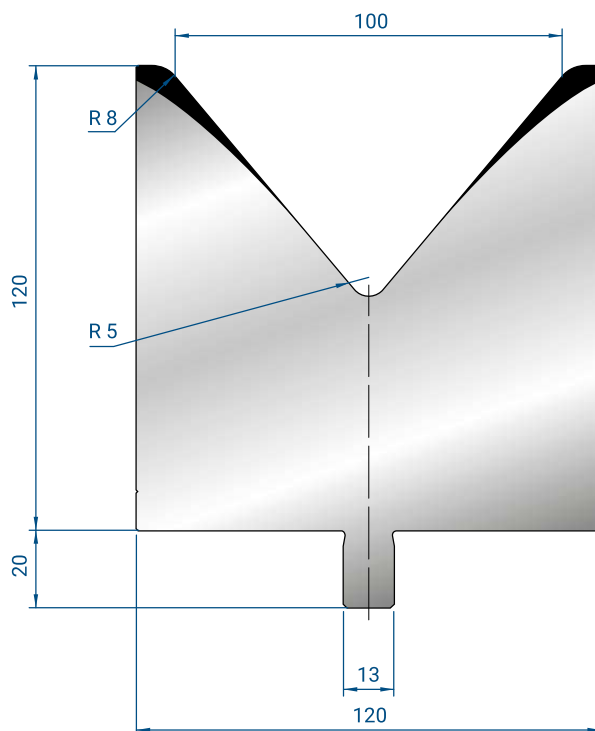

200 mm	17,8 kg
100 mm	8,9 kg
550 mm FRAZ. /SECT	49,1 kg
50 mm	4,5 kg
45 mm	4,0 kg
40 mm	3,6 kg
35 mm	3,1 kg
30 mm	2,7 kg
25 mm	2,2 kg

### 3224

**Mat** = 42CrMo4  
 bonificato /  
 tempered  
**Max T/m** = 160  
 $\alpha$  = 60°

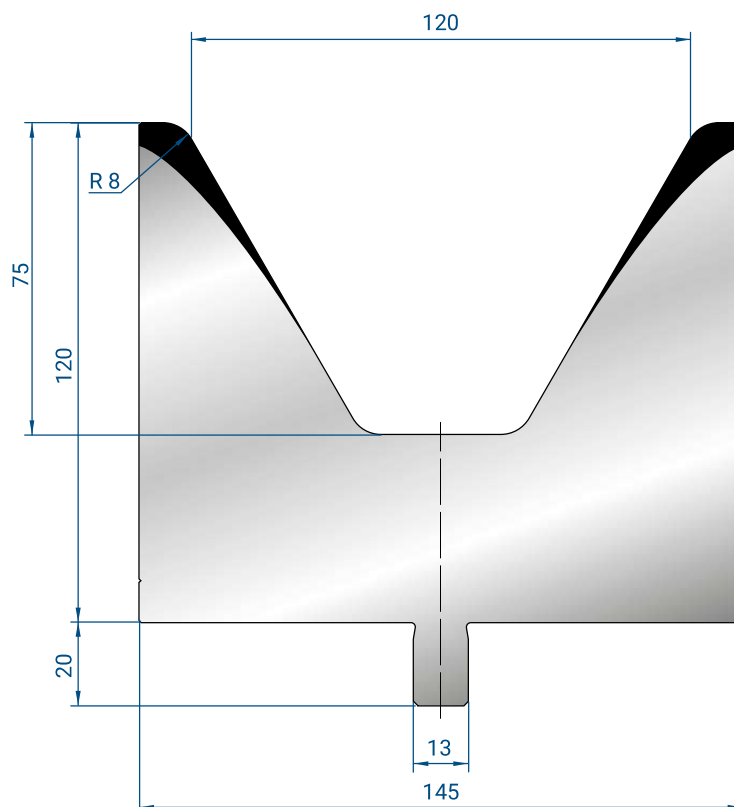

200 mm	18,1 kg
100 mm	9,1 kg
550 mm FRAZ. /SECT	49,8 kg
50 mm	4,5 kg
45 mm	4,1 kg
40 mm	3,6 kg
35 mm	3,2 kg
30 mm	2,7 kg
25 mm	2,3 kg

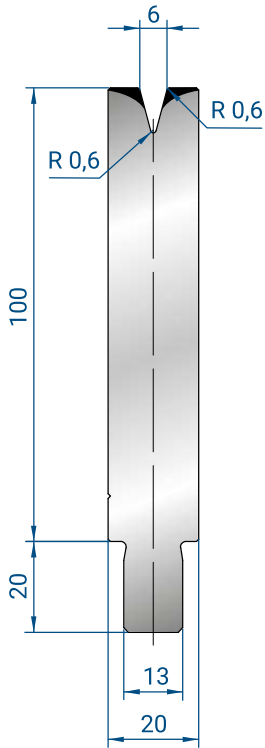

500 mm	8,7 kg
300 mm	5,2 kg
200 mm	3,5 kg
100 mm	1,7 kg
550 mm	9,6 kg
FRAZ. /SECT.	
50 mm	0,9 kg
45 mm	0,8 kg
40 mm	0,7 kg
35 mm	0,6 kg
30 mm	0,5 kg
25 mm	0,4 kg

### 3206

Mat = 42CrMo4  
 bonificato /  
 tempered  
 Max T/m = 60  
 $\alpha = 30^\circ$

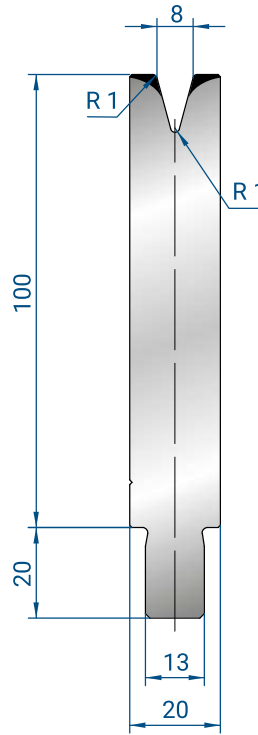

500 mm	8,6 kg
300 mm	5,2 kg
200 mm	3,4 kg
100 mm	1,7 kg
550 mm	9,4 kg
FRAZ. /SECT.	
50 mm	0,9 kg
45 mm	0,8 kg
40 mm	0,7 kg
35 mm	0,6 kg
30 mm	0,5 kg
25 mm	0,4 kg

### 3207

Mat = 42CrMo4  
 bonificato /  
 tempered  
 Max T/m = 50  
 $\alpha = 30^\circ$

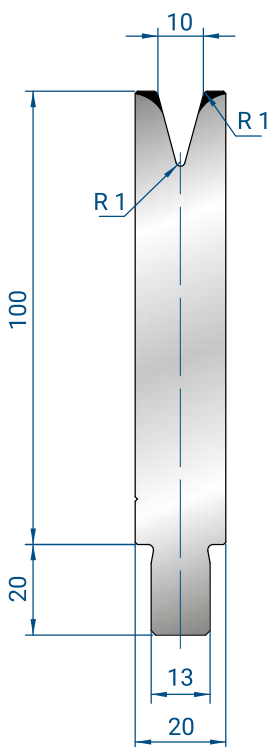

500 mm	8,4 kg
300 mm	5,1 kg
200 mm	3,4 kg
100 mm	1,7 kg
550 mm	9,3 kg
FRAZ. /SECT.	
50 mm	0,8 kg
45 mm	0,8 kg
40 mm	0,7 kg
35 mm	0,6 kg
30 mm	0,5 kg
25 mm	0,4 kg

### 3208

Mat = 42CrMo4  
 bonificato /  
 tempered  
 Max T/m = 50  
 $\alpha = 30^\circ$

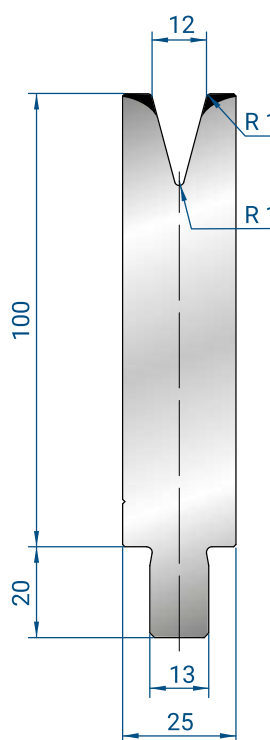

500 mm	10,2 kg
300 mm	6,1 kg
200 mm	4,1 kg
100 mm	2,0 kg
550 mm	11,3 kg
FRAZ. /SECT.	
50 mm	1,0 kg
45 mm	0,9 kg
40 mm	0,8 kg
35 mm	0,7 kg
30 mm	0,6 kg
25 mm	0,5 kg

### 3209

Mat = 42CrMo4  
 bonificato /  
 tempered  
 Max T/m = 56  
 $\alpha = 30^\circ$

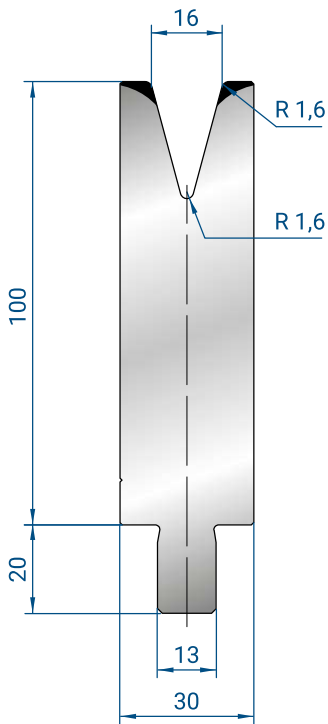

500 mm	11,8 kg
300 mm	7,1 kg
200 mm	4,7 kg
100 mm	2,4 kg
550 mm	12,9 kg
FRAZ. /SECT.	
50 mm	1,2 kg
45 mm	1,1 kg
40 mm	0,9 kg
35 mm	0,8 kg
30 mm	0,7 kg
25 mm	0,6 kg

### 3210

**Mat** = 42CrMo4  
 bonificato /  
 tempered  
**Max T/m** = 68  
 $\alpha$  = 30°

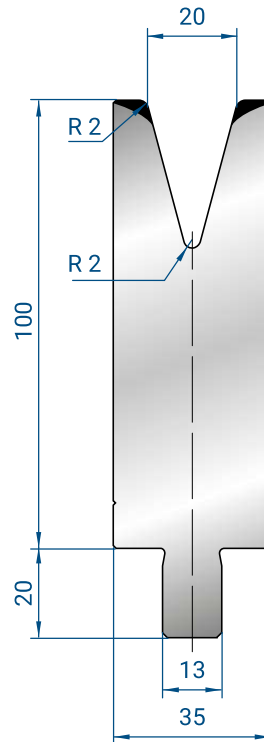

500 mm	13,2 kg
300 mm	7,9 kg
200 mm	5,3 kg
100 mm	2,6 kg
550 mm	14,4 kg
FRAZ. /SECT.	
50 mm	1,3 kg
45 mm	1,2 kg
40 mm	1,1 kg
35 mm	0,9 kg
30 mm	0,8 kg
25 mm	0,7 kg

### 3211

**Mat** = 42CrMo4  
 bonificato /  
 tempered  
**Max T/m** = 50  
 $\alpha$  = 30°

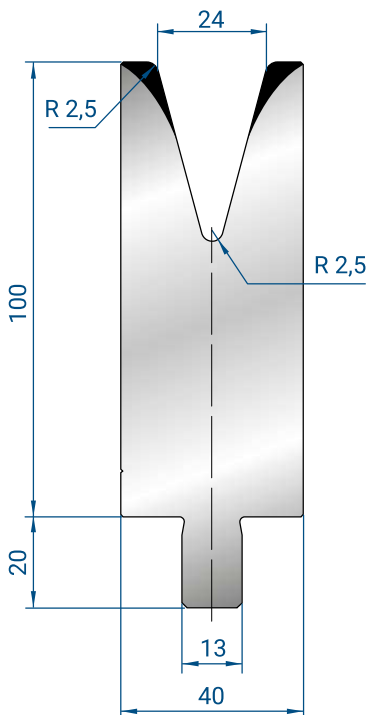

500 mm	14,4 kg
300 mm	8,7 kg
200 mm	5,8 kg
100 mm	2,9 kg
550 mm	15,9 kg
FRAZ. /SECT.	
50 mm	1,4 kg
45 mm	1,3 kg
40 mm	1,2 kg
35 mm	1,0 kg
30 mm	0,9 kg
25 mm	0,7 kg

### 3212

**Mat** = 42CrMo4  
 bonificato /  
 tempered  
**Max T/m** = 55  
 $\alpha$  = 30°

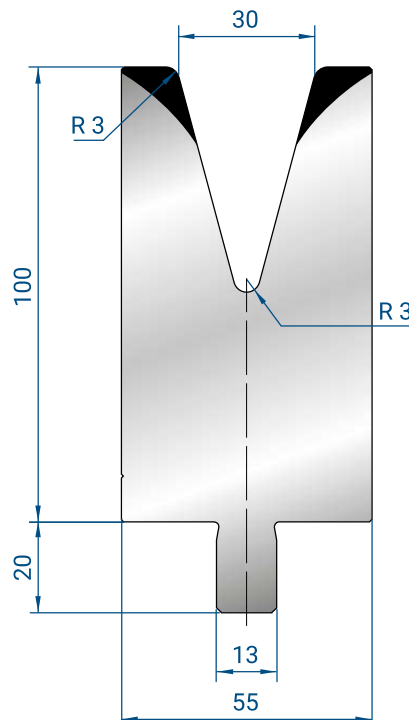

500 mm	19,1 kg
300 mm	11,4 kg
200 mm	7,6 kg
100 mm	3,8 kg
550 mm	21,0 kg
FRAZ. /SECT.	
50 mm	1,9 kg
45 mm	1,7 kg
40 mm	1,5 kg
35 mm	1,3 kg
30 mm	1,1 kg
25 mm	1,0 kg

### 3213

**Mat** = 42CrMo4  
 bonificato /  
 tempered  
**Max T/m** = 85  
 $\alpha$  = 30°

### 3214

**Mat** = 42CrMo4  
 bonificato /  
 tempered  
**Max T/m** = 73  
 $\alpha = 30^\circ$

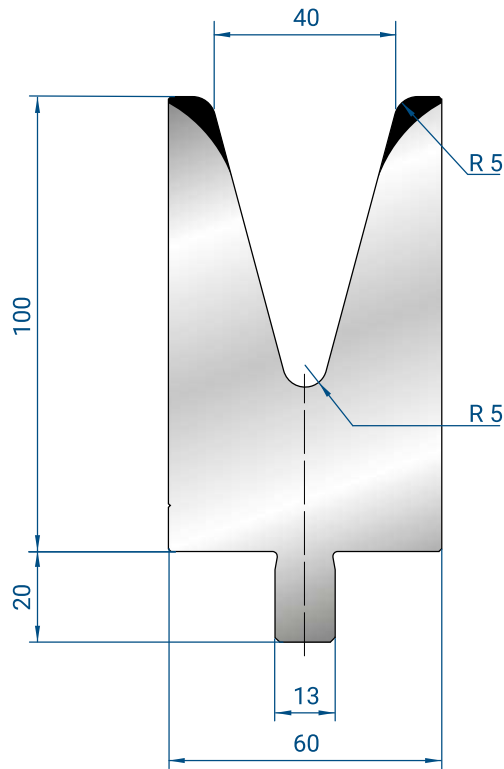

500 mm	18,3 kg
300 mm	11,0 kg
200 mm	7,3 kg
100 mm	3,7 kg
550 mm FRAZ. /SECT	20,1 kg
50 mm	1,8 kg
45 mm	1,6 kg
40 mm	1,5 kg
35 mm	1,3 kg
30 mm	1,1 kg
25 mm	0,9 kg

### 3235

**Mat** = 42CrMo4  
 bonificato /  
 tempered  
**Max T/m** = 100  
 $\alpha = 30^\circ$

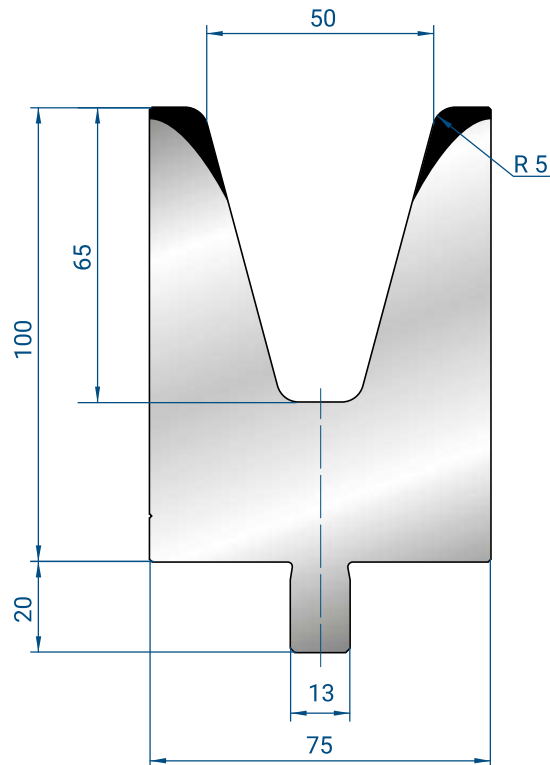

500 mm	21,6 kg
300 mm	12,9 kg
200 mm	8,6 kg
100 mm	4,3 kg
550 mm FRAZ. /SECT	23,7 kg
50 mm	2,2 kg
45 mm	1,9 kg
40 mm	1,7 kg
35 mm	1,5 kg
30 mm	1,3 kg
25 mm	1,1 kg

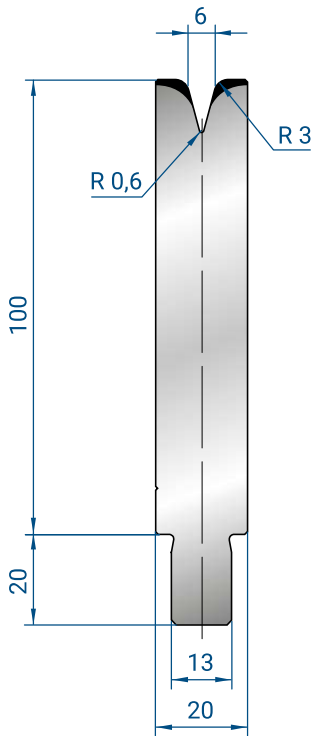

500 mm	8,6 kg
300 mm	5,2 kg
200 mm	3,5 kg
100 mm	1,7 kg
550 mm	9,5 kg
FRAZ. /SECT.	
50 mm	0,9 kg
45 mm	0,8 kg
40 mm	0,7 kg
35 mm	0,6 kg
30 mm	0,5 kg
25 mm	0,4 kg

**3236**

**Mat** = 42CrMo4  
 bonificato /  
 tempered  
**Max T/m** = 45  
 $\alpha = 30^\circ$

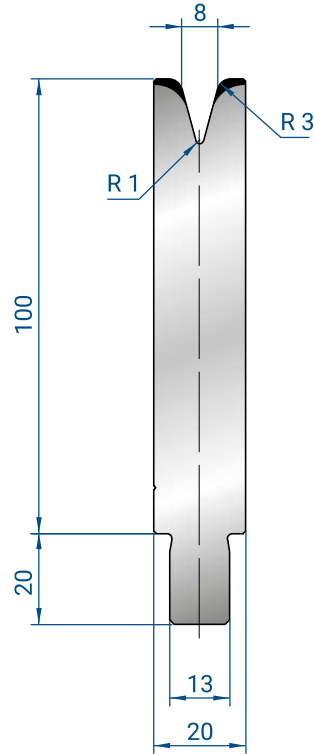

500 mm	8,5 kg
300 mm	5,1 kg
200 mm	3,4 kg
100 mm	1,7 kg
550 mm	9,4 kg
FRAZ. /SECT.	
50 mm	0,9 kg
45 mm	0,8 kg
40 mm	0,7 kg
35 mm	0,6 kg
30 mm	0,5 kg
25 mm	0,4 kg

**3237**

**Mat** = 42CrMo4  
 bonificato /  
 tempered  
**Max T/m** = 40  
 $\alpha = 30^\circ$

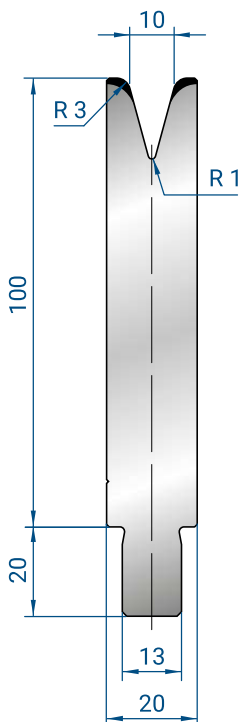

500 mm	8,4 kg
300 mm	5,0 kg
200 mm	3,4 kg
100 mm	1,7 kg
550 mm	9,2 kg
FRAZ. /SECT.	
50 mm	0,8 kg
45 mm	0,8 kg
40 mm	0,7 kg
35 mm	0,6 kg
30 mm	0,5 kg
25 mm	0,4 kg

**3238**

**Mat** = 42CrMo4  
 bonificato /  
 tempered  
**Max T/m** = 30  
 $\alpha = 30^\circ$

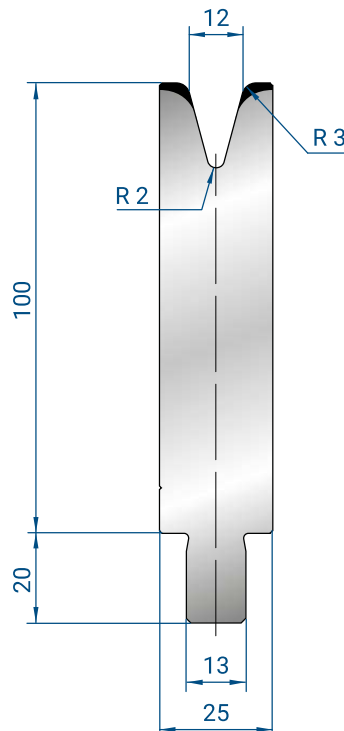

500 mm	10,2 kg
300 mm	6,1 kg
200 mm	4,1 kg
100 mm	2,0 kg
550 mm	11,2 kg
FRAZ. /SECT.	
50 mm	1,0 kg
45 mm	0,9 kg
40 mm	0,8 kg
35 mm	0,7 kg
30 mm	0,6 kg
25 mm	0,5 kg

**3239**

**Mat** = 42CrMo4  
 bonificato /  
 tempered  
**Max T/m** = 40  
 $\alpha = 30^\circ$

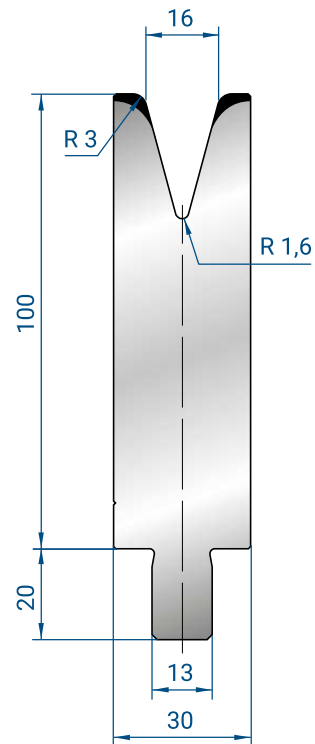

500 mm	11,7 kg
300 mm	7,0 kg
200 mm	4,7 kg
100 mm	2,3 kg
550 mm FRAZ. /SECT.	12,9 kg
50 mm	1,2 kg
45 mm	1,1 kg
40 mm	0,9 kg
35 mm	0,8 kg
30 mm	0,7 kg
25 mm	0,6 kg

## 3240

**Mat** = 42CrMo4

bonificato /

tempered

**Max T/m** = 40

$\alpha$  = 30°

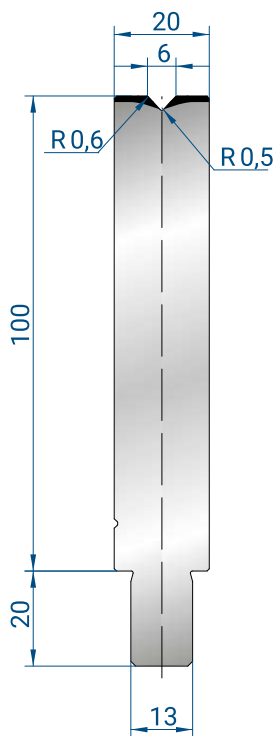

500 mm	8,8 kg
300 mm	5,3 kg
200 mm	3,5 kg
100 mm	1,8 kg
550 mm	9,7 kg
FRAZ. /SECT.	
50 mm	0,9 kg
45 mm	0,8 kg
40 mm	0,7 kg
35 mm	0,6 kg
30 mm	0,5 kg
25 mm	0,4 kg

### 3123

Mat = C45  
 Max T/m = 100  
 $\alpha = 86^\circ$

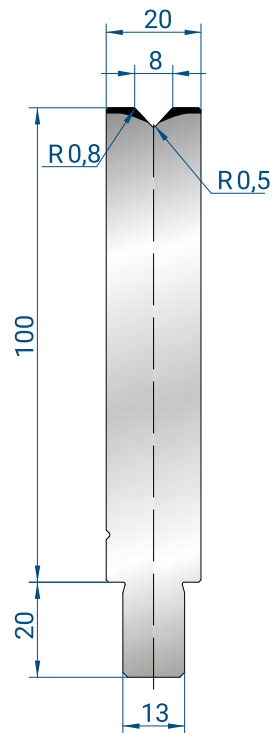

500 mm	8,8 kg
300 mm	5,3 kg
200 mm	3,5 kg
100 mm	1,8 kg
550 mm	9,7 kg
FRAZ. /SECT.	
50 mm	0,9 kg
45 mm	0,8 kg
40 mm	0,7 kg
35 mm	0,6 kg
30 mm	0,5 kg
25 mm	0,4 kg

### 3124

Mat = C45  
 Max T/m = 100  
 $\alpha = 86^\circ$

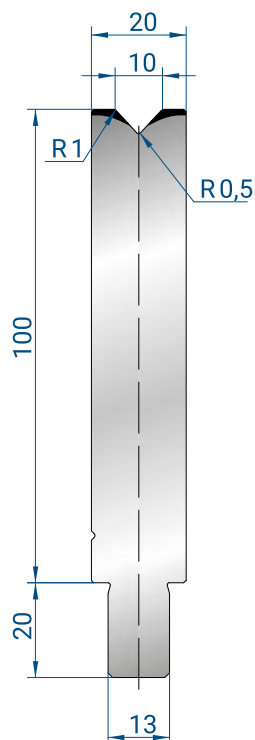

500 mm	8,7 kg
300 mm	5,2 kg
200 mm	3,5 kg
100 mm	1,7 kg
550 mm	9,6 kg
FRAZ. /SECT.	
50 mm	0,9 kg
45 mm	0,8 kg
40 mm	0,7 kg
35 mm	0,6 kg
30 mm	0,5 kg
25 mm	0,4 kg

### 3125

Mat = C45  
 Max T/m = 100  
 $\alpha = 86^\circ$

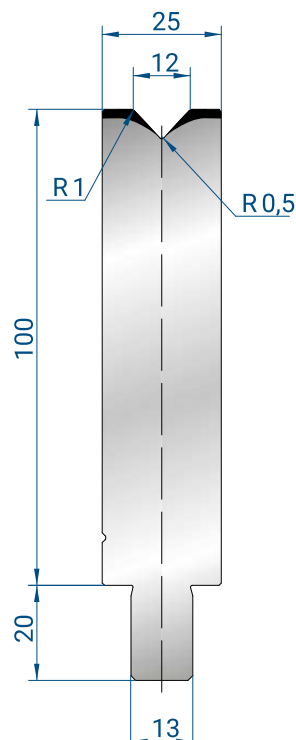

500 mm	10,6 kg
300 mm	6,4 kg
200 mm	4,3 kg
100 mm	2,1 kg
550 mm	11,7 kg
FRAZ. /SECT.	
50 mm	1,1 kg
45 mm	1,0 kg
40 mm	0,9 kg
35 mm	0,7 kg
30 mm	0,6 kg
25 mm	0,5 kg

### 3126

Mat = C45  
 Max T/m = 100  
 $\alpha = 86^\circ$

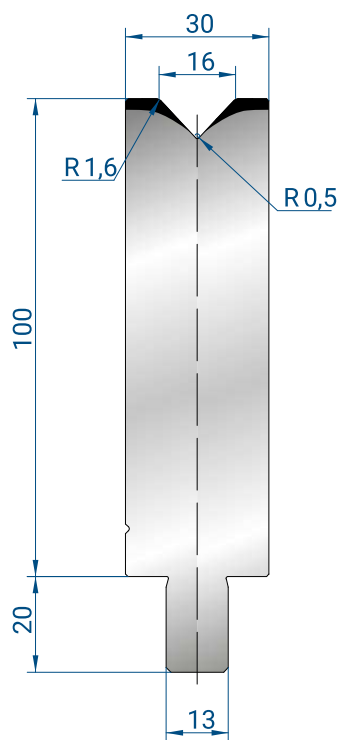

500 mm	12,5 kg
300 mm	7,5 kg
200 mm	5,0 kg
100 mm	2,5 kg
550 mm	13,7 kg
FRAZ. /SECT.	
50 mm	1,2 kg
45 mm	1,1 kg
40 mm	1,0 kg
35 mm	0,9 kg
30 mm	0,7 kg
25 mm	0,6 kg

**3127**

Mat = C45  
Max T/m = 100  
 $\alpha = 86^\circ$

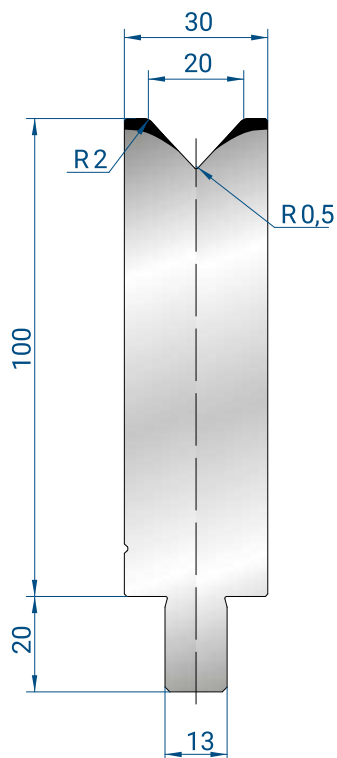

500 mm	12,3 kg
300 mm	7,4 kg
200 mm	4,9 kg
100 mm	2,5 kg
550 mm	13,6 kg
FRAZ. /SECT.	
50 mm	1,2 kg
45 mm	1,1 kg
40 mm	1,0 kg
35 mm	0,9 kg
30 mm	0,7 kg
25 mm	0,6 kg

**3128**

Mat = C45  
Max T/m = 100  
 $\alpha = 86^\circ$

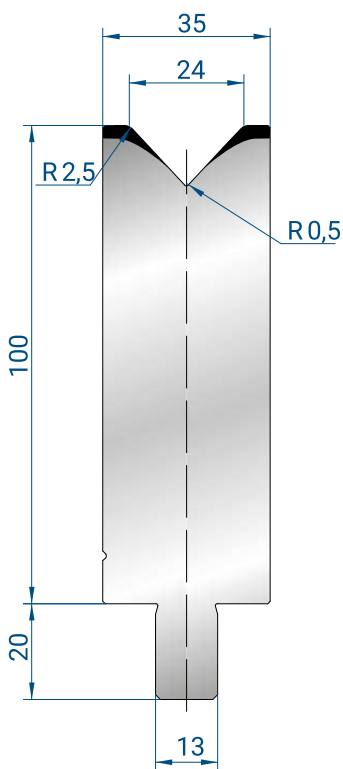

500 mm	14,1 kg
300 mm	8,5 kg
200 mm	5,6 kg
100 mm	2,8 kg
550 mm	15,5 kg
FRAZ. /SECT.	
50 mm	1,4 kg
45 mm	1,3 kg
40 mm	1,1 kg
35 mm	1,0 kg
30 mm	0,8 kg
25 mm	0,7 kg

**3129**

Mat = C45  
Max T/m = 100  
 $\alpha = 86^\circ$

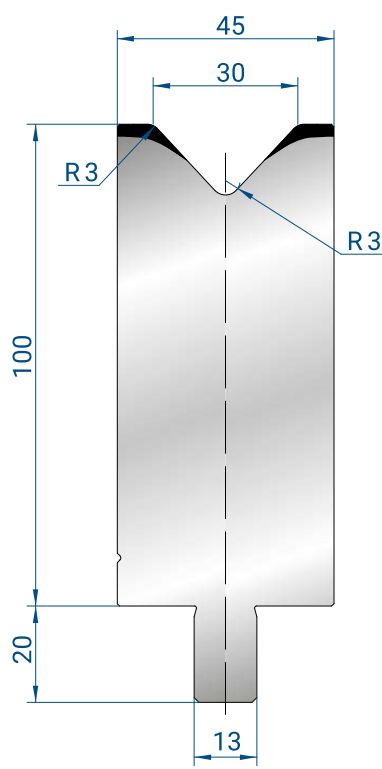

500 mm	17,7 kg
300 mm	10,6 kg
200 mm	7,1 kg
100 mm	3,5 kg
550 mm	19,5 kg
FRAZ. /SECT.	
50 mm	1,8 kg
45 mm	1,6 kg
40 mm	1,4 kg
35 mm	1,2 kg
30 mm	1,1 kg
25 mm	0,9 kg

**3130**

Mat = C45  
Max T/m = 100  
 $\alpha = 86^\circ$

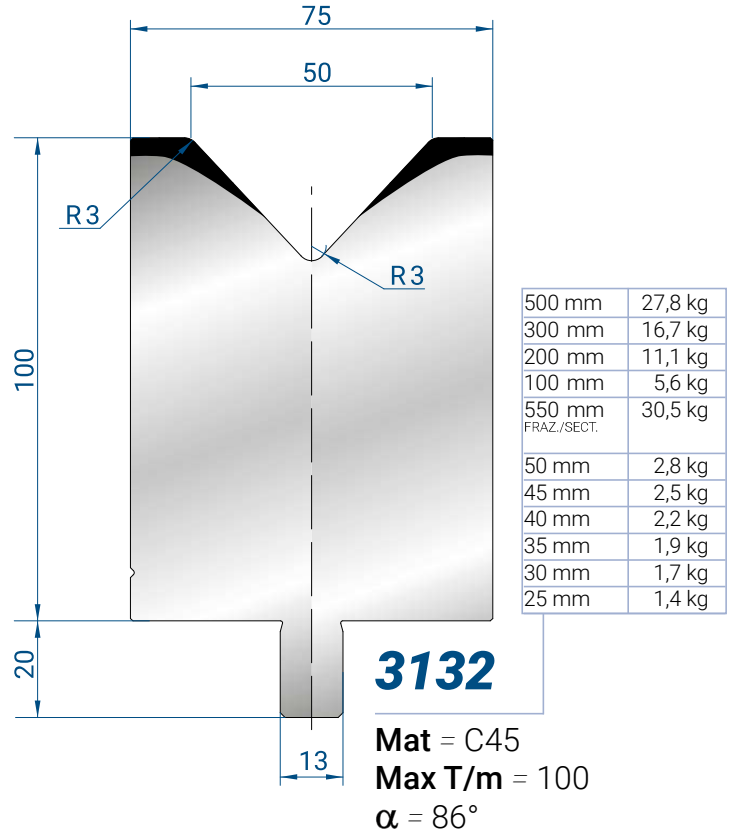
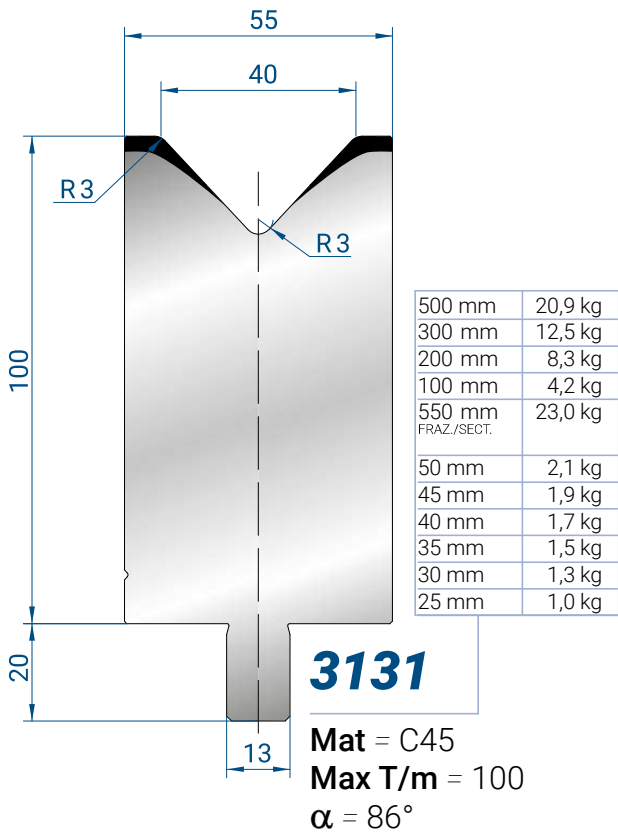

**3133**

Mat = C45  
 Max T/m = 100  
 $\alpha = 80^\circ$

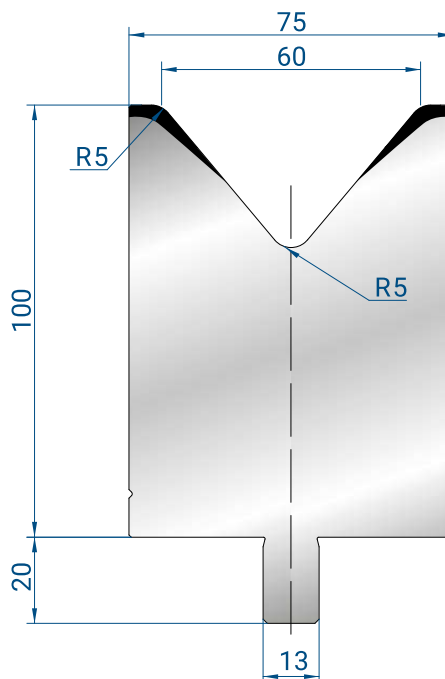

500 mm	26,2 kg
300 mm	15,7 kg
200 mm	10,5 kg
100 mm	5,2 kg
550 mm	28,8 kg
FRAZ./SECT.	
50 mm	2,6 kg
45 mm	2,4 kg
40 mm	2,1 kg
35 mm	1,8 kg
30 mm	1,6 kg
25 mm	1,3 kg

### 3134

Mat = C45  
 Max T/m = 100  
 $\alpha = 80^\circ$

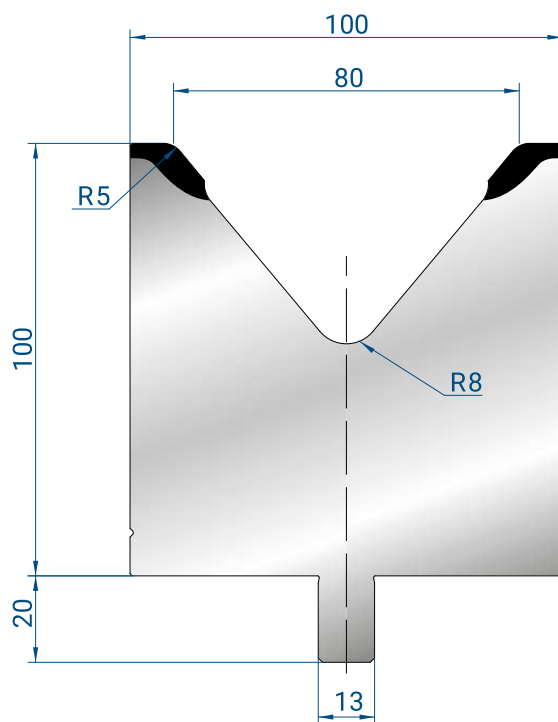

500 mm	32,9 kg
300 mm	19,8 kg
200 mm	13,2 kg
100 mm	6,6 kg
550 mm FRAZ. /SECT.	36,2 kg
50 mm	3,3 kg
45 mm	3,0 kg
40 mm	2,6 kg
35 mm	2,3 kg
30 mm	2,0 kg
25 mm	1,6 kg

### 3135

Mat = C45  
 Max T/m = 100  
 $\alpha = 80^\circ$

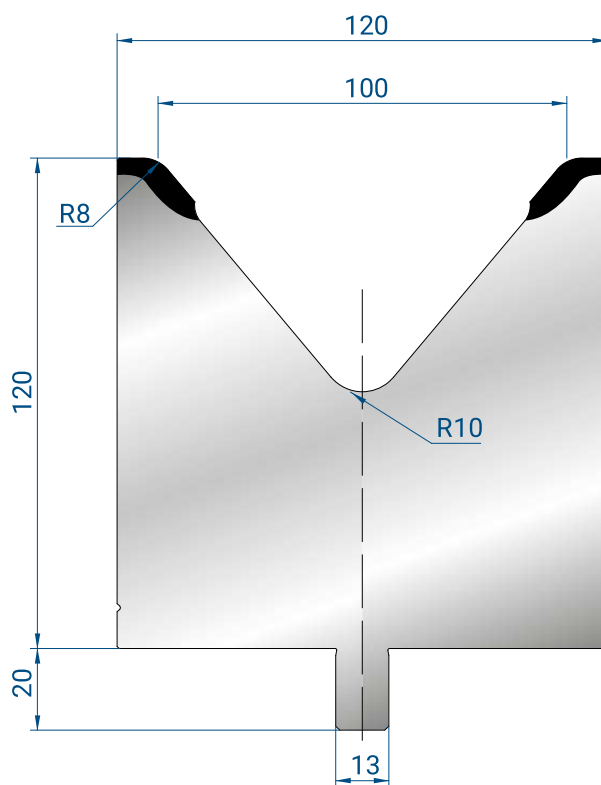

500 mm	44,9 kg
300 mm	26,9 kg
200 mm	17,9 kg
100 mm	9,0 kg
550 mm FRAZ. /SECT.	49,3 kg
50 mm	4,5 kg
45 mm	4,0 kg
40 mm	3,6 kg
35 mm	3,1 kg
30 mm	2,7 kg
25 mm	2,2 kg

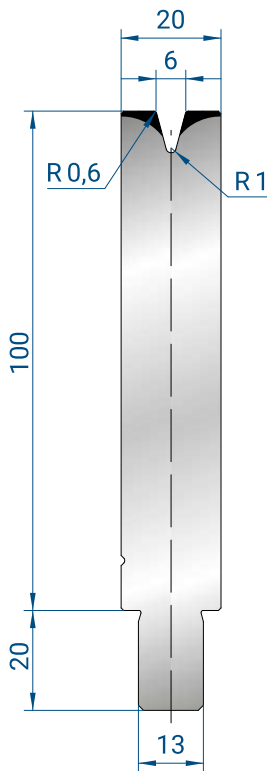

500 mm	8,7 kg
300 mm	5,2 kg
200 mm	3,5 kg
100 mm	1,7 kg
550 mm FRAZ. /SECT.	9,6 kg
50 mm	0,9 kg
45 mm	0,8 kg
40 mm	0,7 kg
35 mm	0,6 kg
30 mm	0,5 kg
25 mm	0,4 kg

### 3136

Mat = C45  
Max T/m = 50  
 $\alpha = 30^\circ$

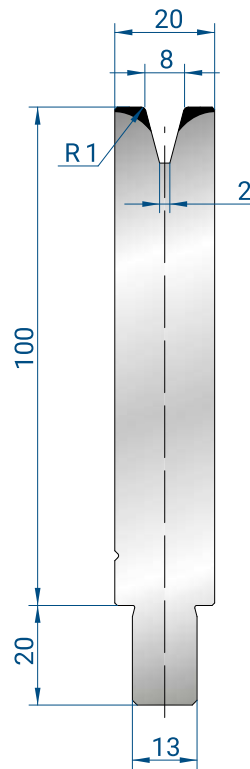

500 mm	8,6 kg
300 mm	5,2 kg
200 mm	3,4 kg
100 mm	1,7 kg
550 mm FRAZ. /SECT.	9,5 kg
50 mm	0,9 kg
45 mm	0,8 kg
40 mm	0,7 kg
35 mm	0,6 kg
30 mm	0,5 kg
25 mm	0,4 kg

### 3137

Mat = C45  
Max T/m = 40  
 $\alpha = 30^\circ$

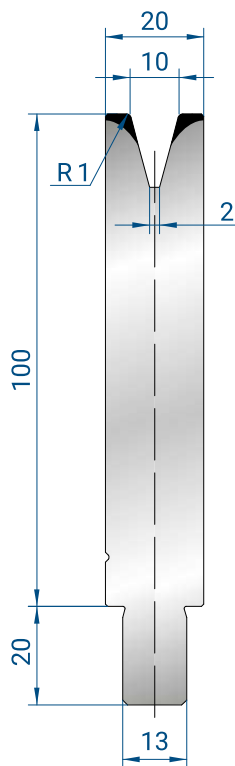

500 mm	8,5 kg
300 mm	5,1 kg
200 mm	3,4 kg
100 mm	1,7 kg
550 mm FRAZ. /SECT.	9,3 kg
50 mm	0,8 kg
45 mm	0,8 kg
40 mm	0,7 kg
35 mm	0,6 kg
30 mm	0,5 kg
25 mm	0,4 kg

### 3138

Mat = C45  
Max T/m = 40  
 $\alpha = 30^\circ$

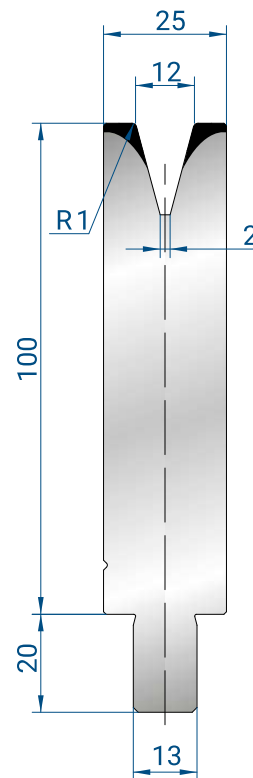

500 mm	10,3 kg
300 mm	6,2 kg
200 mm	4,1 kg
100 mm	2,1 kg
550 mm FRAZ. /SECT.	11,3 kg
50 mm	1,0 kg
45 mm	0,9 kg
40 mm	0,8 kg
35 mm	0,7 kg
30 mm	0,6 kg
25 mm	0,5 kg

### 3139

Mat = C45  
Max T/m = 50  
 $\alpha = 30^\circ$

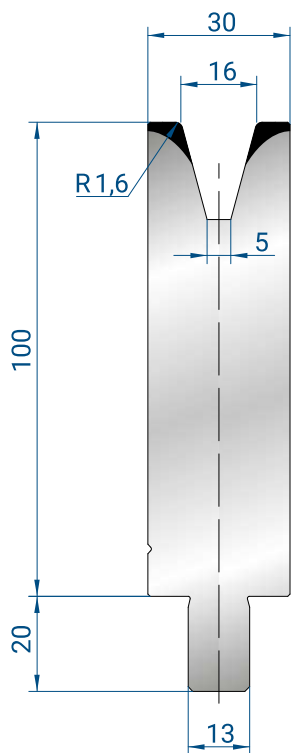

500 mm	11,9 kg
300 mm	7,1 kg
200 mm	4,8 kg
100 mm	2,4 kg
550 mm	13,1 kg
FRAZ. /SECT.	
50 mm	1,2 kg
45 mm	1,1 kg
40 mm	1,0 kg
35 mm	0,8 kg
30 mm	0,7 kg
25 mm	0,6 kg

**3140**

Mat = C45  
 Max T/m = 45  
 $\alpha = 30^\circ$

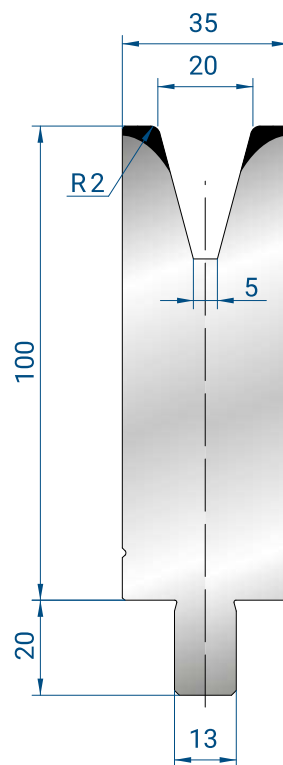

500 mm	13,3 kg
300 mm	8,0 kg
200 mm	5,3 kg
100 mm	2,7 kg
550 mm	14,7 kg
FRAZ. /SECT.	
50 mm	1,3 kg
45 mm	1,2 kg
40 mm	1,1 kg
35 mm	0,9 kg
30 mm	0,8 kg
25 mm	0,7 kg

**3141**

Mat = C45  
 Max T/m = 50  
 $\alpha = 30^\circ$

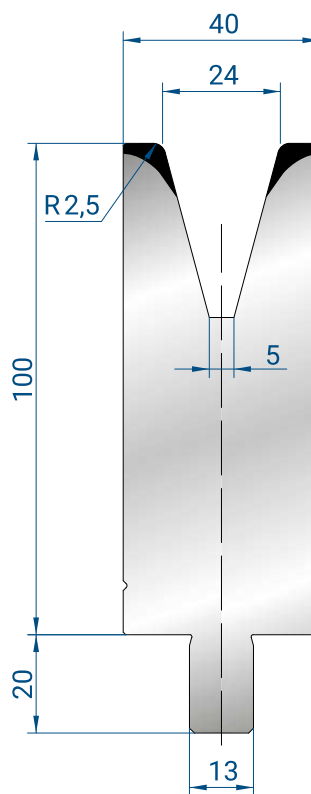

500 mm	14,7 kg
300 mm	8,8 kg
200 mm	5,9 kg
100 mm	2,9 kg
550 mm	16,1 kg
FRAZ. /SECT.	
50 mm	1,5 kg
45 mm	1,3 kg
40 mm	1,2 kg
35 mm	1,0 kg
30 mm	0,9 kg
25 mm	0,7 kg

**3142**

Mat = C45  
 Max T/m = 50  
 $\alpha = 30^\circ$

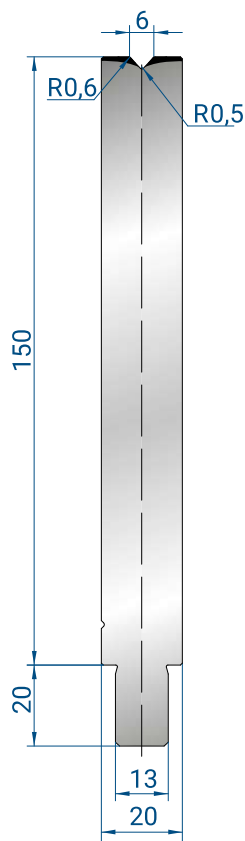

500 mm	12,7 kg
300 mm	7,6 kg
200 mm	5,1 kg
100 mm	2,5 kg
550 mm FRAZ. /SECT.	14,0 kg
50 mm	1,3 kg
45 mm	1,1 kg
40 mm	1,0 kg
35 mm	0,9 kg
30 mm	0,8 kg
25 mm	0,6 kg

**3143**

Mat = C45  
Max T/m = 100  
 $\alpha = 86^\circ$

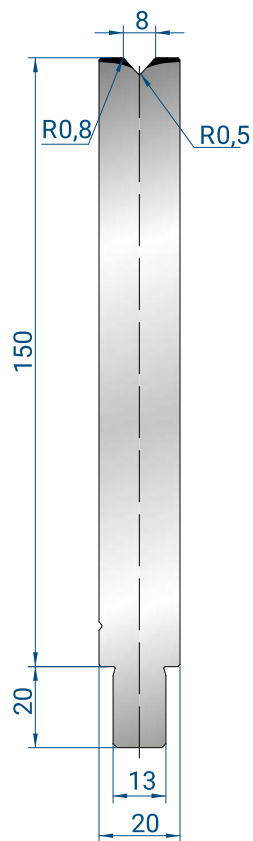

500 mm	12,7 kg
300 mm	7,6 kg
200 mm	5,1 kg
100 mm	2,5 kg
550 mm FRAZ. /SECT.	14,0 kg
50 mm	1,3 kg
45 mm	1,1 kg
40 mm	1,0 kg
35 mm	0,9 kg
30 mm	0,8 kg
25 mm	0,6 kg

**3144**

Mat = C45  
Max T/m = 100  
 $\alpha = 86^\circ$



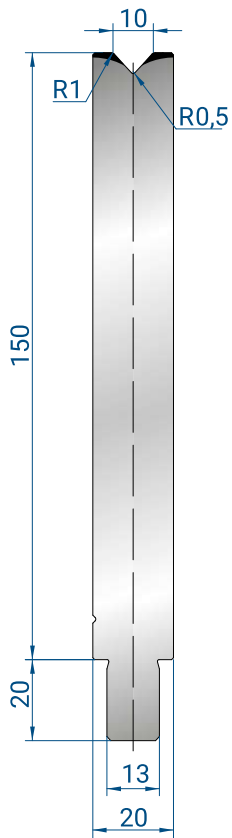

500 mm	12,6 kg
300 mm	7,6 kg
200 mm	5,1 kg
100 mm	2,5 kg
550 mm FRAZ. /SECT.	13,9 kg
50 mm	1,3 kg
45 mm	1,1 kg
40 mm	1,0 kg
35 mm	0,9 kg
30 mm	0,8 kg
25 mm	0,6 kg

### 3145

Mat = C45  
Max T/m = 100  
 $\alpha = 86^\circ$

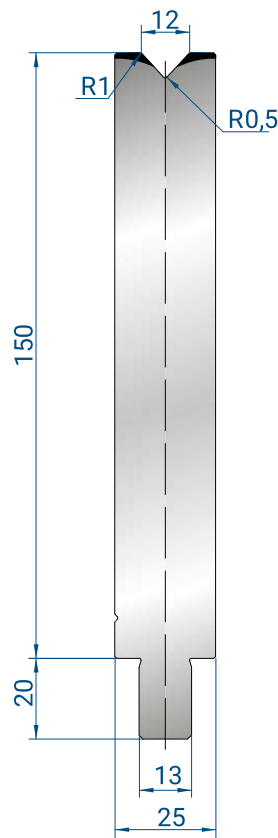

500 mm	15,5 kg
300 mm	9,3 kg
200 mm	6,2 kg
100 mm	3,1 kg
550 mm FRAZ. /SECT.	17,1 kg
50 mm	1,6 kg
45 mm	1,4 kg
40 mm	1,2 kg
35 mm	1,1 kg
30 mm	0,9 kg
25 mm	0,8 kg

### 3146

Mat = C45  
Max T/m = 100  
 $\alpha = 86^\circ$

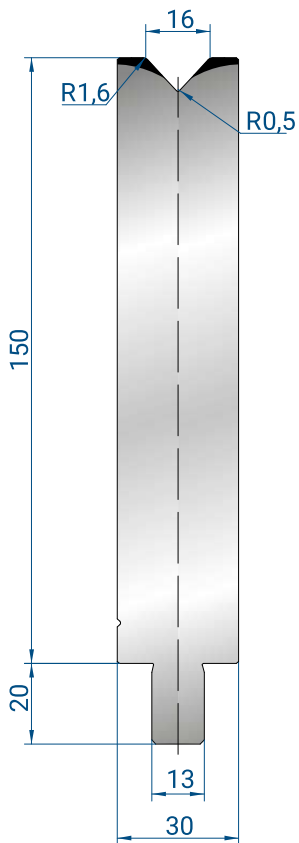

500 mm	18,4 kg
300 mm	11,0 kg
200 mm	7,3 kg
100 mm	3,7 kg
550 mm FRAZ. /SECT.	20,2 kg
50 mm	1,8 kg
45 mm	1,7 kg
40 mm	1,5 kg
35 mm	1,3 kg
30 mm	1,1 kg
25 mm	0,9 kg

### 3147

Mat = C45  
Max T/m = 100  
 $\alpha = 86^\circ$

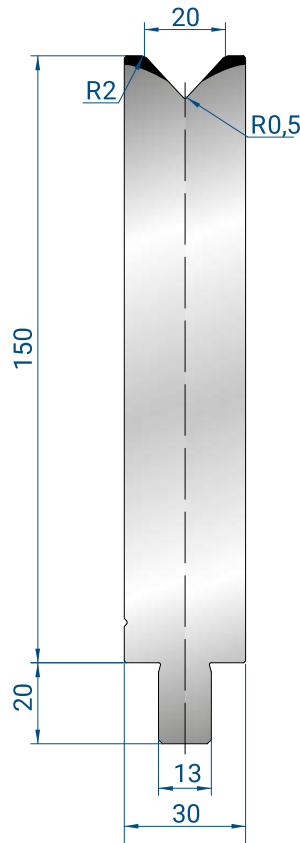

500 mm	18,2 kg
300 mm	10,9 kg
200 mm	7,3 kg
100 mm	3,6 kg
550 mm FRAZ. /SECT.	20,0 kg
50 mm	1,8 kg
45 mm	1,6 kg
40 mm	1,5 kg
35 mm	1,3 kg
30 mm	1,1 kg
25 mm	0,9 kg

### 3148

Mat = C45  
Max T/m = 100  
 $\alpha = 86^\circ$

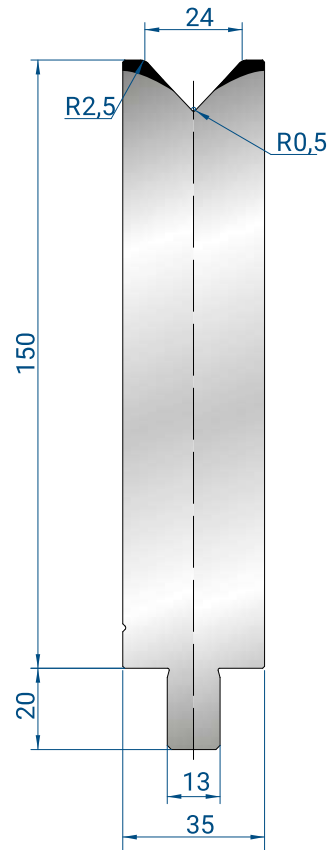

500 mm	21,0 kg
300 mm	12,6 kg
200 mm	8,4 kg
100 mm	4,2 kg
550 mm FRAZ. /SECT.	23,1 kg
50 mm	2,1 kg
45 mm	1,9 kg
40 mm	1,7 kg
35 mm	1,5 kg
30 mm	1,3 kg
25 mm	1,0 kg

**3149**

**Mat = C45**

**Max T/m = 100**

**$\alpha = 86^\circ$**

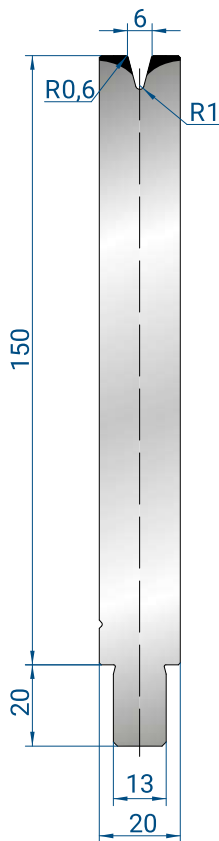

500 mm	12,6 kg
300 mm	7,6 kg
200 mm	5,1 kg
100 mm	2,5 kg
550 mm FRAZ. /SECT.	13,9 kg
50 mm	1,3 kg
45 mm	1,1 kg
40 mm	1,0 kg
35 mm	0,9 kg
30 mm	0,8 kg
25 mm	0,6 kg

**3150**

**Mat = C45**

**Max T/m = 50**

**$\alpha = 30^\circ$**

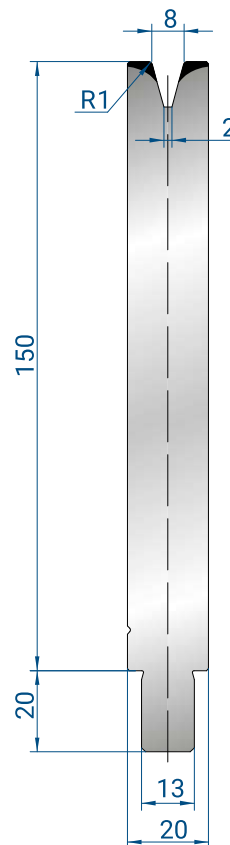

500 mm	12,5 kg
300 mm	7,5 kg
200 mm	5,0 kg
100 mm	2,5 kg
550 mm FRAZ. /SECT.	13,8 kg
50 mm	1,3 kg
45 mm	1,2 kg
40 mm	1,0 kg
35 mm	0,9 kg
30 mm	0,8 kg
25 mm	0,7 kg

**3151**

**Mat = C45**

**Max T/m = 40**

**$\alpha = 30^\circ$**

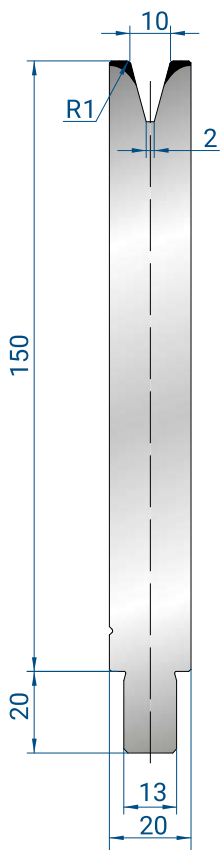

500 mm	12,4 kg
300 mm	7,4 kg
200 mm	5,0 kg
100 mm	2,5 kg
550 mm FRAZ. /SECT.	13,6 kg
50 mm	1,2 kg
45 mm	1,1 kg
40 mm	1,0 kg
35 mm	0,9 kg
30 mm	0,7 kg
25 mm	0,6 kg

### 3152

Mat = C45  
Max T/m = 40  
 $\alpha = 30^\circ$

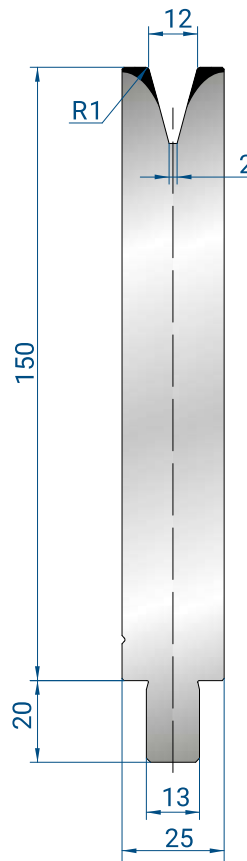

500 mm	15,2 kg
300 mm	9,1 kg
200 mm	6,1 kg
100 mm	3,0 kg
550 mm FRAZ. /SECT.	16,7 kg
50 mm	1,5 kg
45 mm	1,4 kg
40 mm	1,2 kg
35 mm	1,1 kg
30 mm	0,9 kg
25 mm	0,8 kg

### 3153

Mat = C45  
Max T/m = 50  
 $\alpha = 30^\circ$

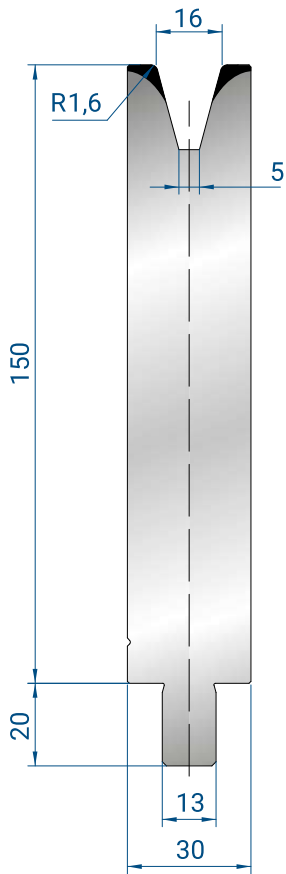

500 mm	17,8 kg
300 mm	10,7 kg
200 mm	7,1 kg
100 mm	3,6 kg
550 mm FRAZ. /SECT.	19,6 kg
50 mm	1,8 kg
45 mm	1,6 kg
40 mm	1,4 kg
35 mm	1,2 kg
30 mm	1,1 kg
25 mm	0,9 kg

### 3154

Mat = C45  
Max T/m = 45  
 $\alpha = 30^\circ$

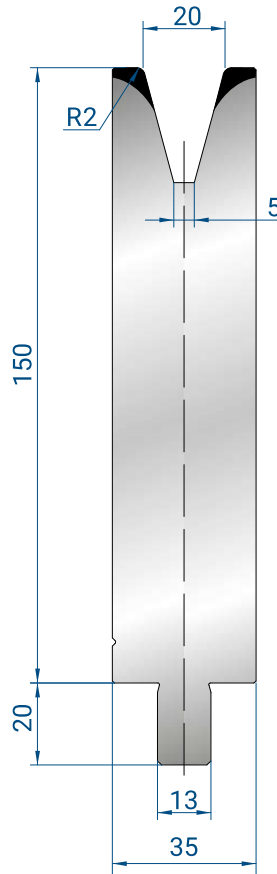

500 mm	20,2 kg
300 mm	12,1 kg
200 mm	8,1 kg
100 mm	4,0 kg
550 mm FRAZ. /SECT.	22,2 kg
50 mm	2,0 kg
45 mm	1,8 kg
40 mm	1,6 kg
35 mm	1,4 kg
30 mm	1,2 kg
25 mm	1,0 kg

### 3155

Mat = C45  
Max T/m = 50  
 $\alpha = 30^\circ$

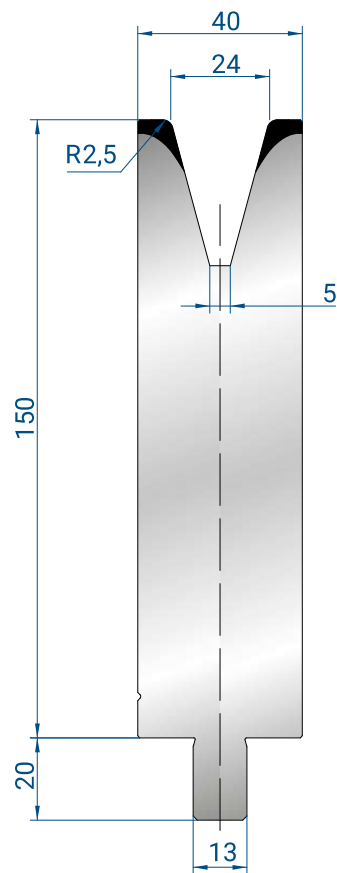

500 mm	22,5 kg
300 mm	13,5 kg
200 mm	9,0 kg
100 mm	4,5 kg
550 mm FRAZ. /SECT.	24,7 kg
50 mm	2,2 kg
45 mm	2,0 kg
40 mm	1,8 kg
35 mm	1,6 kg
30 mm	1,3 kg
25 mm	1,1 kg

**3156**

**Mat = C45**

**Max T/m = 50**

**$\alpha = 30^\circ$**



# ACCESSORIO PIEGASCHIACCIA FLATTENING HEMMING TOOLS ACCESSORY



**FORATURA MATRICI NON COMPRESA,  
PER UN PREVENTIVO FARE RIFERIMEN-  
TO AL CODICE 8108.  
PERFORATION OF DIES NOT INCLUDED,  
FOR A SUMMARY PLEASE REFER  
TO CODE 8108.**

500 mm	13,0 kg
300 mm	7,8 kg
200 mm	5,2 kg
100 mm	2,6 kg
550 mm FRAZ. /SECT.	13,0 kg
50 mm	1,0 kg
45 mm	1,0 kg
40 mm	1,0 kg
35 mm	1,0 kg
30 mm	1,0 kg
25 mm	1,0 kg

## 4330

**Mat = C45**

**Max T/m = 40**

**$\alpha = 30^\circ$**

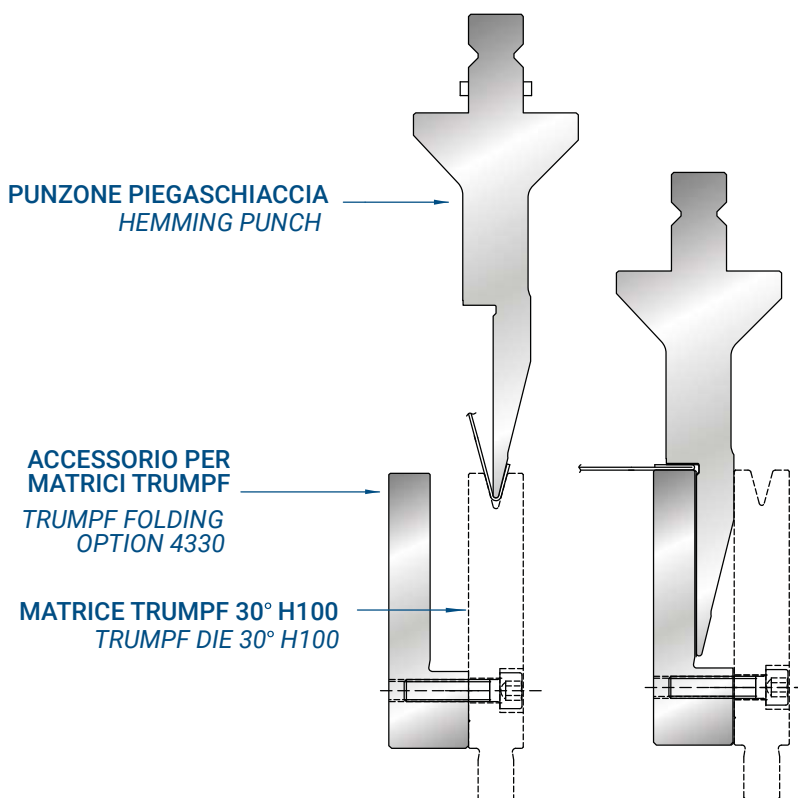
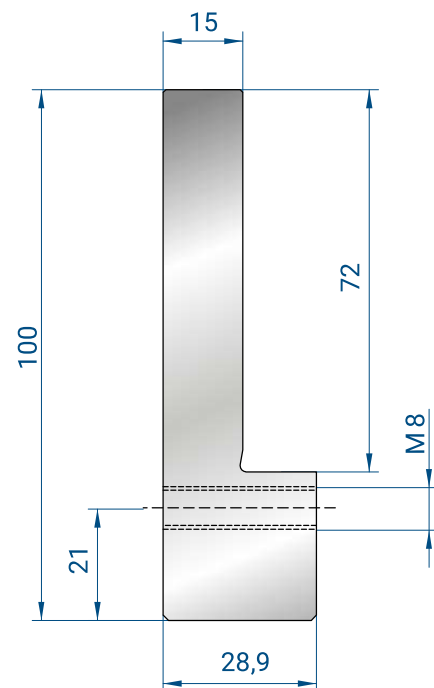

TRUMPF STYLE

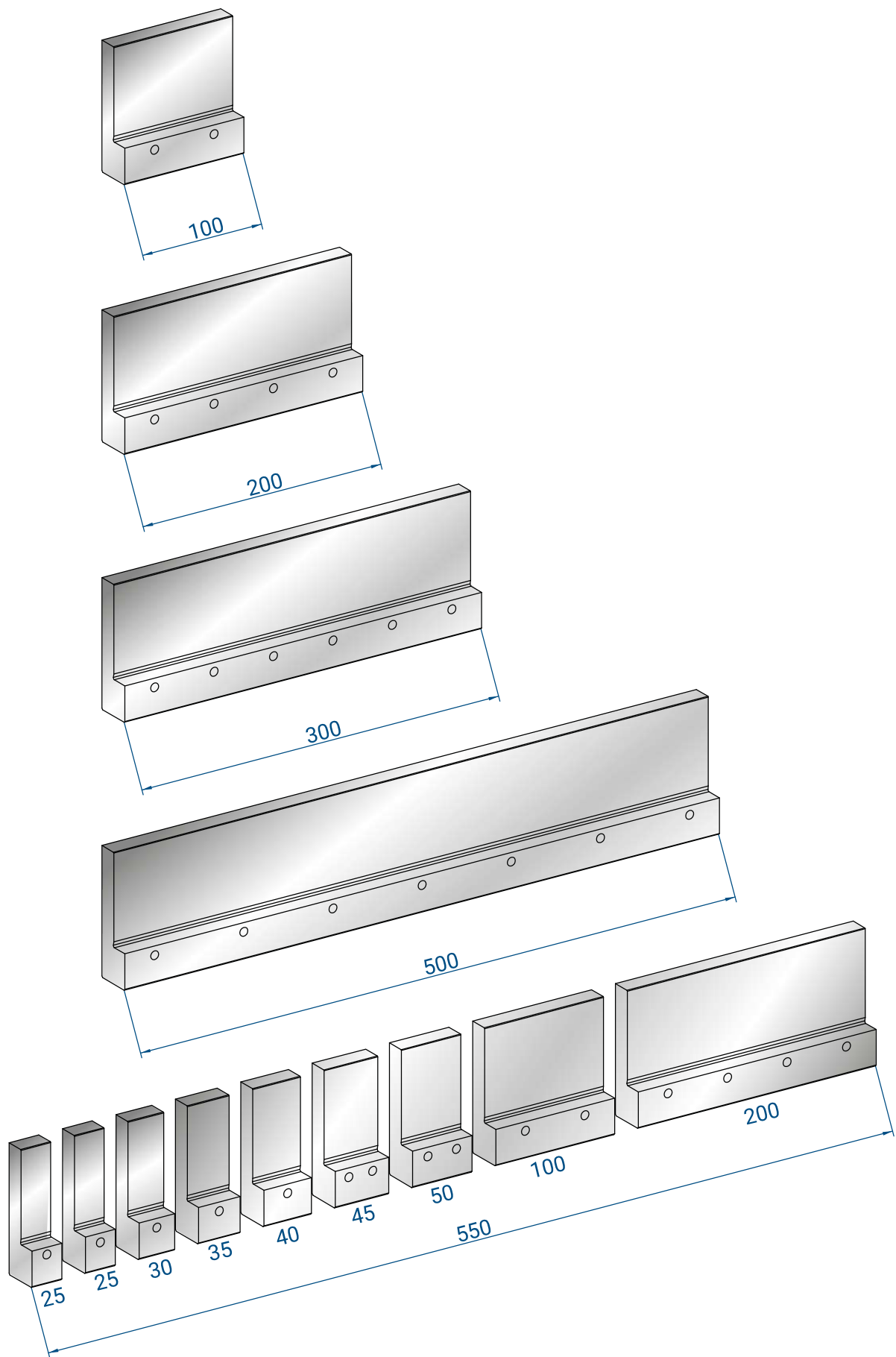

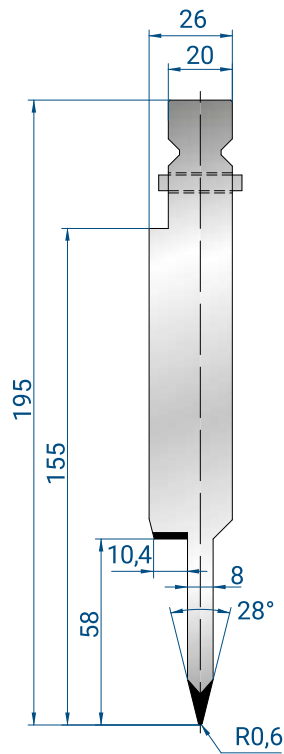

## 1249

**Mat** = C45  
bonificato / *tempered*  
**Max T/m** = 80

500 mm	14,3 kg
550 mm FRAZ. /SECT.	14,0 kg

### Spessore / *Thickness*

Max 1,2 mm  
Ferro / *Mild steel*

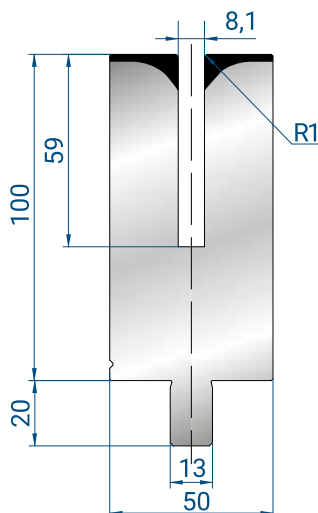

## 3157

**Mat** = C45  
bonificato / *tempered*  
**Max T/m** = 50

500 mm	18,7 kg
550 mm FRAZ. /SECT.	20,6 kg
100 mm	3,7 kg

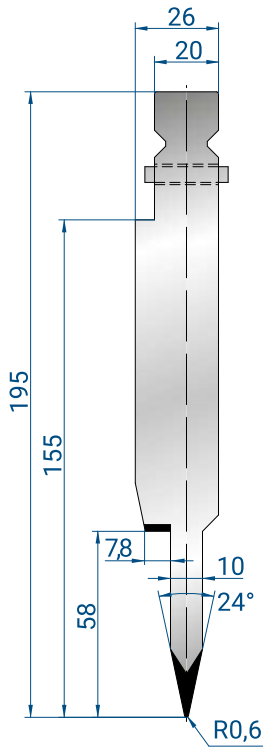
**1250**

**Mat** = C45  
 bonificato / *tempered*  
**Max T/m** = 50

500 mm	14,6 kg
550 mm FRAZ. /SECT.	14,3 kg

**Spessore / Thickness**

Max 1,5 mm  
 Ferro / *Mild steel*

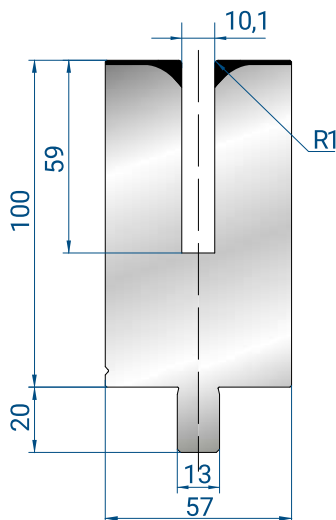
**3174**

**Mat** = C45  
 bonificato / *tempered*  
**Max T/m** = 50

500 mm	21,0 kg
550 mm FRAZ. /SECT.	23,1 kg
100 mm	4,2 kg

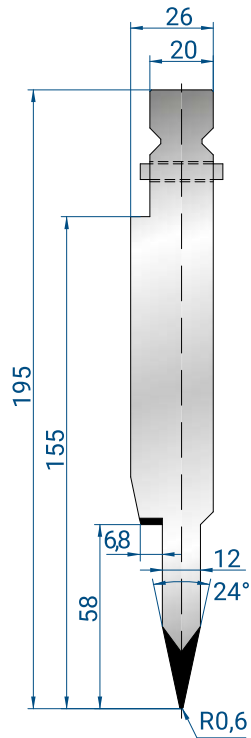
**1251**

**Mat** = C45  
 bonificato / *tempered*  
**Max T/m** = 50

500 mm	14,9 kg
550 mm FRAZ. /SECT.	14,6 kg

**Spessore / Thickness**

Max 1,5 mm  
 Ferro / *Mild steel*

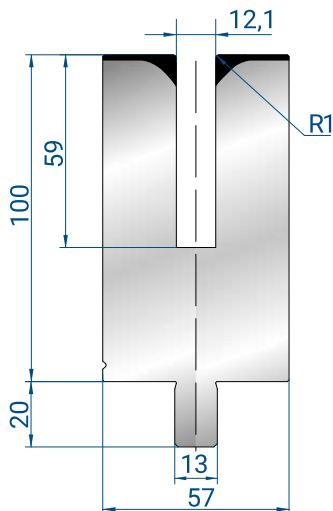
**3175**

**Mat** = C45  
 bonificato / *tempered*  
**Max T/m** = 50

500 mm	20,5 kg
550 mm FRAZ. /SECT.	22,6 kg
100 mm	4,1 kg



# WILA STYLE

**Gli utensili superiori e inferiori elencati in questa sezione possono essere installati sulle piegatrici:**

Trumpf, LVD , Darley, RPC Piegatrici,  
Safan e su altre piegatrici  
equipaggiate con Sistema NSCL.

Questi utensili possono essere installati anche su  
altre piegatrici tramite adattatori superiori e inferiori.

***The upper and lower tooling listed in this section  
could be installed on the following press brakes:***

*Trumpf, Darley, RPC Piegatrici,  
Safan, and other press brakes  
equipped with Wila style clamping system.*

*They could even be installed on press brakes  
equipped with different clamping system by choosing  
the appropriate upper and lower adapters.*



VEDI PAG. 158 PER SCHEMA FRAZIONATURA MATRICI  
 SEE PAGE 158 FOR DIE SEGMENTATION DIAGRAM

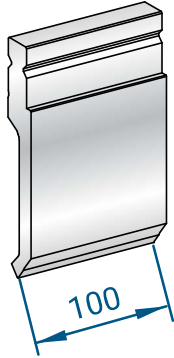
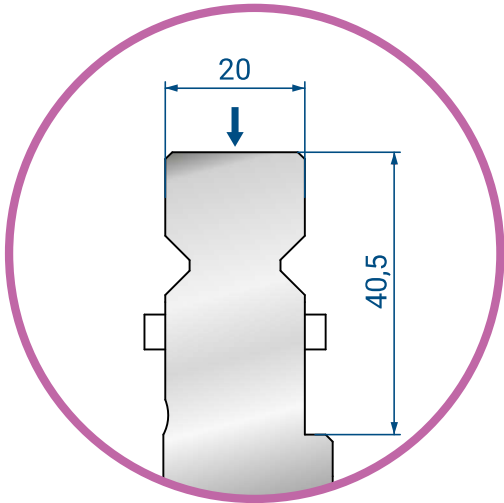

IL PULSANTE DI SICUREZZA VIENE MONTATO STANDARD SU TUTTI GLI UTENSILI CON PESO FINO A 12,5 KG

THE SAFETY BUTTON IS A STANDARD SUPPLY ON ALL TOOLING UP TO 12.5 KG WEIGH

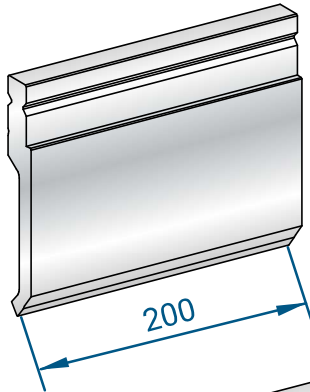

LUNGHEZZE STANDARD  
 STANDARD LENGTHS

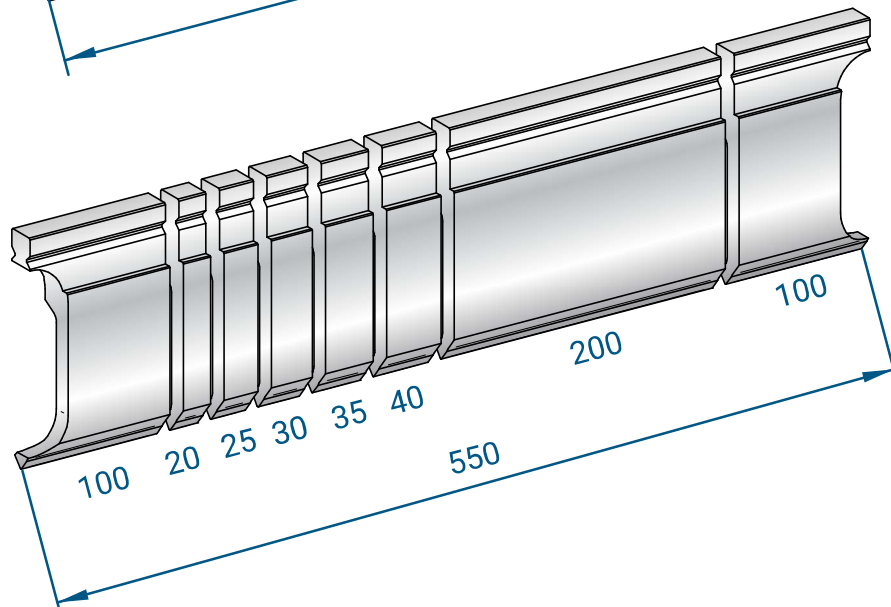
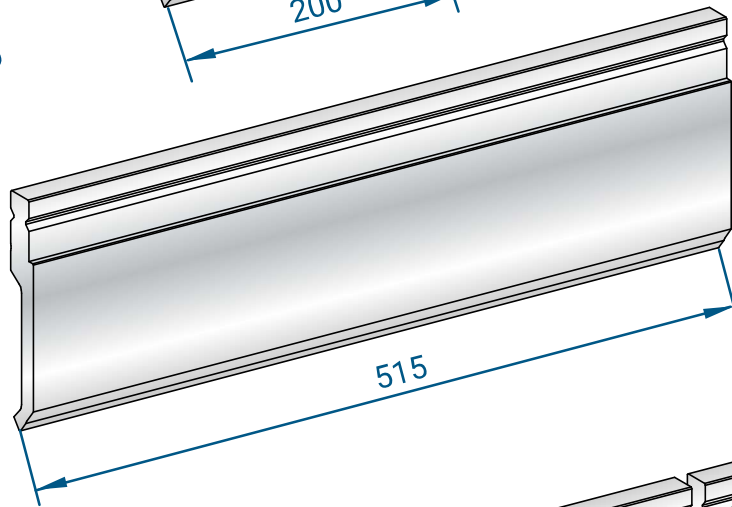

**FRESATURA SCARPETTA**  
*MILLED HORN*

---

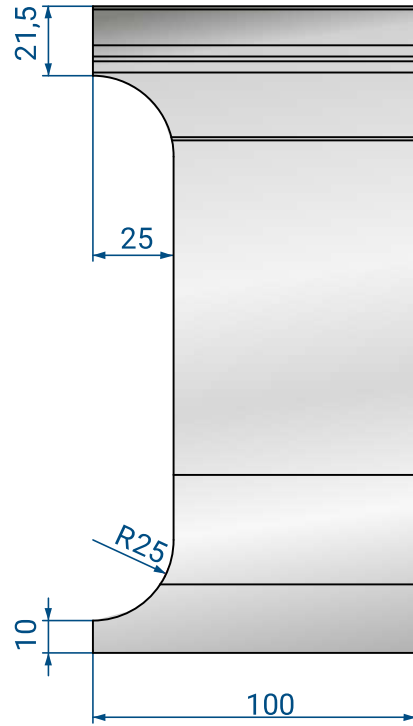

**MODIFICHE A RICHIESTA / MODIFICATIONS ON REQUEST**

**SCARPETTE SPECIALI**  
*SPECIAL HORNS*

---

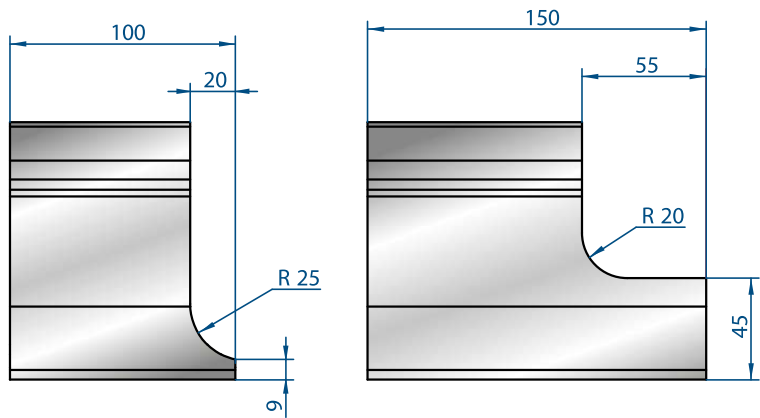

**TAGLI A RICHIESTA**  
*SPECIAL SEGMENTATION*

---



**MODIFICA RAGGIO**  
*RADIUS MODIFICATION*

---

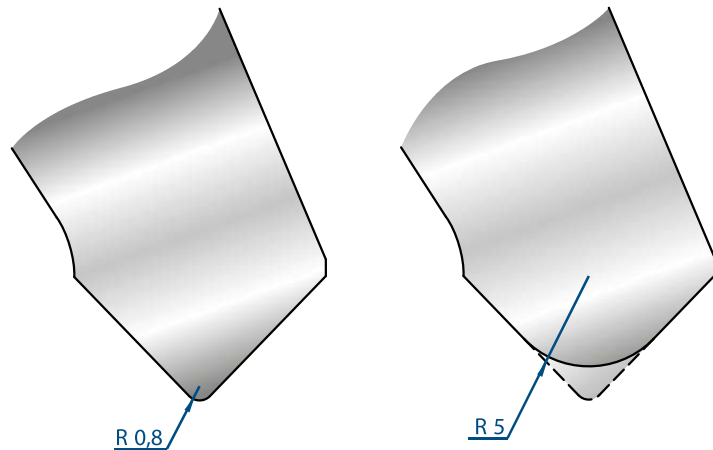

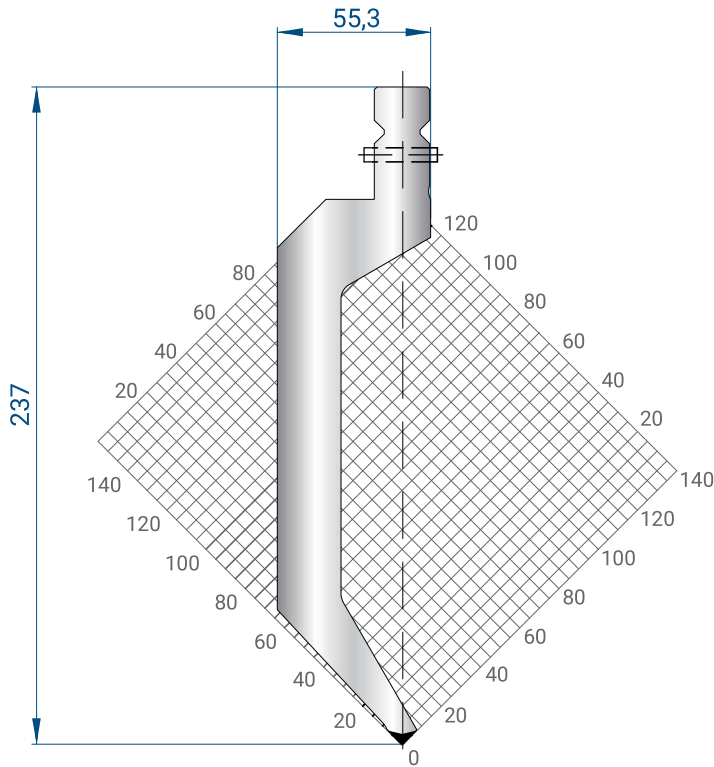

### 1324

**Mat** = 42 CrMo4  
 bonificato / tempered  
**H** = 237.00  
**Max T/m** = 65  
 $\alpha = 86^\circ$   
**R** = 1

515 mm	22,5 kg
200 mm	8,7 kg
100 mm	4,4 kg
550 mm FRAZ. / SECT.	22,3 kg

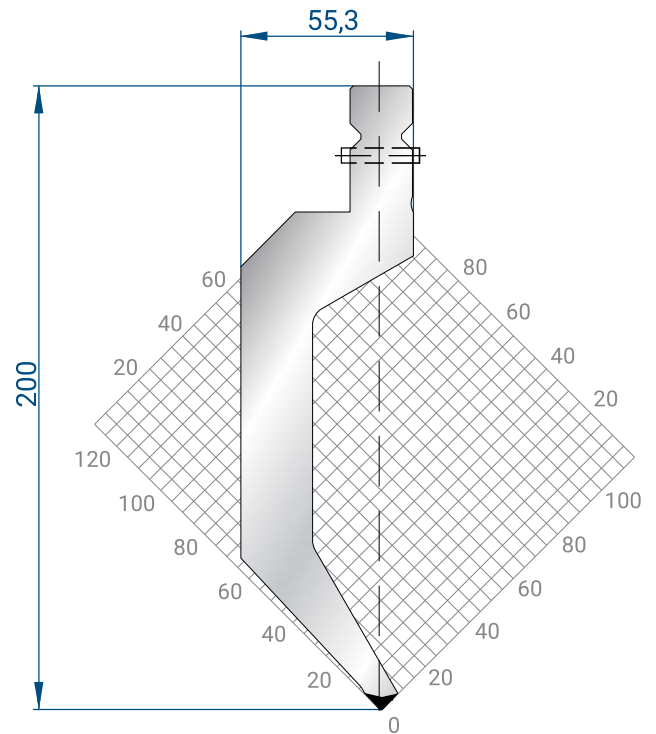

### 1323

**Mat** = 42 CrMo4  
 bonificato / tempered  
**H** = 200.00  
**Max T/m** = 65  
 $\alpha = 86^\circ$   
**R** = 1

515 mm	19,1 kg
200 mm	7,4 kg
100 mm	3,7 kg
550 mm FRAZ. / SECT.	19,0 kg

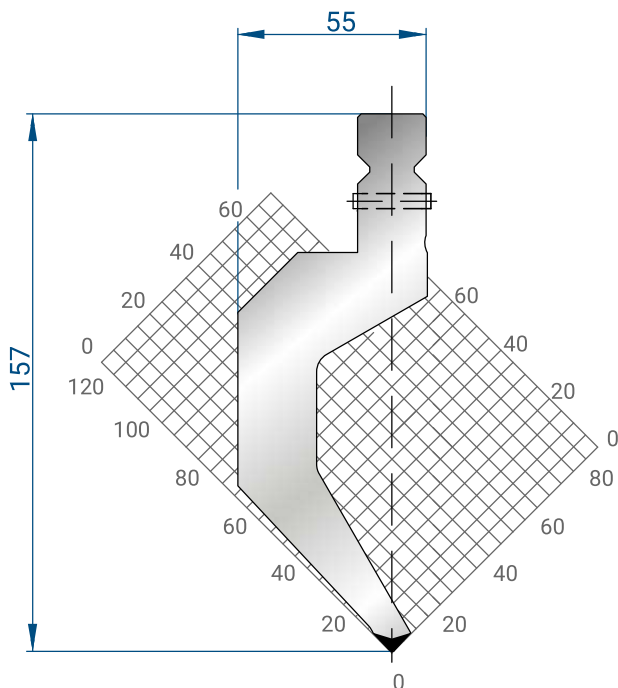

### 1328

**Mat** = 42 CrMo4  
 bonificato / tempered  
**H** = 157.00  
**Max T/m** = 70  
 $\alpha = 86^\circ$   
**R** = 1

515 mm	15,0 kg
200 mm	5,8 kg
100 mm	2,9 kg
550 mm FRAZ. / SECT.	14,9 kg

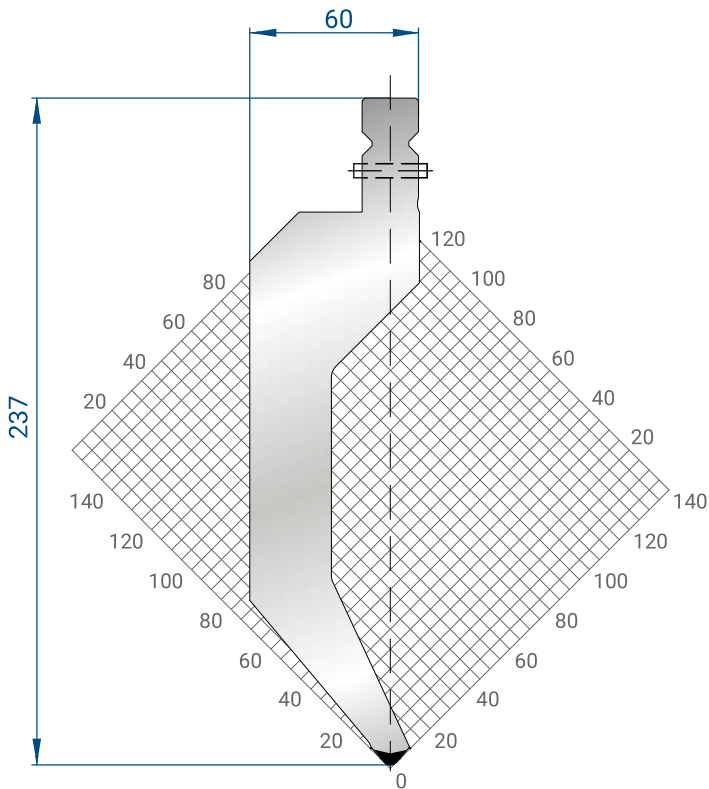

### 1333

**Mat** = 42 CrMo4  
 bonificato / *tempered*  
**H** = 237.00  
**Max T/m** = 100  
 $\alpha$  = 80°  
**R** = 3

515 mm	28,9 kg
200 mm	11,2 kg
100 mm	5,6 kg
550 mm FRAZ. / SECT.	28,4 kg

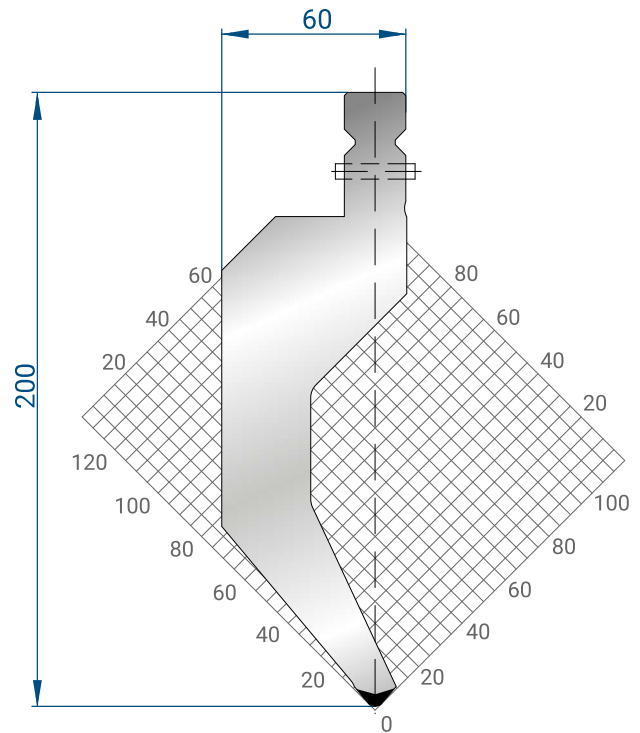

### 1332

**Mat** = 42 CrMo4  
 bonificato / *tempered*  
**H** = 200.00  
**Max T/m** = 100  
 $\alpha$  = 80°  
**R** = 3

515 mm	24,6 kg
200 mm	9,6 kg
100 mm	4,8 kg
550 mm FRAZ. / SECT.	24,1 kg



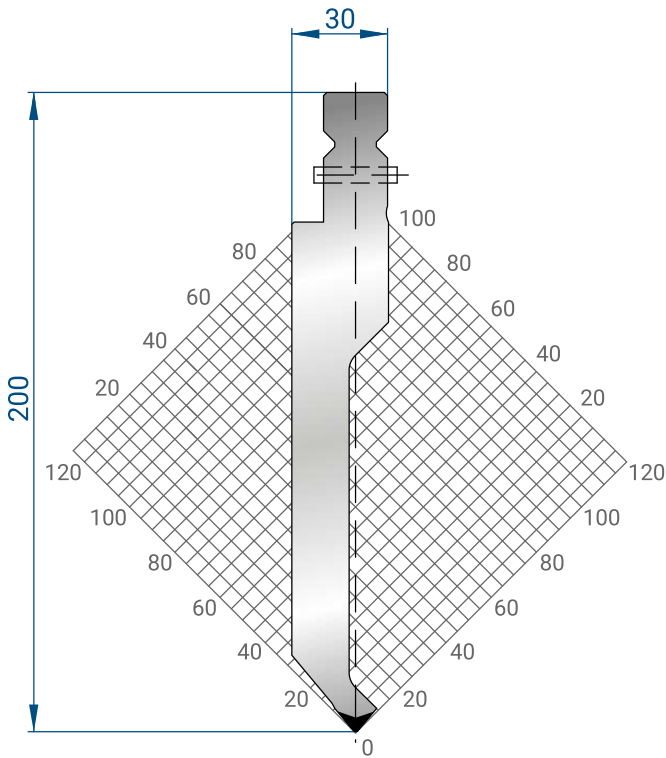

### 1330

**Mat** = 42 CrMo4  
 bonificato / *tempered*  
**H** = 200.00  
**Max T/m** = 80  
 $\alpha$  = 80°  
**R** = 1

515 mm	16,0 kg
200 mm	6,2 kg
100 mm	3,1 kg
550 mm FRAZ. / SECT.	15,8 kg

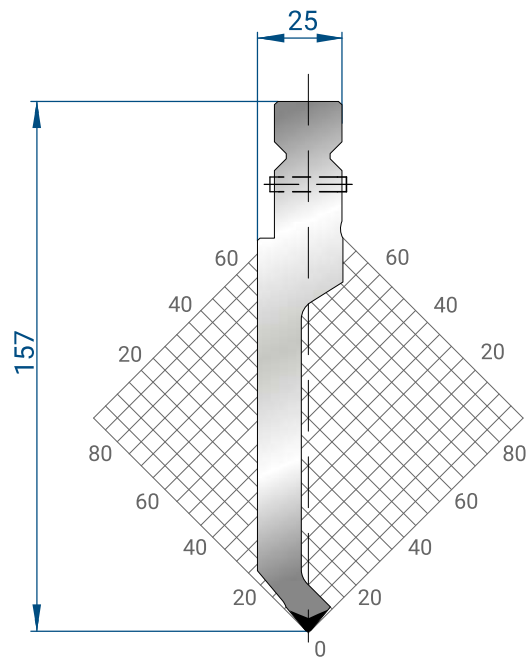

### 1329

**Mat** = 42 CrMo4  
 bonificato / *tempered*  
**H** = 157.00  
**Max T/m** = 100  
 $\alpha$  = 80°  
**R** = 1

515 mm	9,9 kg
200 mm	3,8 kg
100 mm	1,9 kg
550 mm FRAZ. / SECT.	9,8 kg



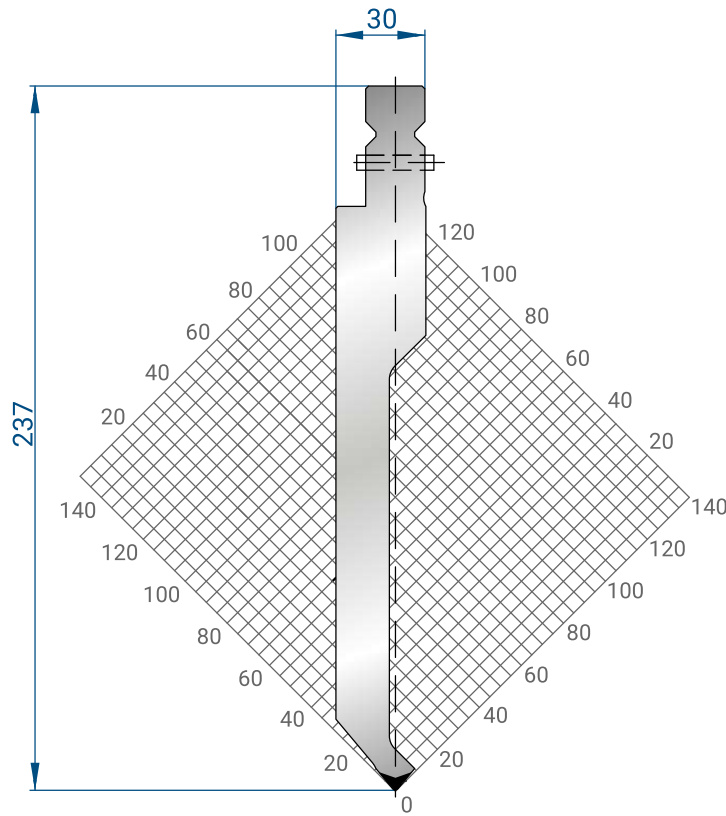

## 1331

**Mat** = 42 CrMo4  
 bonificato / *tempered*  
**H** = 237.00  
**Max T/m** = 80  
 $\alpha$  = 80°  
**R** = 1

515 mm	19,3 kg
200 mm	7,5 kg
100 mm	3,7 kg
550 mm FRAZ. / SECT.	17,6 kg



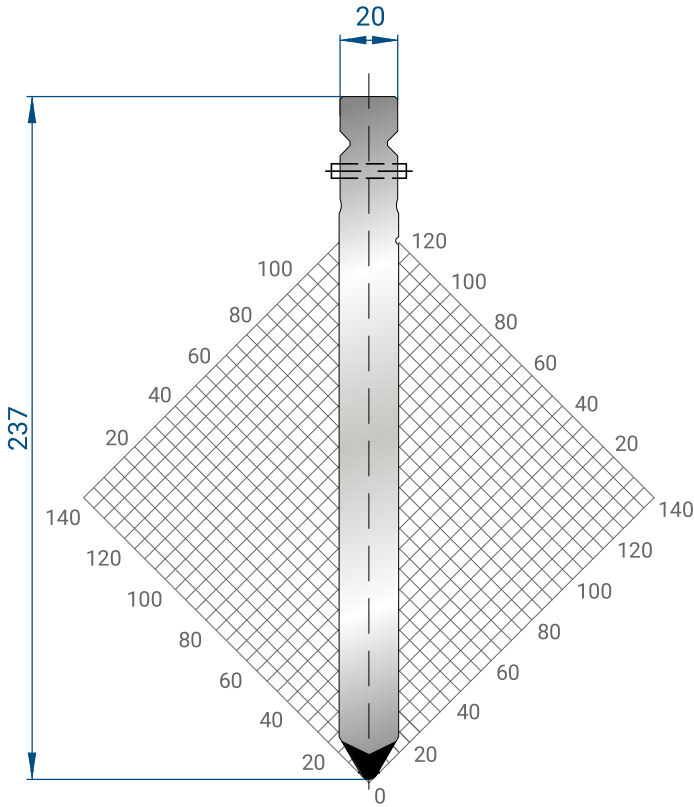

### 1336

**Mat** = 42 CrMo4  
 bonificato / tempered  
**H** = 237.00  
**Max T/m** = 160  
 $\alpha = 60^\circ$   
**R** = 3

515 mm	19,0 kg
200 mm	7,4 kg
100 mm	3,7 kg
550 mm FRAZ. / SECT.	18,7 kg

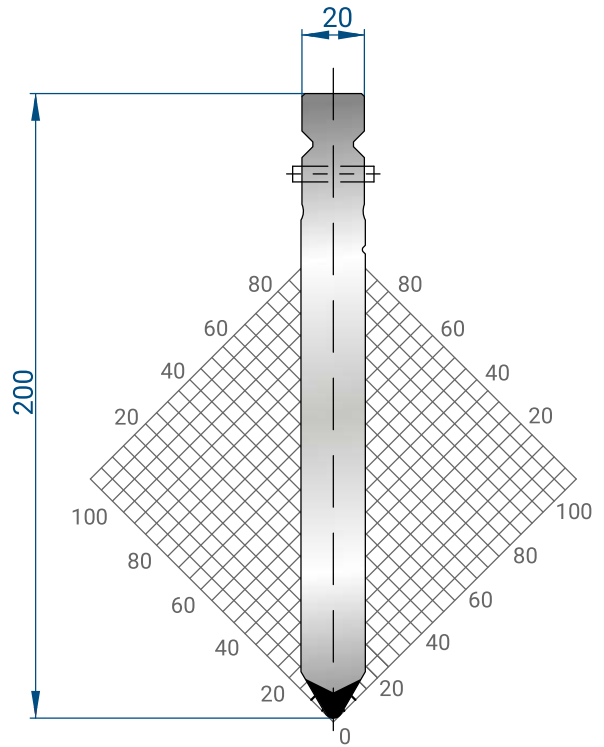

### 1335

**Mat** = 42 CrMo4  
 bonificato / tempered  
**H** = 200.00  
**Max T/m** = 160  
 $\alpha = 60^\circ$   
**R** = 3

515 mm	15,9 kg
200 mm	6,2 kg
100 mm	3,1 kg
550 mm FRAZ. / SECT.	15,7 kg

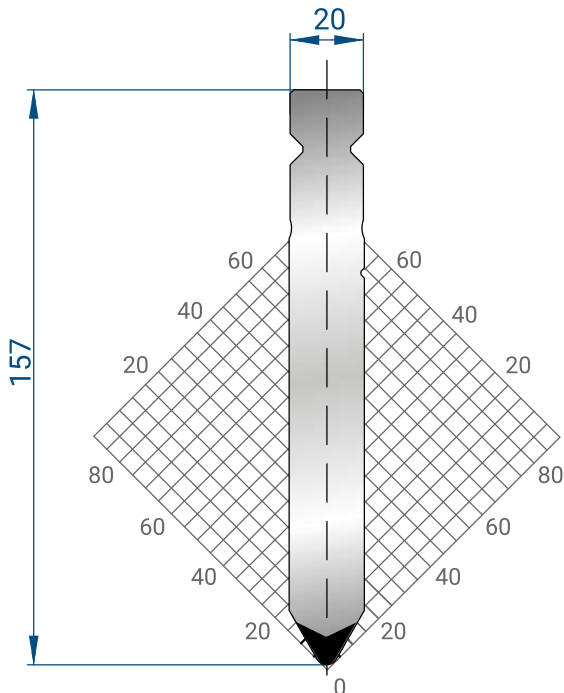

### 1334

**Mat** = 42 CrMo4  
 bonificato / tempered  
**H** = 157.00  
**Max T/m** = 160  
 $\alpha = 60^\circ$   
**R** = 3

515 mm	12,3 kg
200 mm	4,8 kg
100 mm	2,4 kg
550 mm FRAZ. / SECT.	12,2 kg

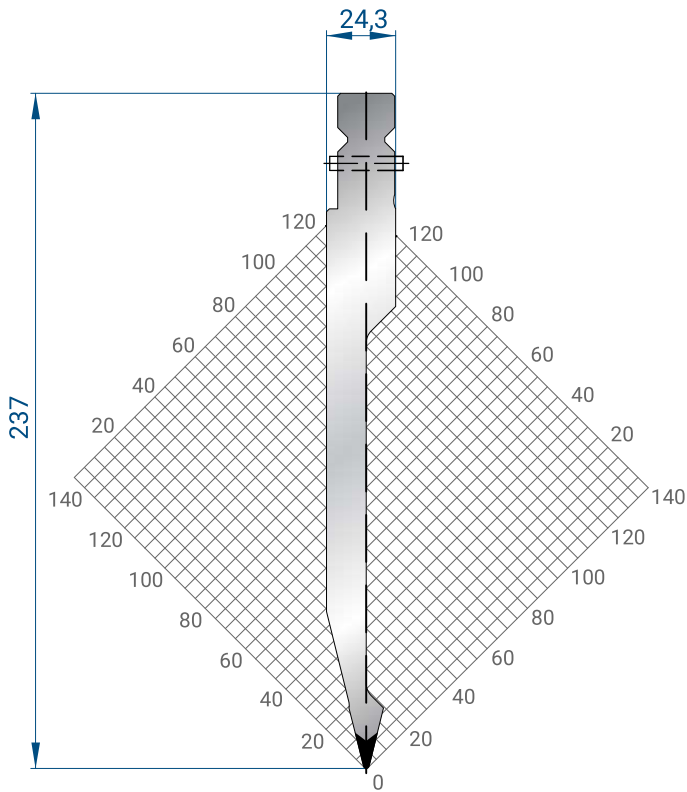

### 1327

**Mat** = 42 CrMo4  
 bonificato / tempered  
**H** = 237.00  
**Max T/m** = 80  
 $\alpha$  = 28°  
**R** = 1

515 mm	14,7 kg
200 mm	5,7 kg
100 mm	2,85 kg
550 mm	14,7 kg
FRAZ. / SECT.	

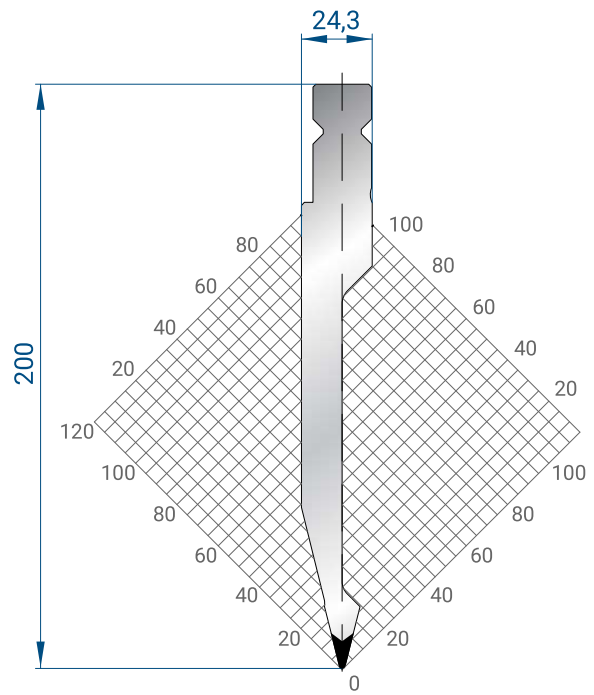

### 1326

**Mat** = 42 CrMo4  
 bonificato / tempered  
**H** = 200.00  
**Max T/m** = 80  
 $\alpha$  = 28°  
**R** = 1

515 mm	12,1 kg
200 mm	4,8 kg
100 mm	2,4 kg
550 mm	12,1 kg
FRAZ. / SECT.	



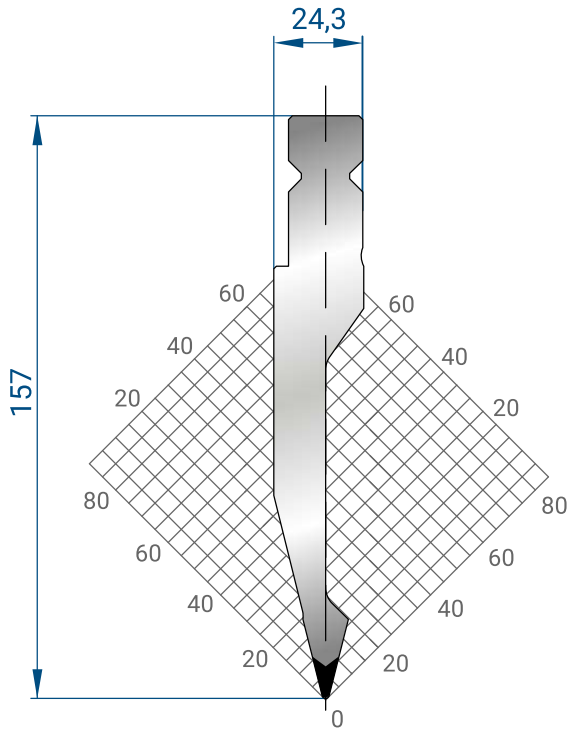

### 1337

**Mat** = 42 CrMo4  
 bonificato / *tempered*  
**H** = 157.00  
**Max T/m** = 100  
 $\alpha$  = 28°  
**R** = 1

515 mm	9,4 kg
200 mm	3,7 kg
100 mm	1,8 kg
550 mm	9,4 kg
FRAZ. / SECT.	

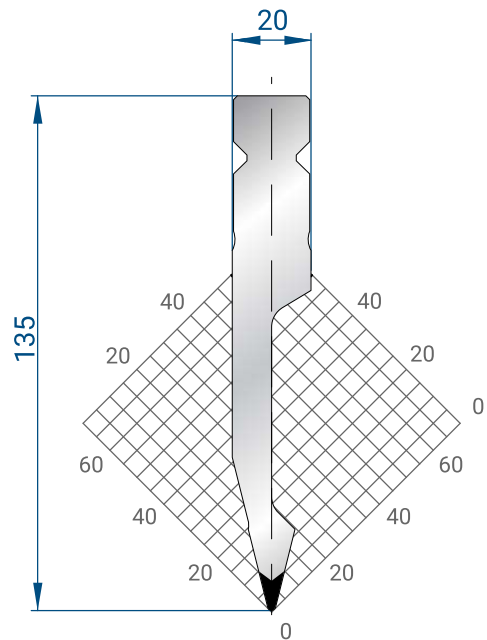

### 1325

**Mat** = 42 CrMo4  
 bonificato / *tempered*  
**H** = 135.00  
**Max T/m** = 100  
 $\alpha$  = 28°  
**R** = 1

515 mm	7,2 kg
200 mm	2,8 kg
100 mm	1,4 kg
550 mm	7,3 kg
FRAZ. / SECT.	





WILA STYLE



 EUROSTAMP TOOLING  
FOR THE BEST SOLUTIONS

132T A30 L18  
R1 W27 M7

VEDI PAG. 148 PER SCHEMA FRAZIONATURA PUNZONI  
SEE PAGE 148 FOR PUNCHES SEGMENTATION DIAGRAM

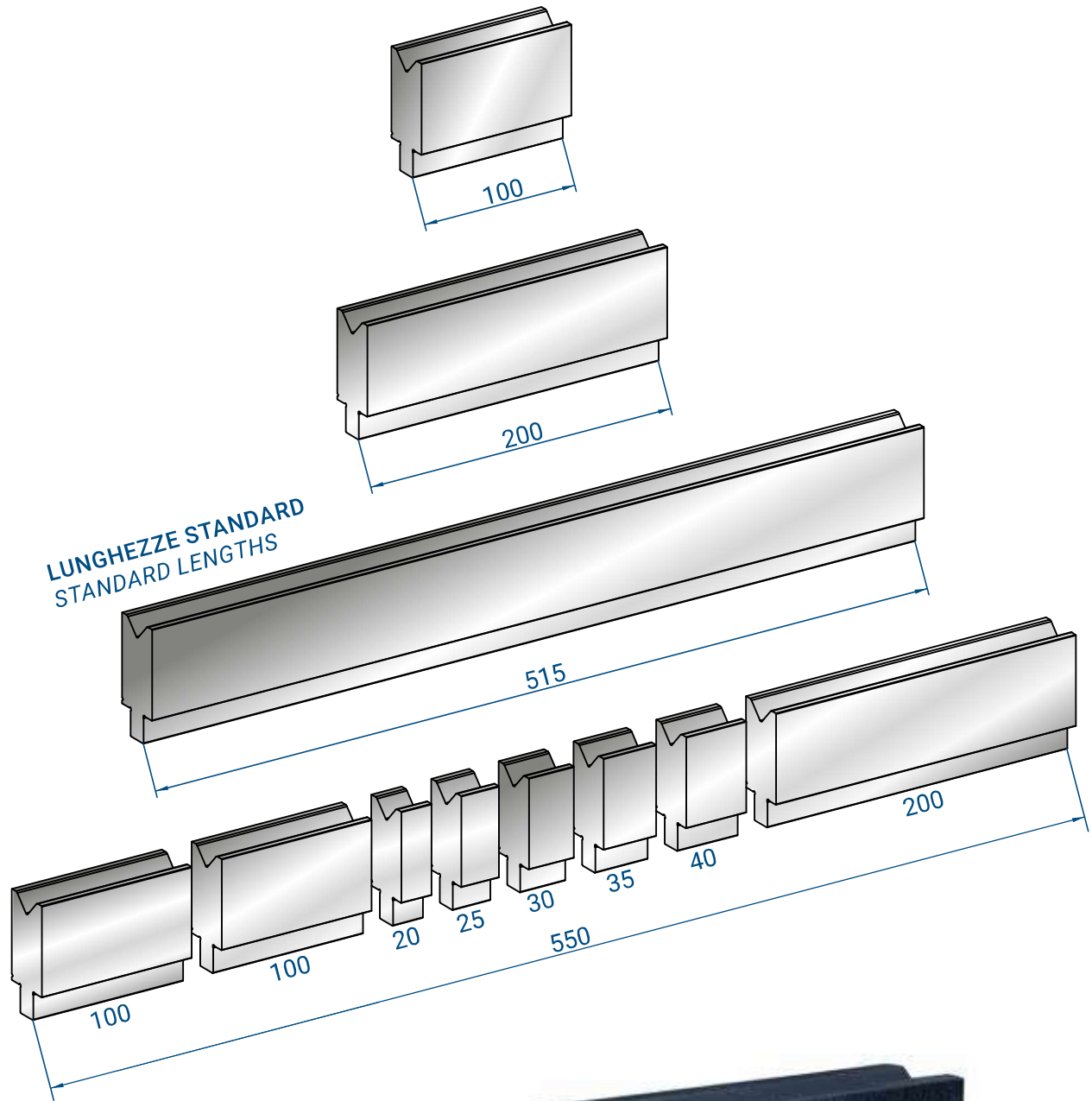

MODIFICHE A RICHIESTA  
MODIFICATIONS ON REQUEST

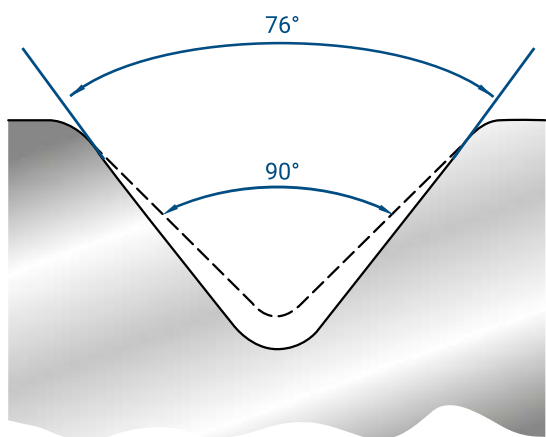
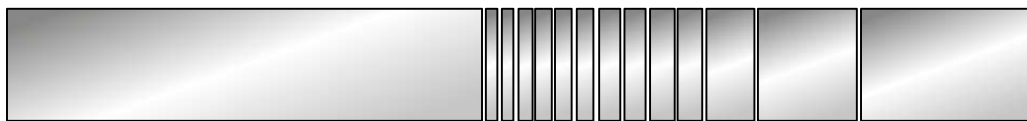

**MODIFICA ANGOLO**  
*ANGLE MODIFICATION*

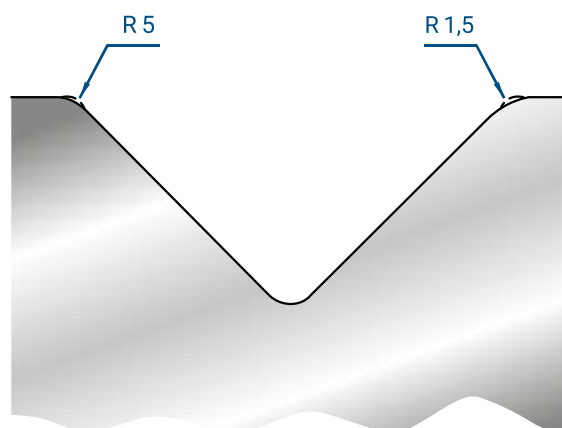

**MODIFICA RAGGIO**  
*RADIUS MODIFICATION*



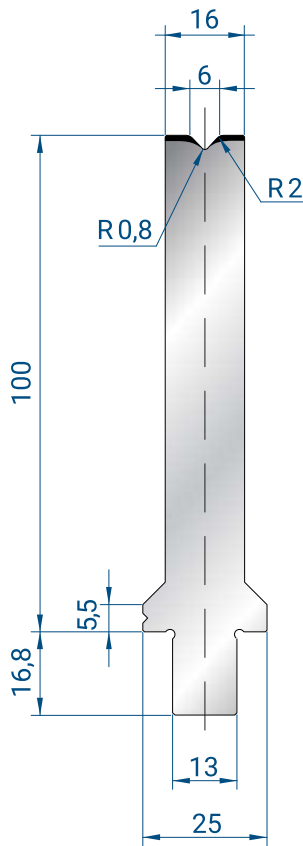

### 3270

**Mat** = 42 CrMo4  
 bonificato / *tempered*  
**H** = 100.00  
**Max T/m** = 120  
 $\alpha$  = 86°

515 mm	7,6 kg
200 mm	3,0 kg
100 mm	1,5 kg
550 mm	8,1 kg
FRAZ. / SECT	

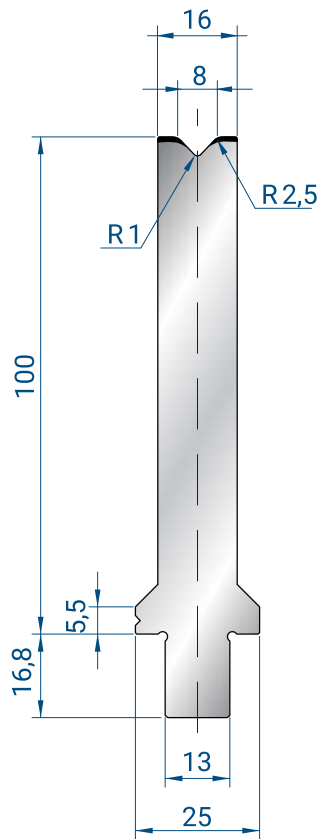

### 3271

**Mat** = 42 CrMo4  
 bonificato / *tempered*  
**H** = 100.00  
**Max T/m** = 120  
 $\alpha$  = 86°

515 mm	7,6 kg
200 mm	3,0 kg
100 mm	1,5 kg
550 mm	8,1 kg
FRAZ. / SECT	

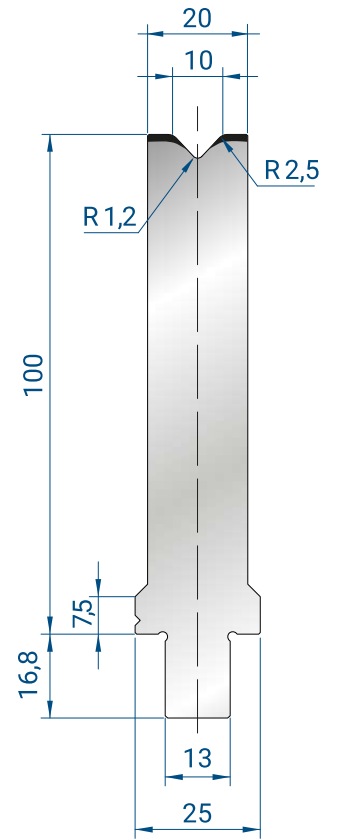

### 3272

**Mat** = 42 CrMo4  
 bonificato / *tempered*  
**H** = 100.00  
**Max T/m** = 120  
 $\alpha$  = 86°

515 mm	7,6 kg
200 mm	3,0 kg
100 mm	1,5 kg
550 mm	8,1 kg
FRAZ. / SECT	



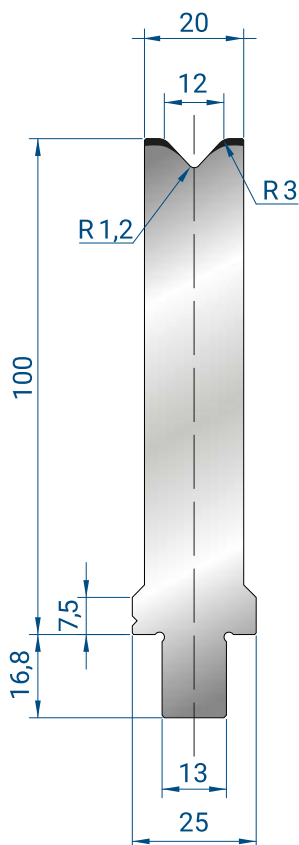

### 3273

**Mat** = 42 CrMo4  
 bonificato / tempered  
**H** = 100.00  
**Max T/m** = 120  
 $\alpha$  = 86°

515 mm	9,0 kg
200 mm	3,6 kg
100 mm	1,8 kg
550 mm	9,6 kg
FRAZ. / SECT	

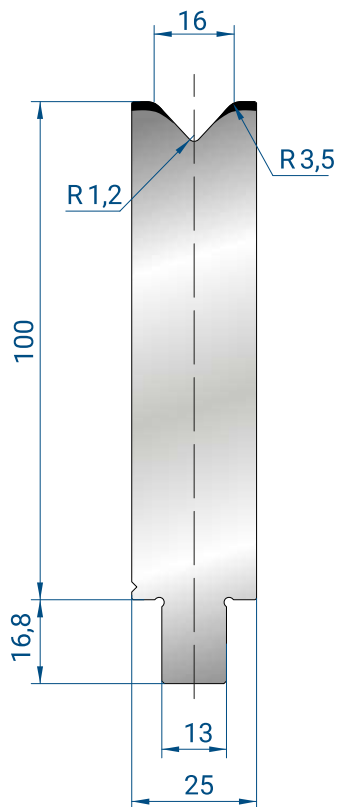

### 3274

**Mat** = 42 CrMo4  
 bonificato / tempered  
**H** = 100.00  
**Max T/m** = 120  
 $\alpha$  = 86°

515 mm	10,7 kg
200 mm	4,2 kg
100 mm	2,1 kg
550 mm	11,4 kg
FRAZ. / SECT	

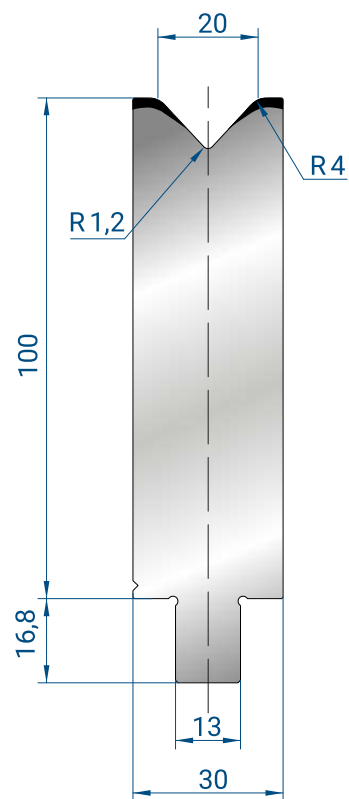

### 3275

**Mat** = 42 CrMo4  
 bonificato / tempered  
**H** = 100.00  
**Max T/m** = 120  
 $\alpha$  = 86°

515 mm	12,6 kg
200 mm	4,8 kg
100 mm	2,4 kg
550 mm	13,4 kg
FRAZ. / SECT	



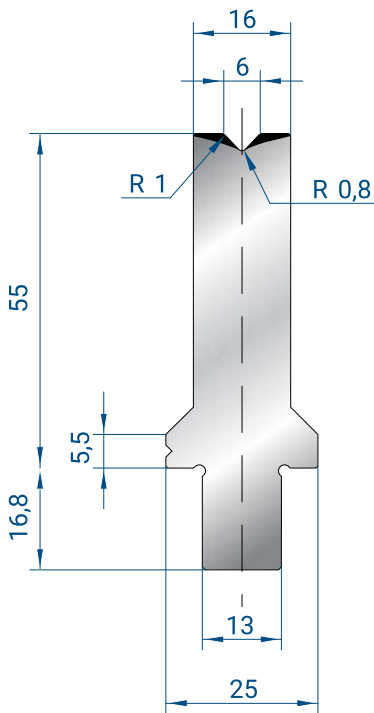

### 3250

**Mat** = 42 CrMo4  
 bonificato / *tempered*  
**H** = 55.00  
**Max T/m** = 120  
 $\alpha$  = 86°

515 mm	4,7 kg
200 mm	1,8 kg
100 mm	0,9 kg
550 mm	5,0 kg
FRAZ. / SECT	

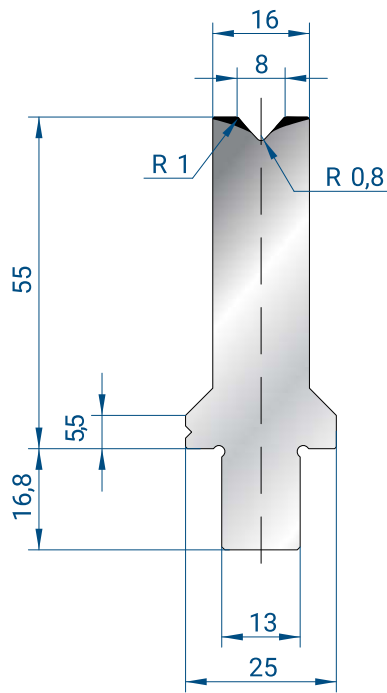

### 3251

**Mat** = 42 CrMo4  
 bonificato / *tempered*  
**H** = 55.00  
**Max T/m** = 120  
 $\alpha$  = 86°

515 mm	4,6 kg
200 mm	1,8 kg
100 mm	0,9 kg
550 mm	4,9 kg
FRAZ. / SECT	

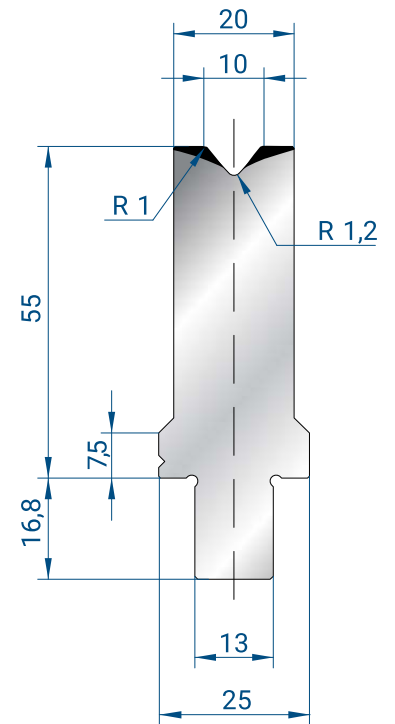

### 3252

**Mat** = 42 CrMo4  
 bonificato / *tempered*  
**H** = 55.00  
**Max T/m** = 120  
 $\alpha$  = 86°

515 mm	5,4 kg
200 mm	2,0 kg
100 mm	1,0 kg
550 mm	5,7 kg
FRAZ. / SECT	



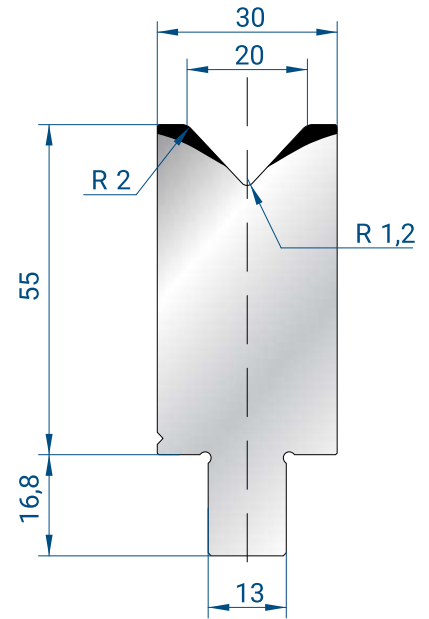
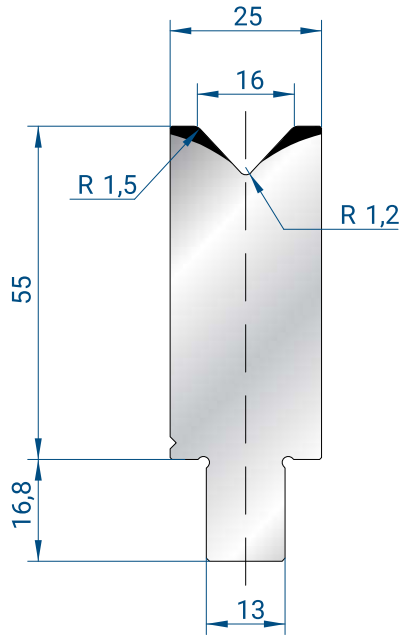
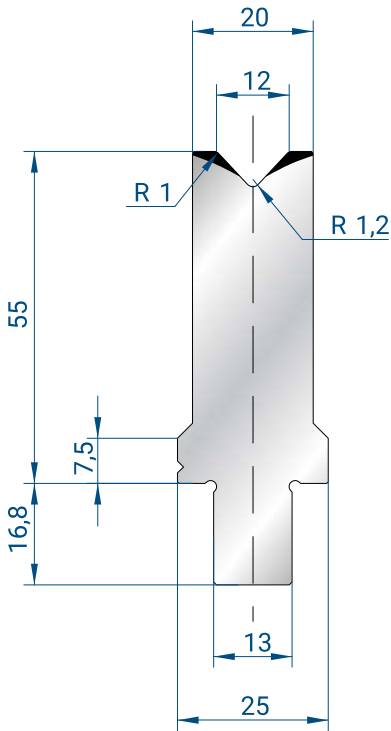

### 3253

**Mat** = 42 CrMo4  
 bonificato / *tempered*  
**H** = 55.00  
**Max T/m** = 120  
 $\alpha$  = 86°

515 mm	5,3 kg
200 mm	2,0 kg
100 mm	1,0 kg
550 mm	5,7 kg
FRAZ. / SECT	

### 3254

**Mat** = 42 CrMo4  
 bonificato / *tempered*  
**H** = 55.00  
**Max T/m** = 120  
 $\alpha$  = 86°

515 mm	6,1 kg
200 mm	2,4 kg
100 mm	1,2 kg
550 mm	6,6 kg
FRAZ. / SECT	

### 3255

**Mat** = 42 CrMo4  
 bonificato / *tempered*  
**H** = 55.00  
**Max T/m** = 120  
 $\alpha$  = 86°

515 mm	7,1 kg
200 mm	2,75 kg
100 mm	1,37 kg
550 mm	7,7 kg
FRAZ. / SECT	



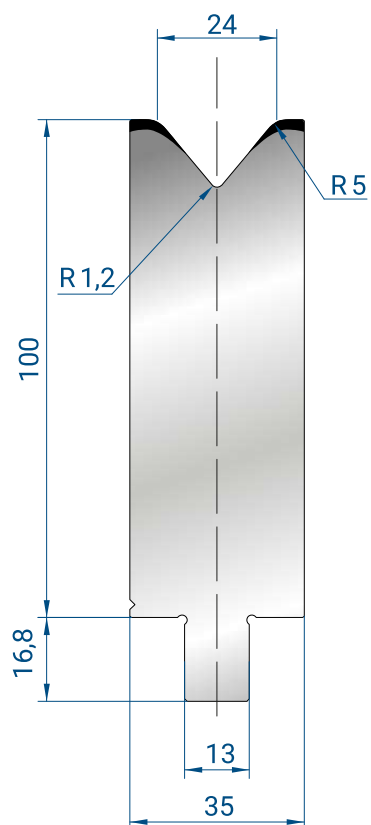

## 3276

**Mat** = 42 CrMo4  
 bonificato / *tempered*  
**H** = 100.00  
**Max T/m** = 125  
**α** = 80°

515 mm	14,3 kg
200 mm	5,6 kg
100 mm	2,8 kg
550 mm	15,3 kg
FRAZ. / SECT	



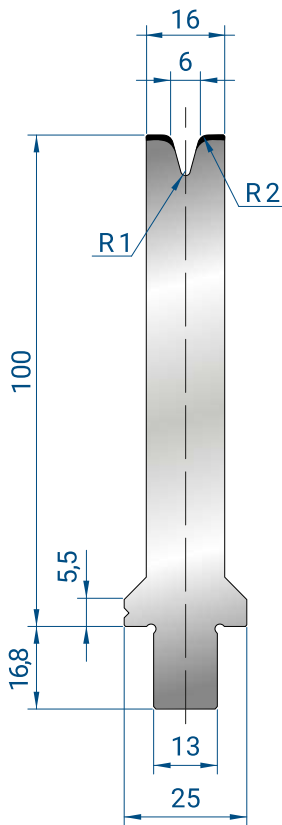

### 3280

**Mat** = 42 CrMo4  
 bonificato / tempered  
**H** = 100.00  
**Max T/m** = 40  
 $\alpha$  = 30°

515 mm	7,5 kg
200 mm	2,9 kg
100 mm	1,5 kg
550 mm	8,0 kg
FRAZ. / SECT	

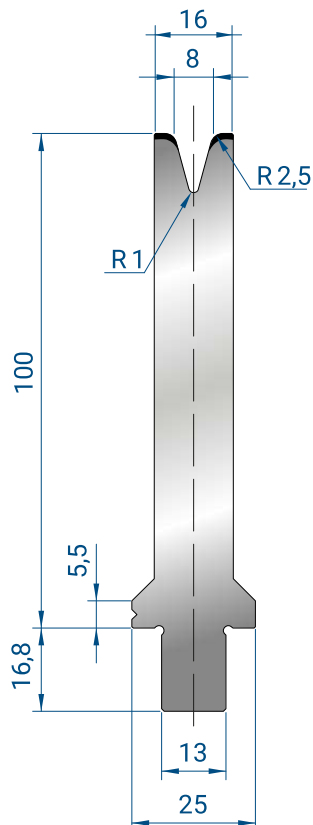

### 3281

**Mat** = 42 CrMo4  
 bonificato / tempered  
**H** = 100.00  
**Max T/m** = 35  
 $\alpha$  = 30°

515 mm	7,4 kg
200 mm	2,8 kg
100 mm	1,4 kg
550 mm	7,9 kg
FRAZ. / SECT	

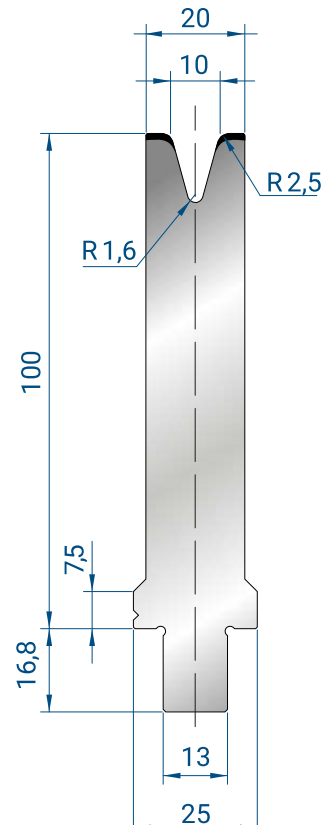

### 3282

**Mat** = 42 CrMo4  
 bonificato / tempered  
**H** = 100.00  
**Max T/m** = 55  
 $\alpha$  = 30°

515 mm	8,8 kg
200 mm	3,4 kg
100 mm	1,7 kg
550 mm	9,4 kg
FRAZ. / SECT	

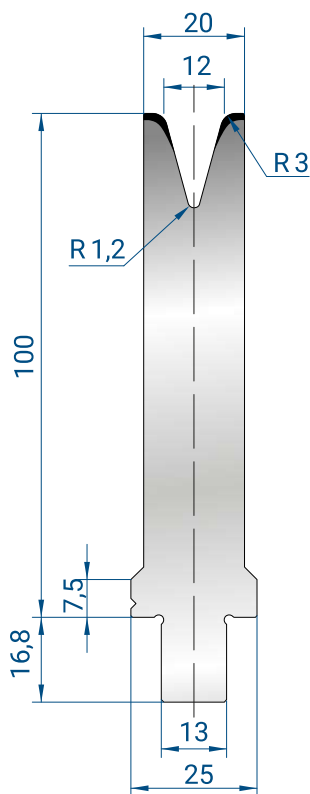

### 3283

**Mat** = 42 CrMo4  
 bonificato / *tempered*  
**H** = 100.00  
**Max T/m** = 40  
 $\alpha$  = 30°

515 mm	8,6 kg
200 mm	3,3 kg
100 mm	1,7 kg
550 mm	9,2 kg
FRAZ. / SECT	

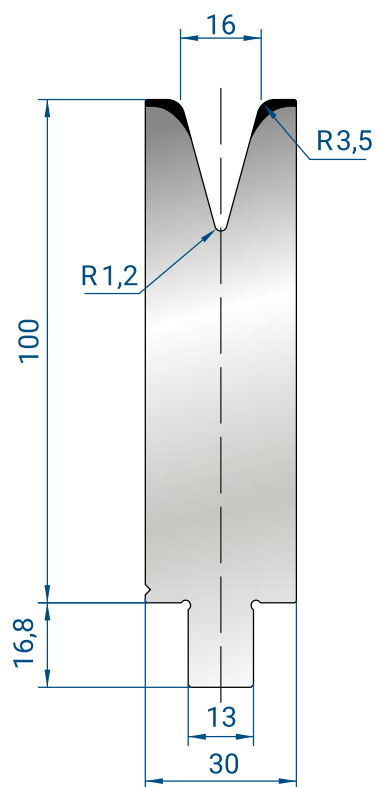

### 3284

**Mat** = 42 CrMo4  
 bonificato / *tempered*  
**H** = 100.00  
**Max T/m** = 60  
 $\alpha$  = 30°

515 mm	12,0 kg
200 mm	4,7 kg
100 mm	2,3 kg
550 mm	12,9 kg
FRAZ. / SECT	



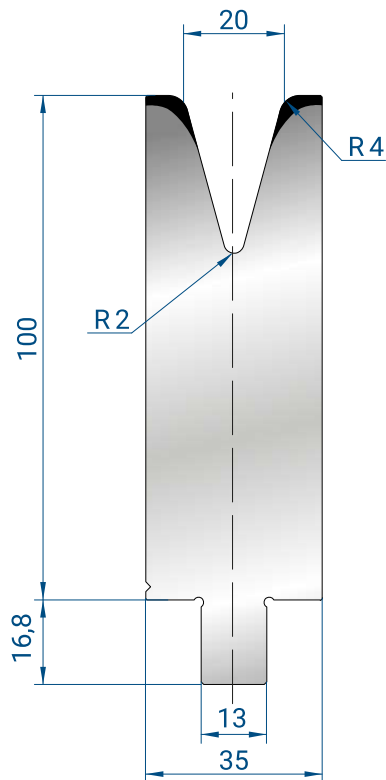

### 3285

**Mat** = 42 CrMo4  
 bonificato / *tempered*  
**H** = 100.00  
**Max T/m** = 55  
 $\alpha$  = 30°

515 mm	13,6 kg
200 mm	5,3 kg
100 mm	2,6 kg
550 mm	14,5 kg
FRAZ. / SECT	

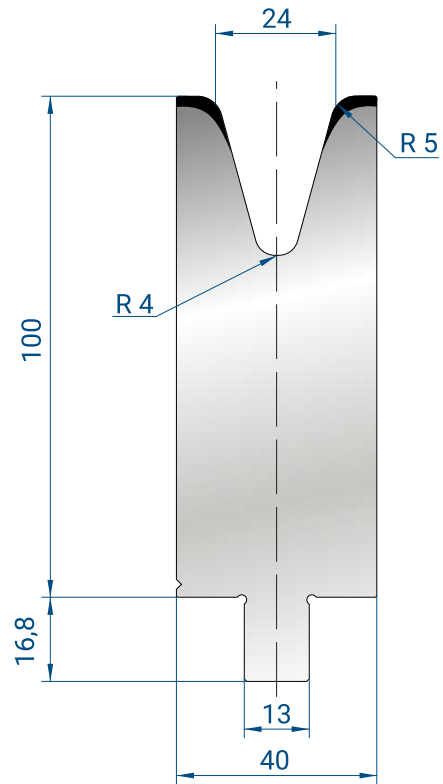

### 3286

**Mat** = 42 CrMo4  
 bonificato / *tempered*  
**H** = 100.00  
**Max T/m** = 45  
 $\alpha$  = 30°

515 mm	15,1 kg
200 mm	5,8 kg
100 mm	2,9 kg
550 mm	16,1 kg
FRAZ. / SECT	



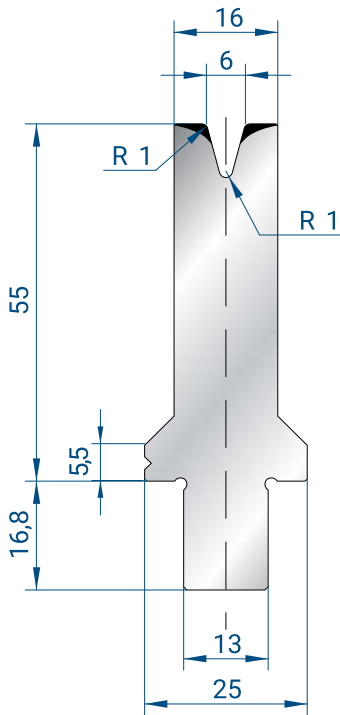

### 3260

**Mat** = 42 CrMo4  
 bonificato / *tempered*  
**H** = 55.00  
**Max T/m** = 40  
 $\alpha$  = 30°

515 mm	4,6 kg
200 mm	1,8 kg
100 mm	0,9 kg
550 mm	4,9 kg
FRAZ. / SECT	

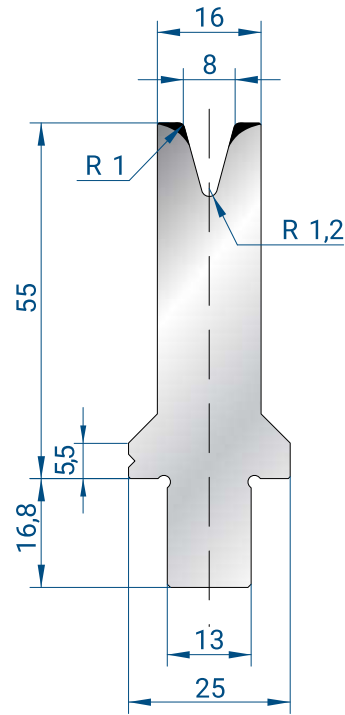

### 3261

**Mat** = 42 CrMo4  
 bonificato / *tempered*  
**H** = 55.00  
**Max T/m** = 35  
 $\alpha$  = 30°

515 mm	4,5 kg
200 mm	1,8 kg
100 mm	0,9 kg
550 mm	4,8 kg
FRAZ. / SECT	

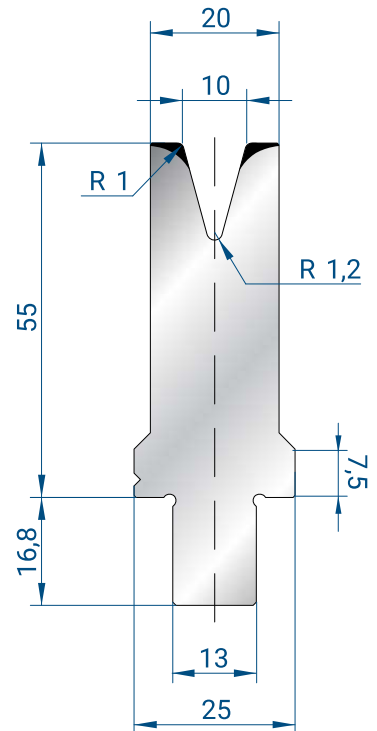

### 3262

**Mat** = 42 CrMo4  
 bonificato / *tempered*  
**H** = 55.00  
**Max T/m** = 55  
 $\alpha$  = 30°

515 mm	5,1 kg
200 mm	2,0 kg
100 mm	1,0 kg
550 mm	5,5 kg
FRAZ. / SECT	



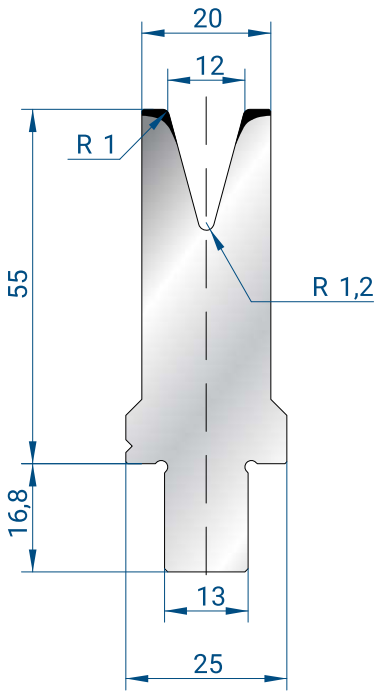

### 3263

**Mat** = 42 CrMo4  
 bonificato / *tempered*  
**H** = 55.00  
**Max T/m** = 40  
 $\alpha$  = 30°

515 mm	5,0 kg
200 mm	2,0 kg
100 mm	1,0 kg
550 mm	5,3 kg
FRAZ. / SECT	

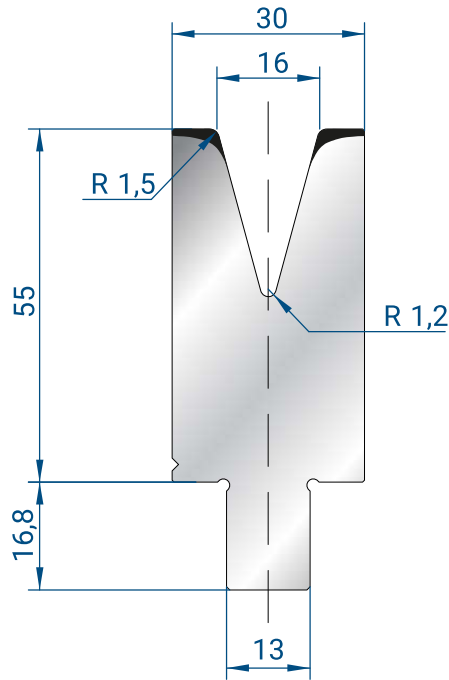

### 3264

**Mat** = 42 CrMo4  
 bonificato / *tempered*  
**H** = 55.00  
**Max T/m** = 60  
 $\alpha$  = 30°

515 mm	6,6 kg
200 mm	2,6 kg
100 mm	1,3 kg
550 mm	7,0 kg
FRAZ. / SECT	

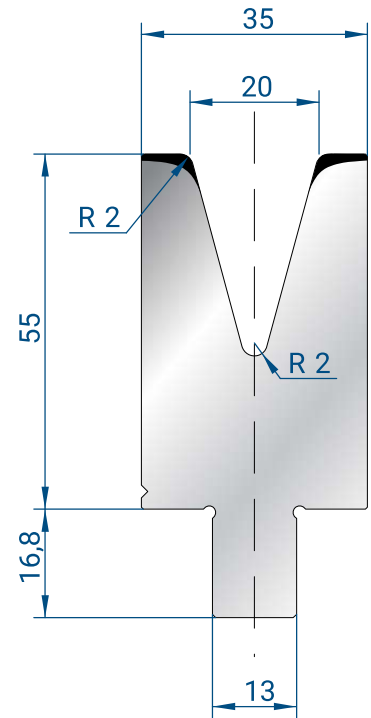

### 3265

**Mat** = 42 CrMo4  
 bonificato / *tempered*  
**H** = 55.00  
**Max T/m** = 55  
 $\alpha$  = 30°

515 mm	7,2 kg
200 mm	2,8 kg
100 mm	1,4 kg
550 mm	7,7 kg
FRAZ. / SECT	



**EUROSTAMP** TOOLING  
the Italian excellence

# BYSTRONIC STYLE

**Gli utensili superiori e inferiori elencati in questa sezione possono essere installati sulle piegatrici Bystronic/Beyeler dotate dei seguenti tipi di bloccaggio:**

Bystronic/Beyeler Type RFA  
Bystronic/Beyeler Type RF  
Bystronic/Beyeler Type R

Questi utensili possono essere installati anche su altre piegatrici tramite adattatori superiori e inferiori.

***Upper and lower tooling listed on this section could be installed on the Bystronic/Beyeler press brakes equipped with the following clamping types:***

*Bystronic/Beyeler Type RFA  
Bystronic/Beyeler Type RF  
Bystronic/Beyeler Type R*

*These tooling could also be installed on other press brakes by using the appropriate upper and lower adapters.*





2000  
**EUROSTAMP**  
the Italian excellence

VEDI PAG. 181 PER SCHEMA FRAZIONATURA MATRICI  
 SEE PAGE 181 FOR DIE SEGMENTATION DIAGRAM

FRAZIONATURA STANDARD  
 STANDARD SEGMENTATION

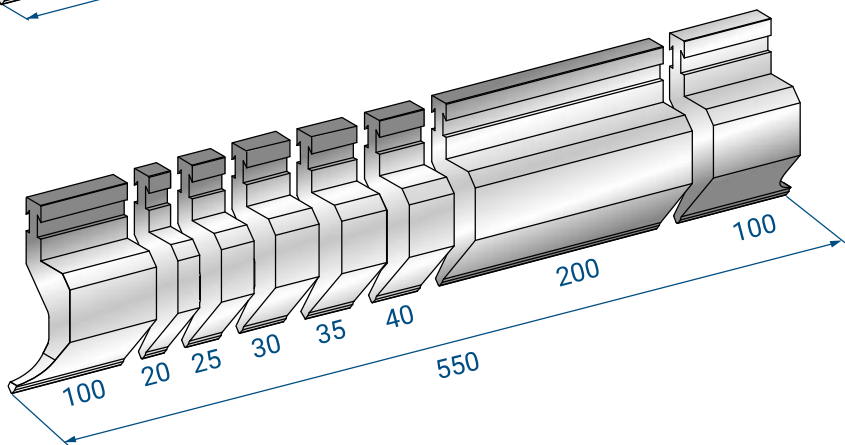
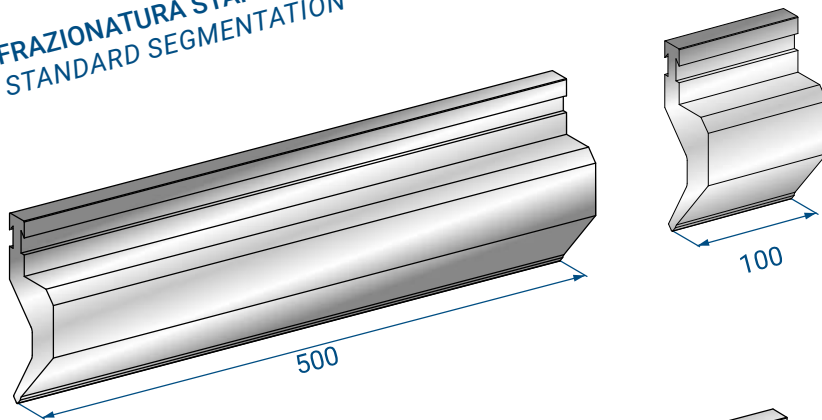

FRESATURA SCARPETTA  
 MILLED HORN

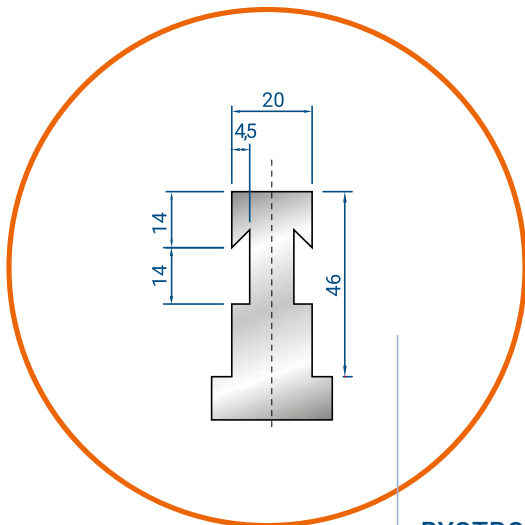
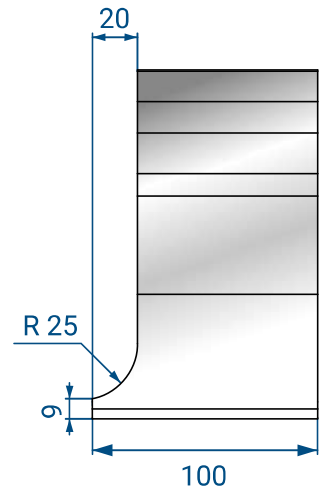

BYSTRONIC STYLE  
 TYPE R

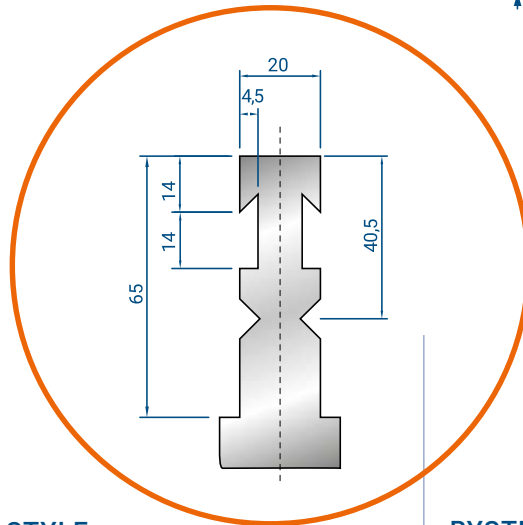

BYSTRONIC STYLE  
 TYPE RF-A

INCLUSO SU RICHIESTA  
 AVAILABLE ON DEMAND  
 AT NO COST

CODICE / CODE **8022**

SCARPETTE SPECIALI  
SPECIAL HORNS

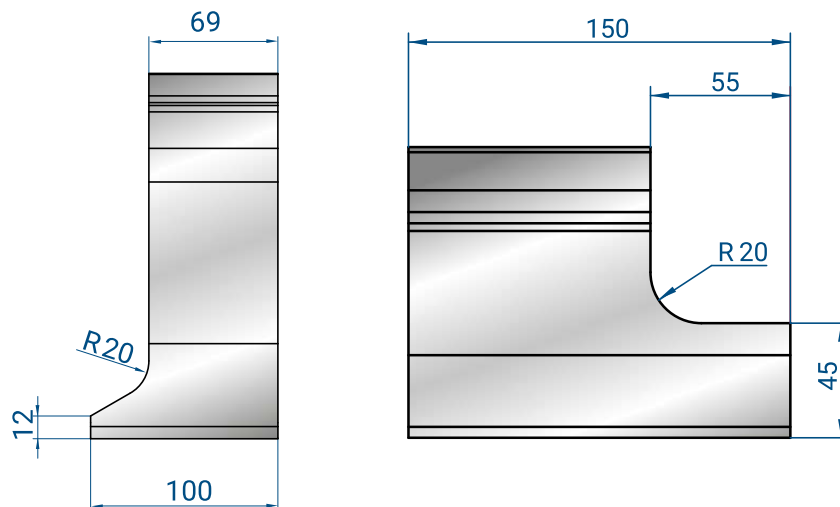

TAGLI A RICHIESTA  
SPECIAL SEGMENTATION

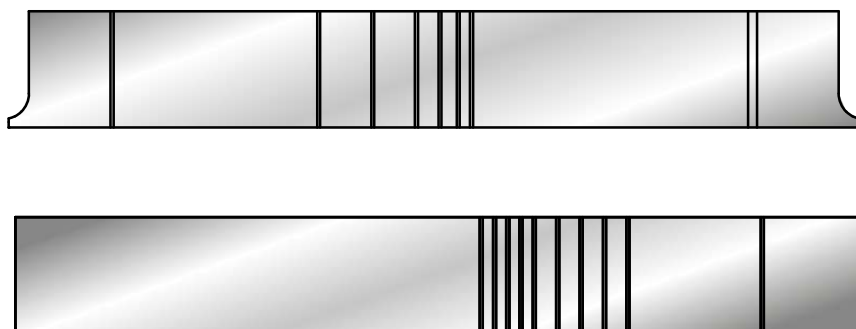

MODIFICA RAGGIO  
RADIUS MODIFICATION

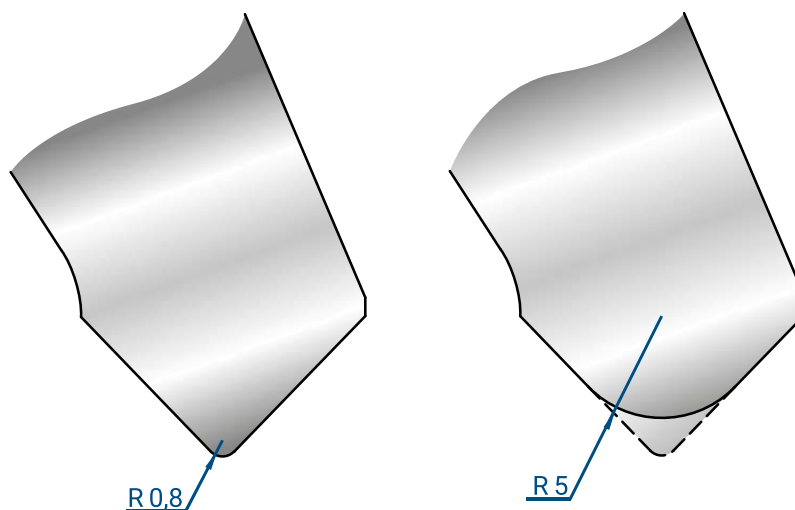

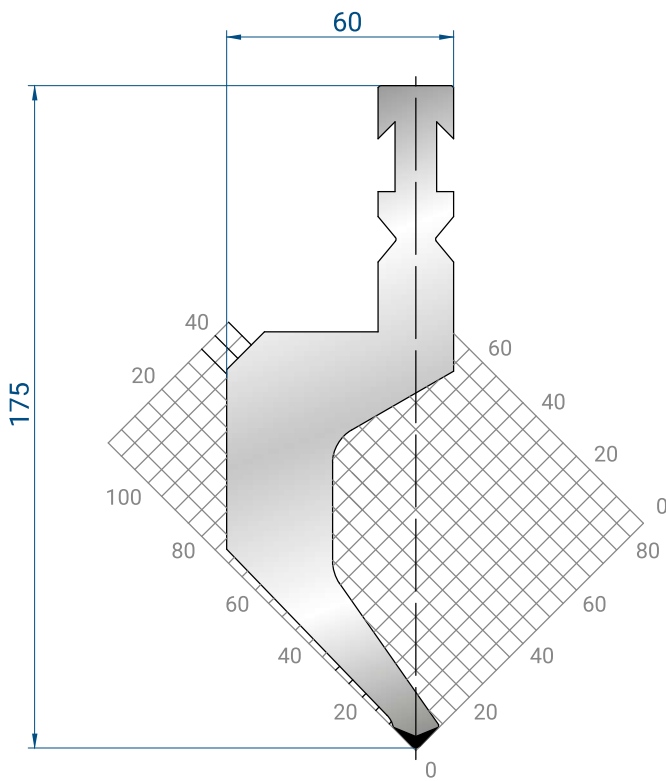

**1227**

**Mat** = C45  
 bonificato / *tempered*  
**H** = 175.00  
**Max T/m** = 50  
 $\alpha$  = 88°  
**R** = 1.5

500 mm	16,3 kg
550 mm SECT. SHORT	16,6 kg
100 mm	3,3 kg

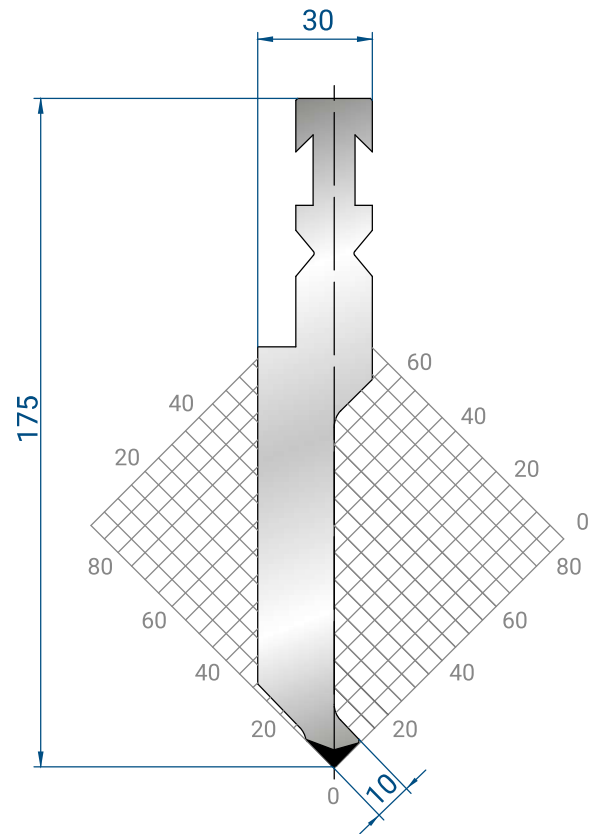

**1229**

**Mat** = C45  
 bonificato / *tempered*  
**H** = 175.00  
**Max T/m** = 100  
 $\alpha$  = 88°  
**R** = 1

500 mm	12,8 kg
550 mm SECT. SHORT	13,0 kg
100 mm	2,6 kg

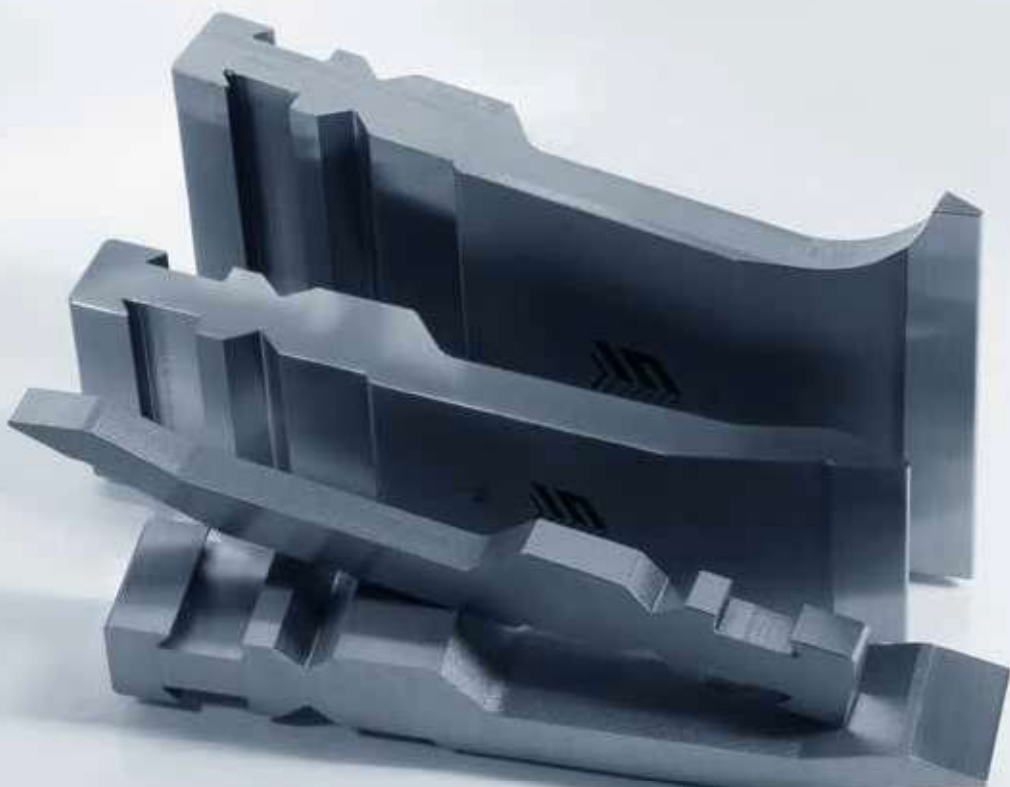

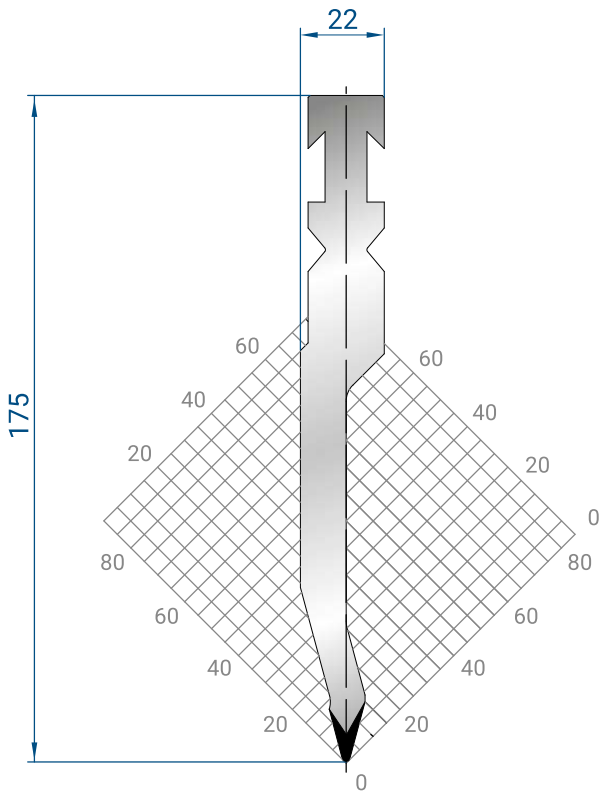

### 1230

Mat = C45  
 bonificato / *tempered*  
 H = 175.00  
 Max T/m = 80  
 $\alpha = 30^\circ$   
 R = 1

500 mm	9,1 kg
550 mm SECT. SHORT	9,3 kg
100 mm	1,8 kg

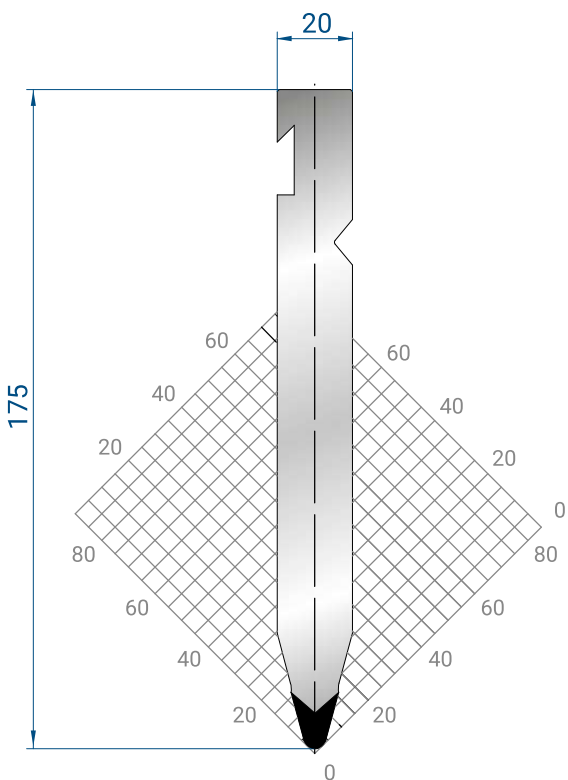

### 1231

Mat = C45  
 bonificato / *tempered*  
 H = 175.00  
 Max T/m = 100  
 $\alpha = 30^\circ$   
 R = 3

500 mm	12,4 kg
550 mm SECT. SHORT	12,7 kg
100 mm	2,5 kg

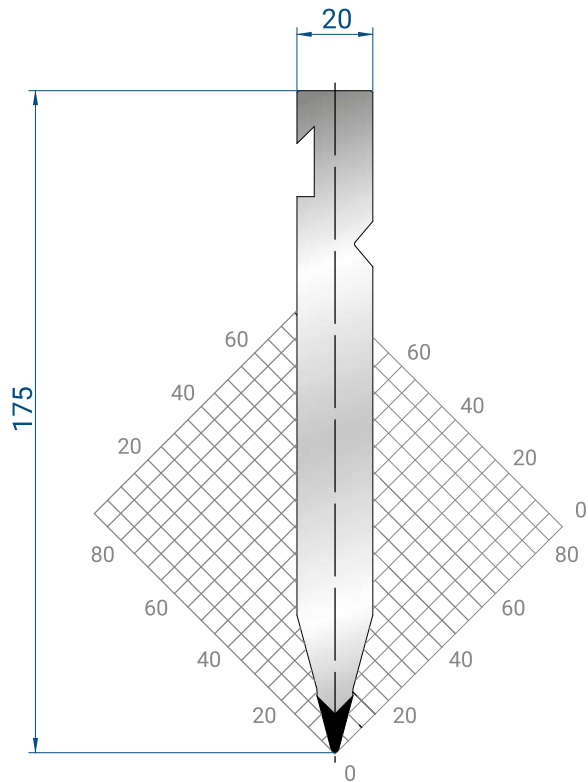

### 1232

Mat = C45  
 bonificato / *tempered*  
 H = 175.00  
 Max T/m = 100  
 $\alpha = 30^\circ$   
 R = 1

500 mm	12,0 kg
550 mm SECT. SHORT	12,2 kg
100 mm	2,4 kg

**1298**

**Mat** = 42 CrMo4  
 bonificato / *tempered*  
**H** = 250.00  
**Max T/m** = 60  
 **$\alpha$**  = 86°  
**R** = 1.5

500 mm	25,1 kg
550 mm SECT. SHORT	24,6 kg
100 mm	5,0 kg

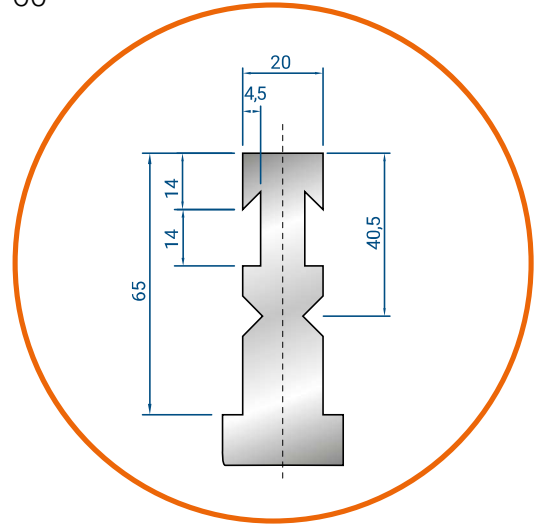
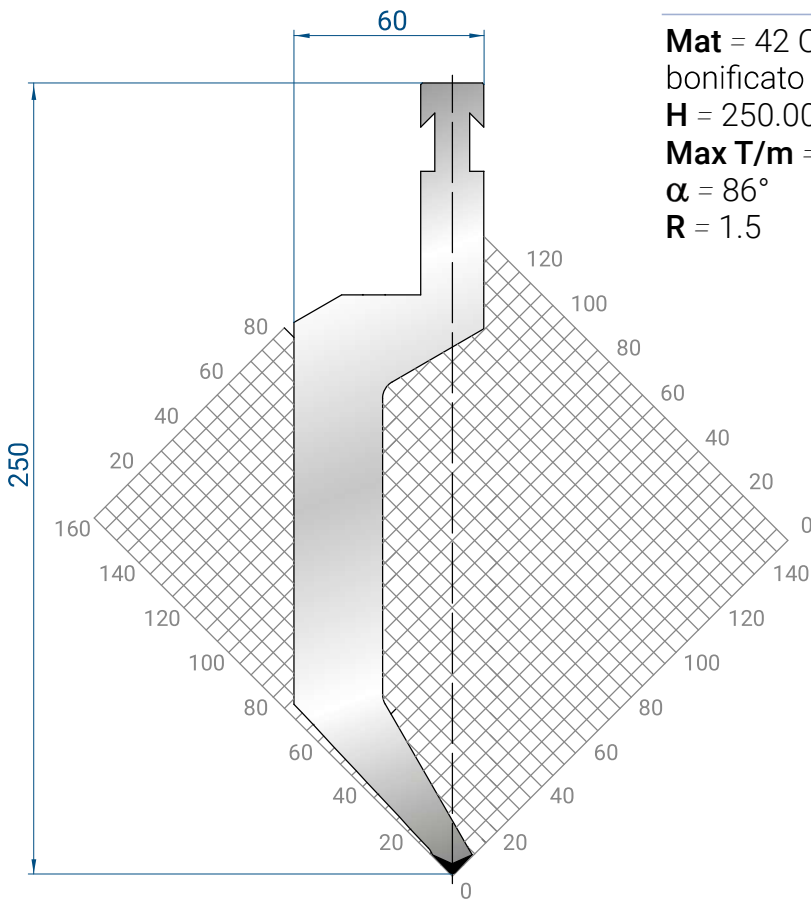

**ATTACCO / UPPER TANG RF-A**

INCLUSO SU RICHIESTA  
 AVAILABLE ON DEMAND  
 AT NO COST

CODICE / CODE **8022**



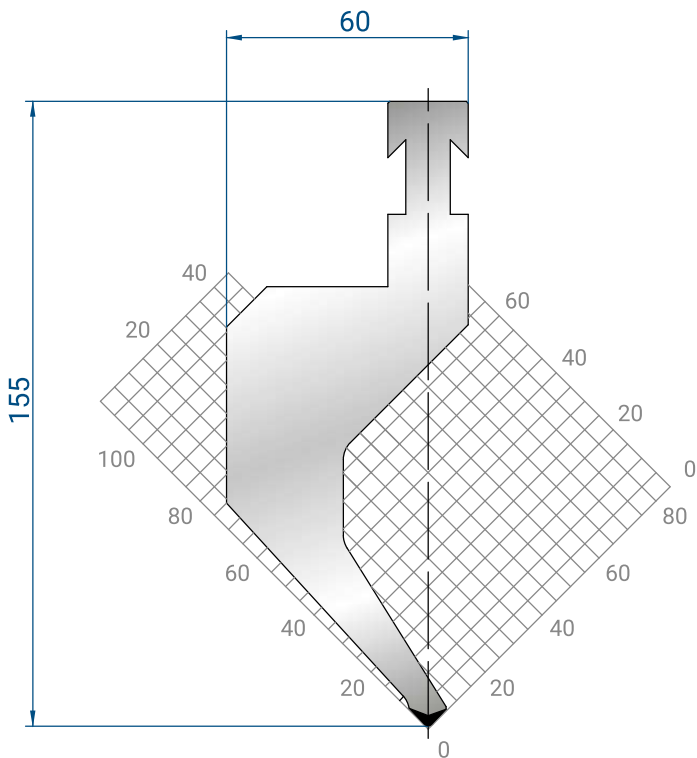

### 1216

**Mat** = C45  
 bonificato / *tempered*  
**H** = 155.00  
**Max T/m** = 50  
 $\alpha$  = 85°  
**R** = 1.5

500 mm	15,3 kg
550 mm SECT. SHORT	15,6 kg
100 mm	3,0 kg

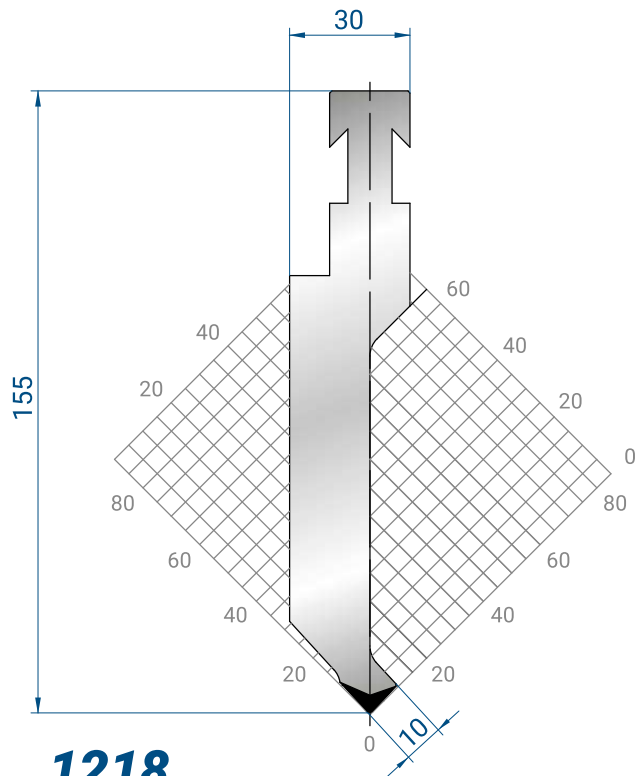

### 1218

**Mat** = C45  
 bonificato / *tempered*  
**H** = 155.00  
**Max T/m** = 100  
 $\alpha$  = 85°  
**R** = 1

500 mm	11,4 kg
550 mm SECT. SHORT	11,7 kg
100 mm	2,3 kg

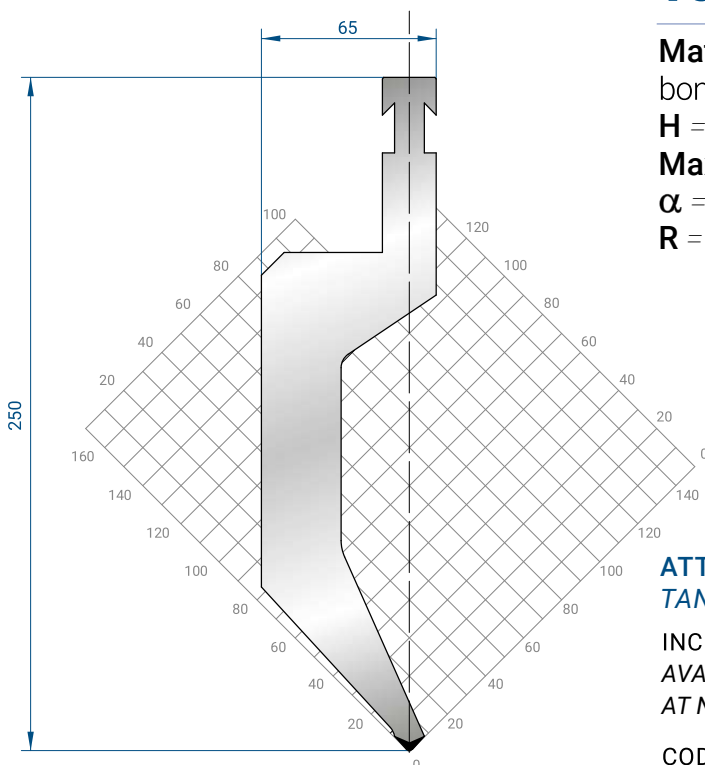

### 1321

**Mat** = 42 CrMo4  
 bonificato / *tempered*  
**H** = 250.00  
**Max T/m** = 100  
 $\alpha$  = 85°  
**R** = 1.5

500 mm	27,9 kg
550 mm SECT. SHORT	28,5 kg
100 mm	5,6 kg

#### ATTACCO / UPPER TANG RF-A

INCLUSO SU RICHIESTA  
 AVAILABLE ON DEMAND  
 AT NO COST

CODICE / CODE **8022**

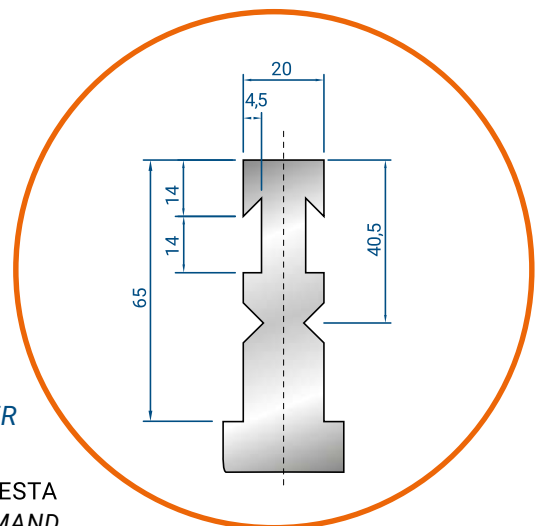

## 1299

550 mm	13,3 kg
500 mm SECT. SHORT	13,6 kg
100 mm	2,7 kg

Mat = 42 CrMo4  
 bonificato / *tempered*  
 H = 250.00  
 Max T/m = 80  
 $\alpha = 30^\circ$   
 R = 1

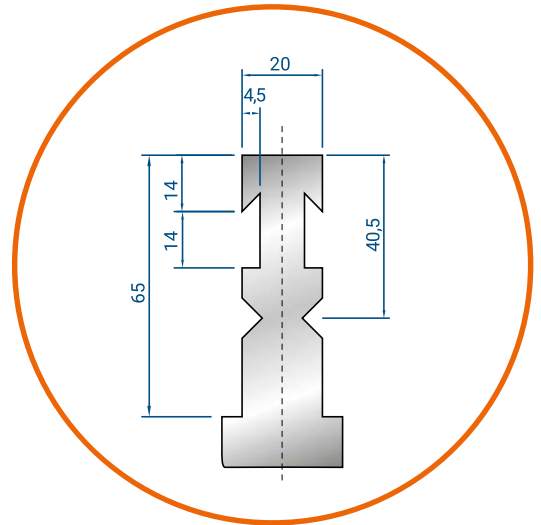
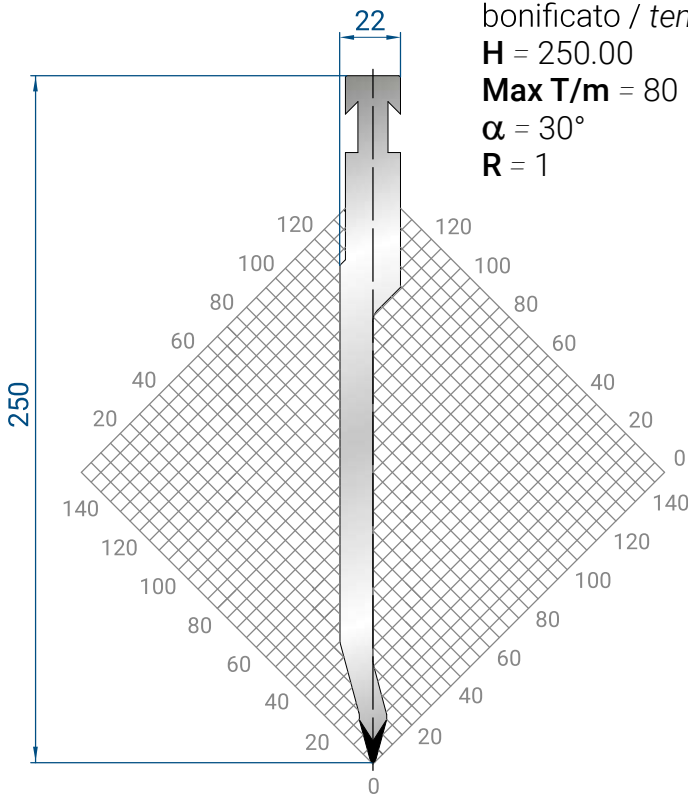

ATTACCO / UPPER TANG RF-A

INCLUSO SU RICHIESTA  
 AVAILABLE ON DEMAND  
 AT NO COST

CODICE / CODE **8022**

## 1300

500 mm	18,4 kg
550 mm SECT. SHORT	18,8 kg
100 mm	3,7 kg

Mat = 42CrMo4  
 bonificato / *tempered*  
 H = 250.00  
 Max T/m = 120  
 $\alpha = 30^\circ$   
 R = 3

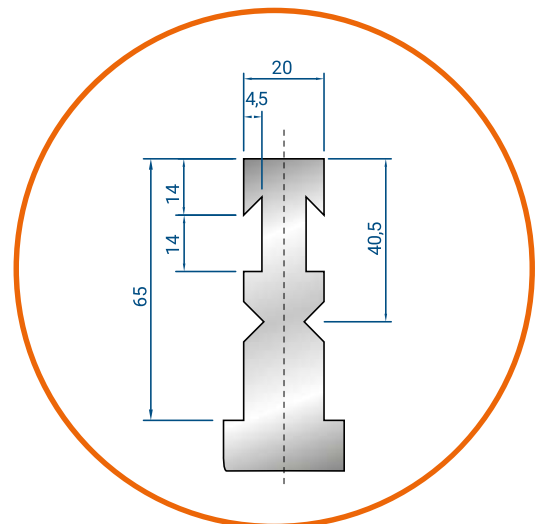
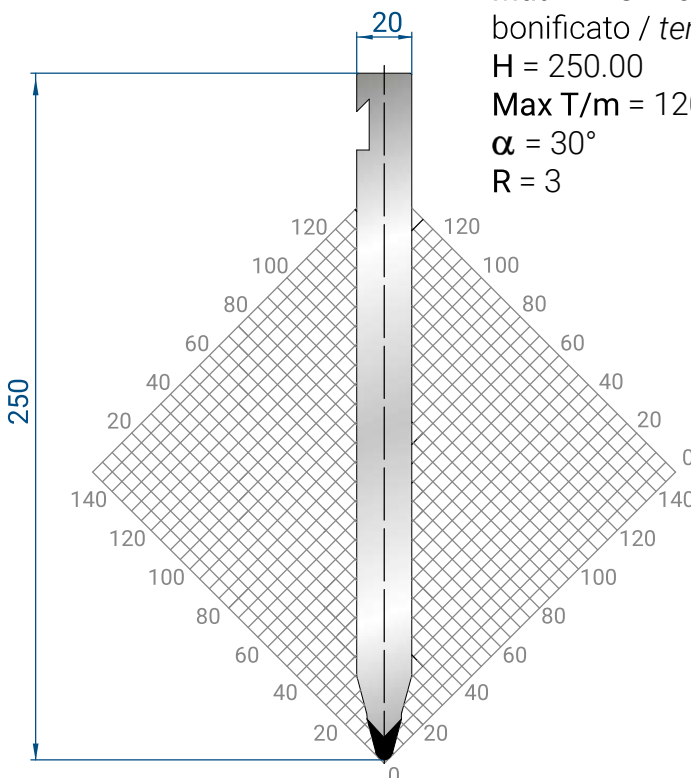

ATTACCO / UPPER TANG RF-A

INCLUSO SU RICHIESTA  
 AVAILABLE ON DEMAND  
 AT NO COST

CODICE / CODE **8022**

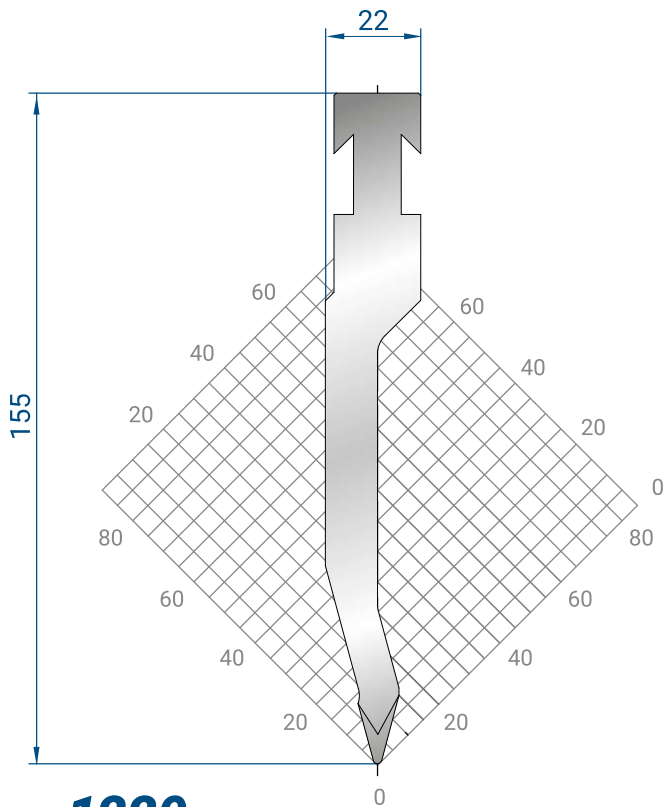

### 1220

Mat = C45  
 bonificato / *tempered*  
 H = 155.00  
 Max T/m = 80  
 $\alpha = 30^\circ$   
 R = 1

500 mm	7,8 kg
550 mm SECT. SHORT	7,9 kg
100 mm	1,6 kg

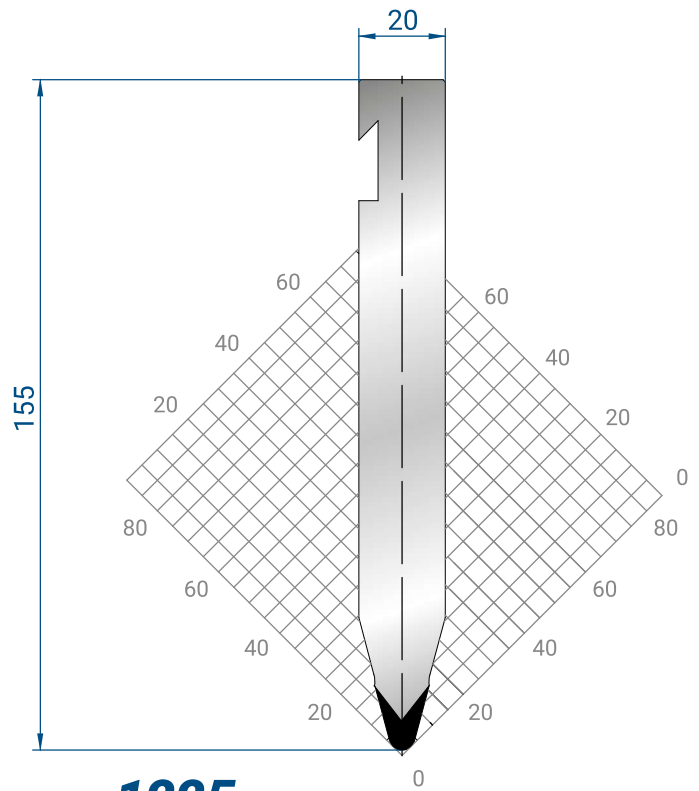

### 1225

Mat = C45  
 bonificato / *tempered*  
 H = 155.00  
 Max T/m = 100  
 $\alpha = 30^\circ$   
 R = 3

500 mm	10,9 kg
550 mm SECT. SHORT	11,2 kg
100 mm	2,2 kg



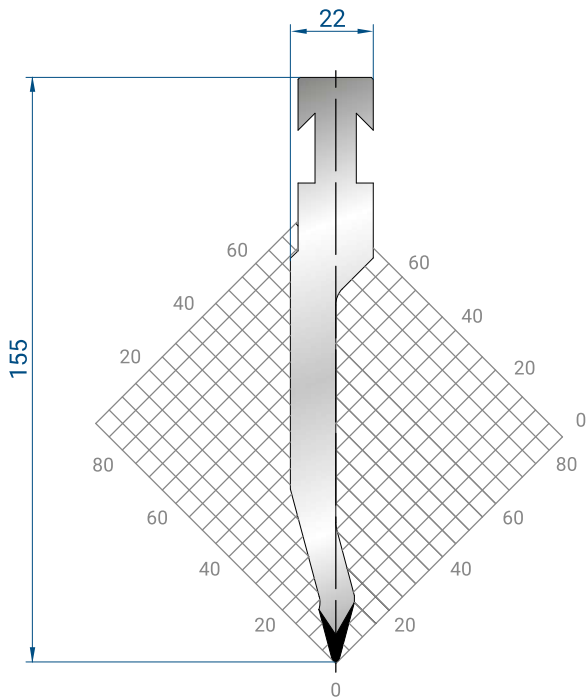

## 1221

Mat = C45  
 bonificato / *tempered*  
 H = 155.00  
 Max T/m = 80  
 $\alpha = 28^\circ$   
 R = 1

500 mm	7,8 kg
550 mm SECT. SHORT	7,9 kg
100 mm	1,6 kg



VEDI PAG. 172 PER SCHEMA FRAZIONATURA PUNZONI  
 SEE PAGE 172 FOR PUNCHES SEGMENTATION DIAGRAM

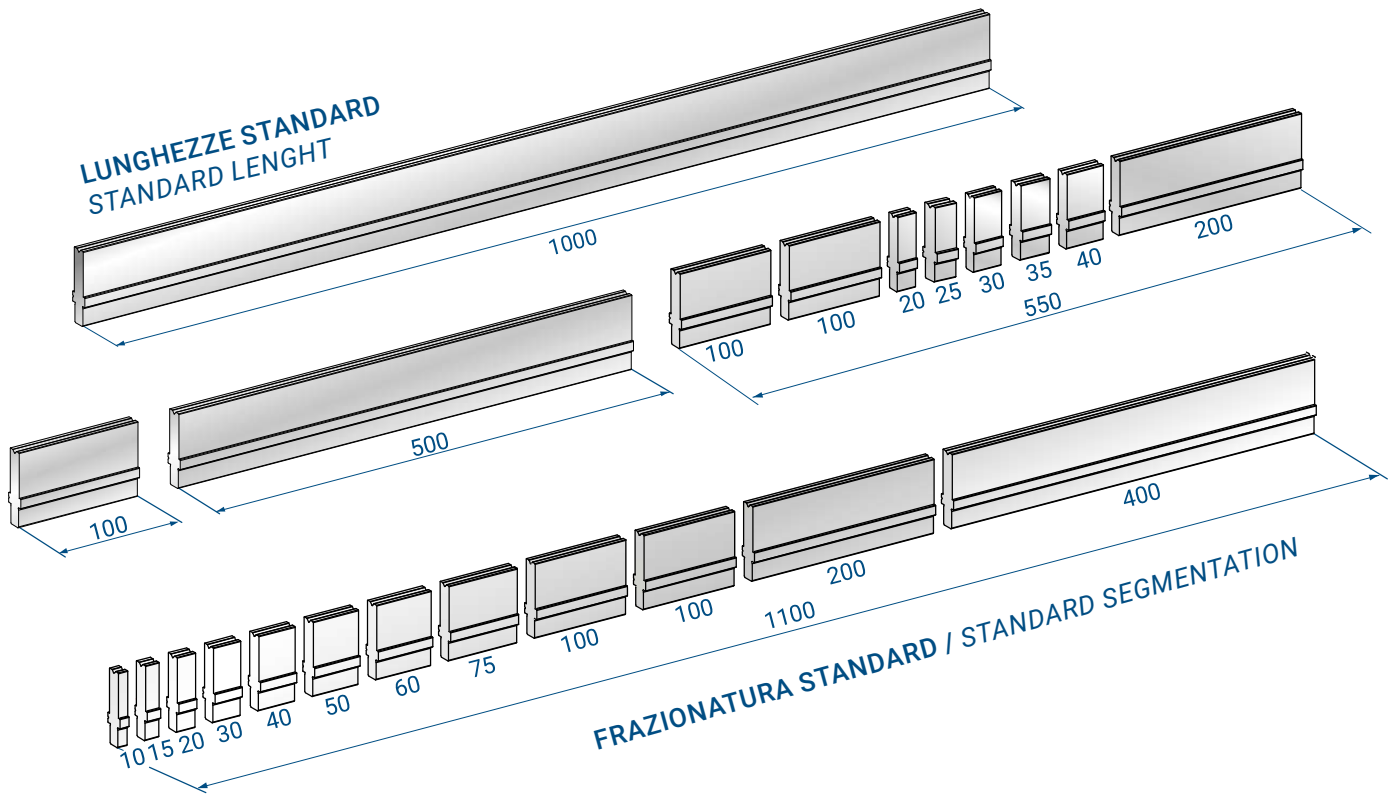

MODIFICHE A RICHIESTA  
 MODIFICATIONS ON REQUEST

TAGLI A RICHIESTA  
 SPECIAL SEGMENTATION

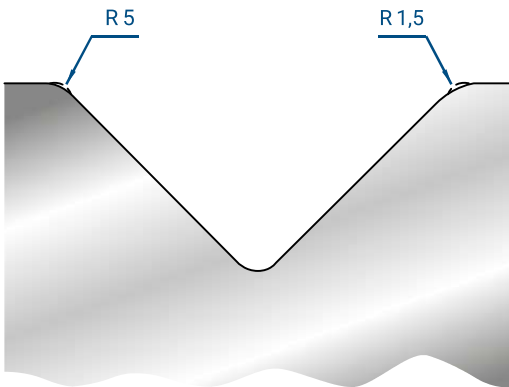
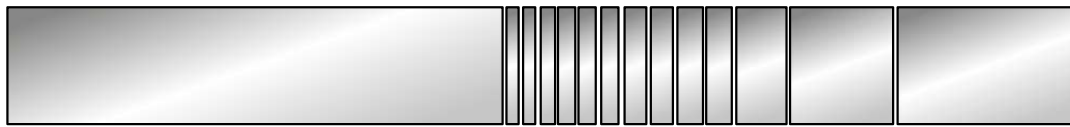

MODIFICA RAGGIO  
 RADIUS MODIFICATION

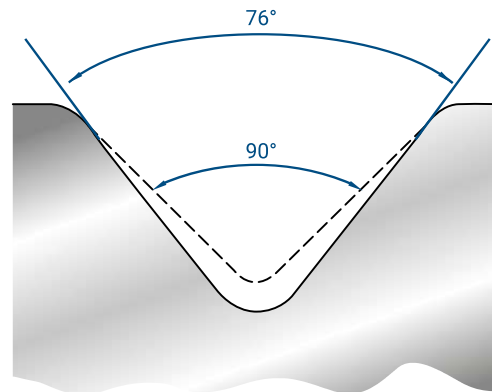

MODIFICA ANGOLO  
 ANGLE MODIFICATION

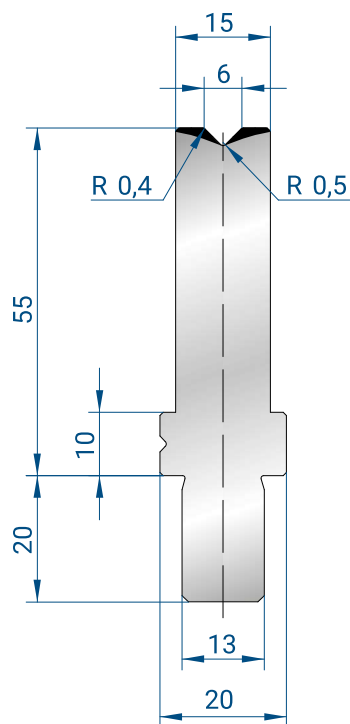

### 3241

Mat = C45  
 Max T/m = 100  
 $\alpha = 88^\circ$

1000 mm	8,7 kg
500 mm	4,4 kg
1100 mm FRAZ. / SECT.	9,7 kg
550 mm SECT. SHORT	4,8 kg
100 mm	0,9 kg

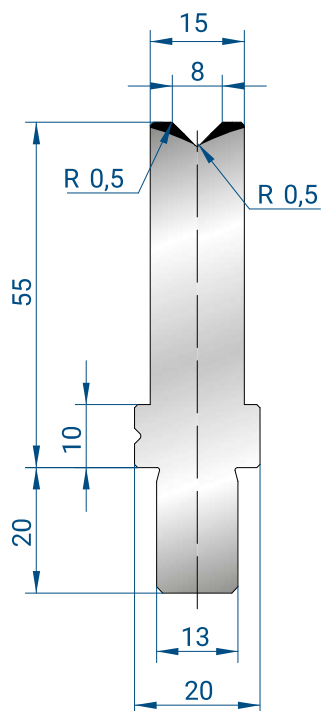

### 3242

Mat = C45  
 Max T/m = 100  
 $\alpha = 88^\circ$

1000 mm	8,7 kg
500 mm	4,4 kg
1100 mm FRAZ. / SECT.	9,6 kg
550 mm SECT. SHORT	4,8 kg
100 mm	0,9 kg

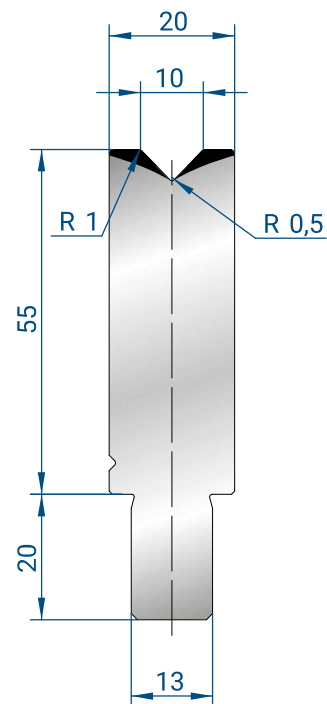

### 3106

Mat = C45  
 Max T/m = 100  
 $\alpha = 88^\circ$

1000 mm	10,4 kg
500 mm	5,2 kg
1100 mm FRAZ. / SECT.	11,5 kg
550 mm SECT. SHORT	5,7 kg
100 mm	1,0 kg



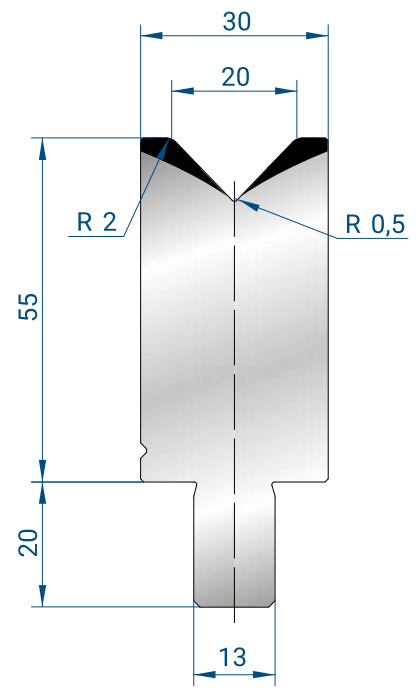
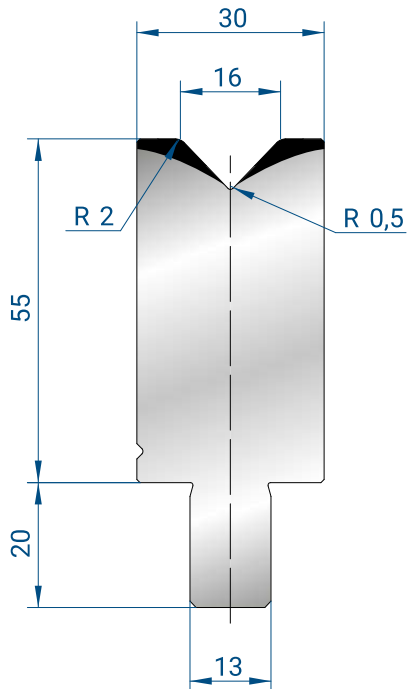
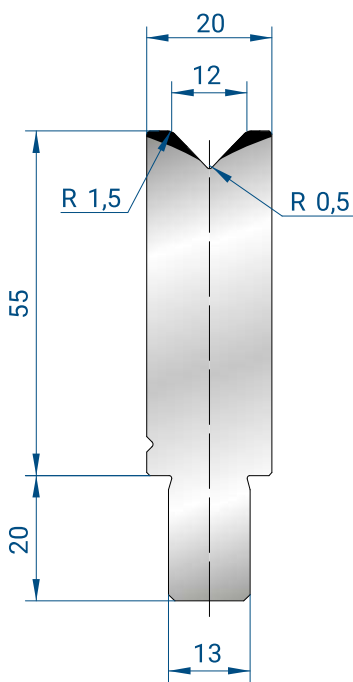

### 3107

Mat = C45  
Max T/m = 100  
 $\alpha = 88^\circ$

1000 mm	10,3 kg
500 mm	5,2 kg
1100 mm FRAZ. / SECT.	11,4 kg
550 mm SECT. SHORT	5,7 kg
100 mm	1,0 kg

### 3108

Mat = C45  
Max T/m = 100  
 $\alpha = 88^\circ$

1000 mm	14,4 kg
500 mm	7,2 kg
1100 mm FRAZ. / SECT.	15,8 kg
550 mm SECT. SHORT	7,9 kg
100 mm	1,4 kg

### 3109

Mat = C45  
Max T/m = 100  
 $\alpha = 88^\circ$

1000 mm	14,1 kg
500 mm	7,1 kg
1100 mm FRAZ. / SECT.	15,5 kg
550 mm SECT. SHORT	7,7 kg
100 mm	2,8 kg

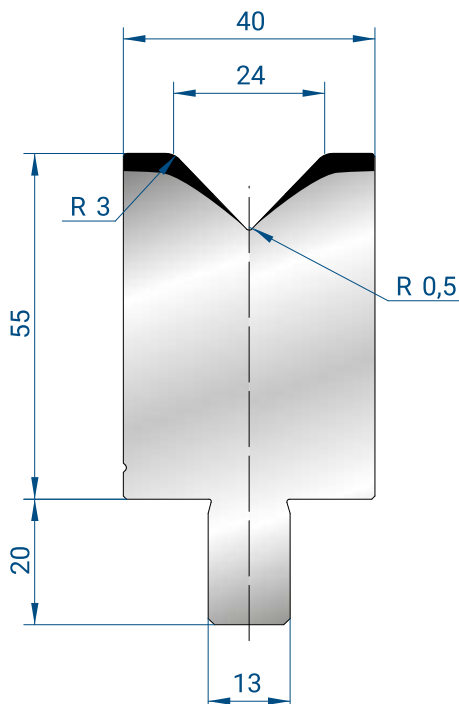

### 3110

Mat = C45  
Max T/m = 100  
 $\alpha = 88^\circ$

1000 mm	18,1 kg
500 mm	9,0 kg
1100 mm FRAZ. / SECT.	19,9 kg
550 mm SECT. SHORT	10,0 kg
100 mm	1,8 kg

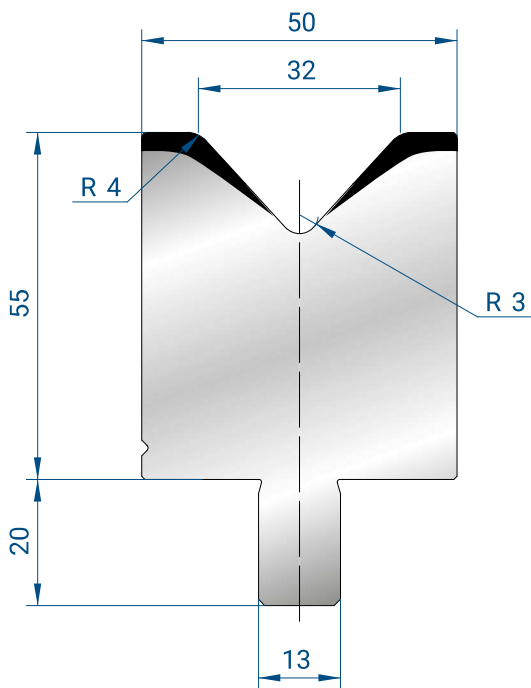

### 3111

Mat = C45  
 Max T/m = 100  
 $\alpha = 85^\circ$

1000 mm	21,4 kg
500 mm	10,7 kg
1100 mm FRAZ. / SECT.	23,5 kg
550 mm SECT. SHORT	11,8 kg
100 mm	2,1 kg

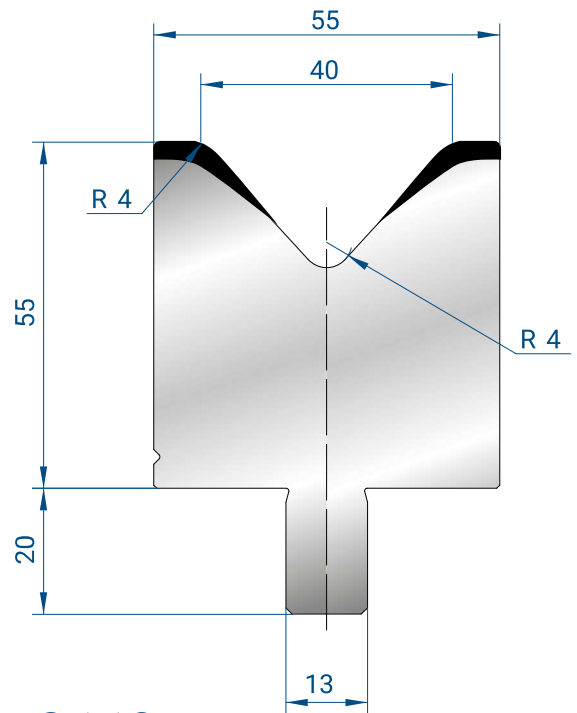

### 3112

Mat = C45  
 Max T/m = 100  
 $\alpha = 85^\circ$

1000 mm	22,3 kg
500 mm	11,2 kg
1100 mm FRAZ. / SECT.	24,5 kg
550 mm SECT. SHORT	12,3 kg
100 mm	2,2 kg

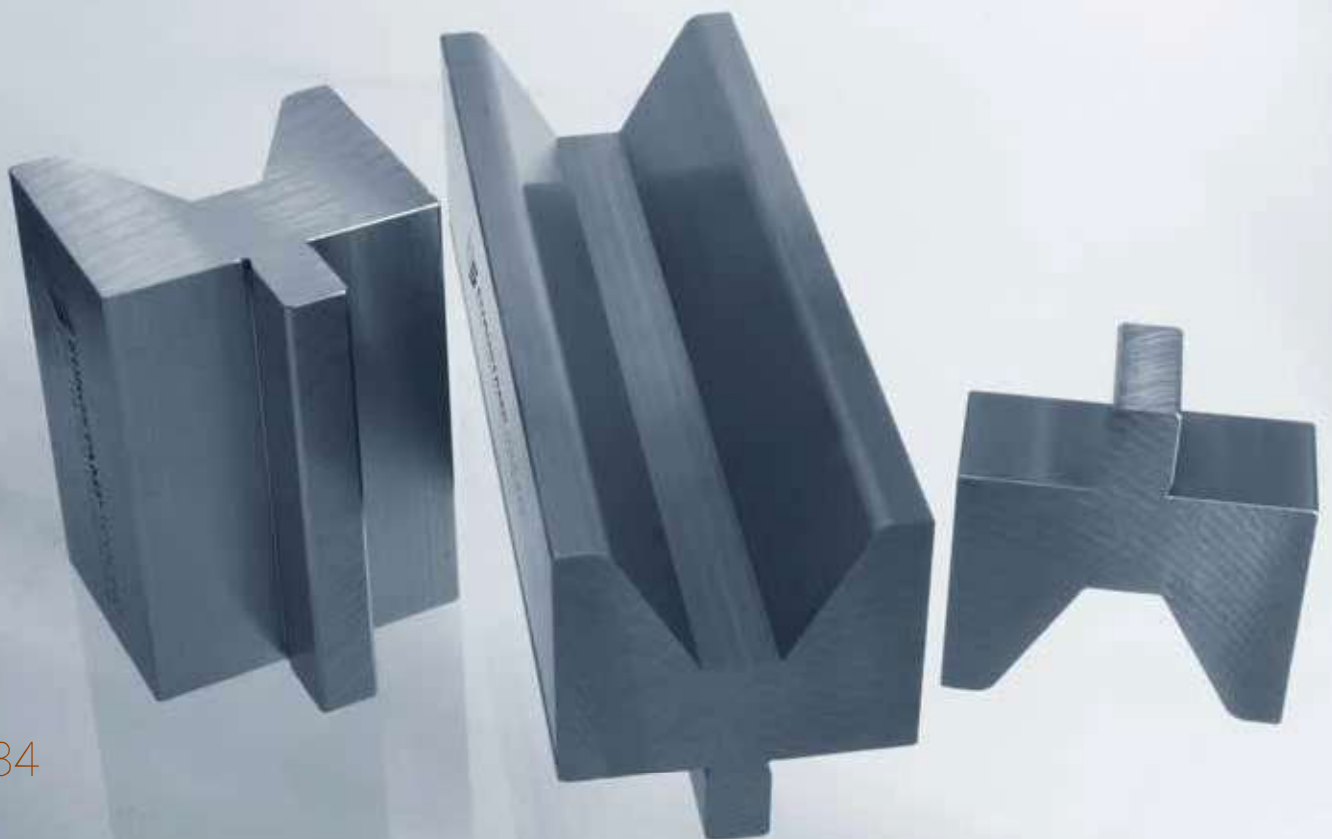

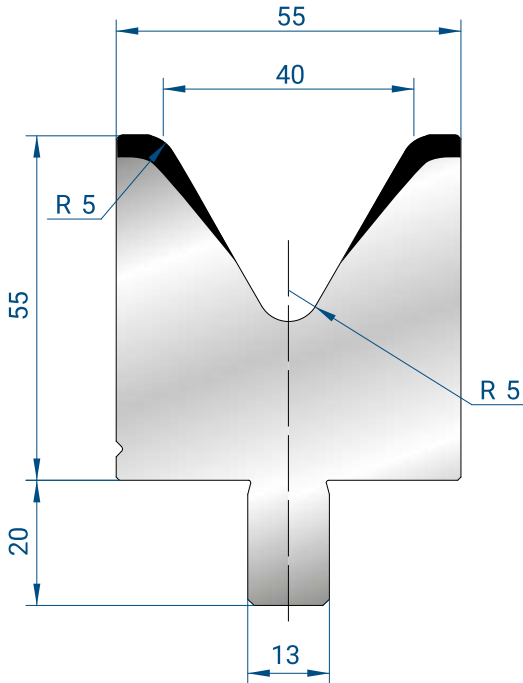

### 3113

Mat = C45  
 Max T/m = 100  
 $\alpha = 60^\circ$

1000 mm	20,4 kg
500 mm	10,2 kg
1100 mm FRAZ. / SECT.	22,4 kg
550 mm SECT. SHORT	11,2 kg
100 mm	2,0 kg

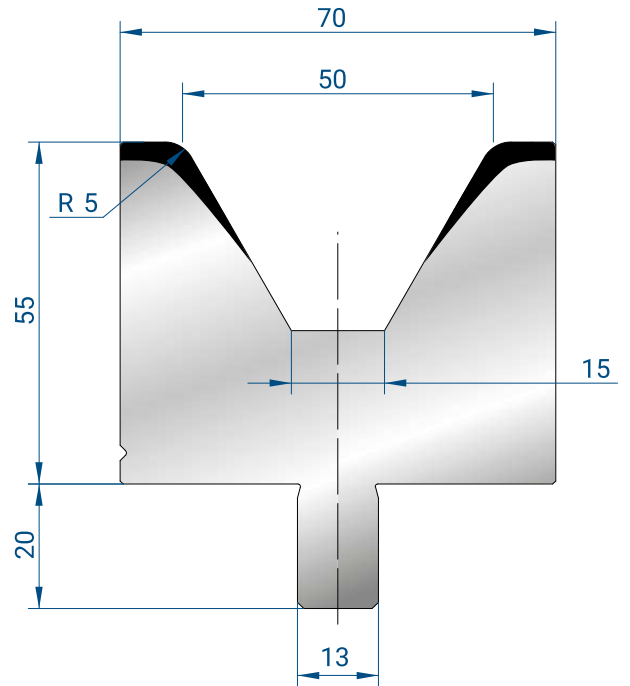

### 3179

Mat = C45  
 Max T/m = 100  
 $\alpha = 60^\circ$

1000 mm	24,4 kg
500 mm	12,2 kg
1100 mm FRAZ. / SECT.	26,9 kg
550 mm SECT. SHORT	13,5 kg
100 mm	2,4 kg

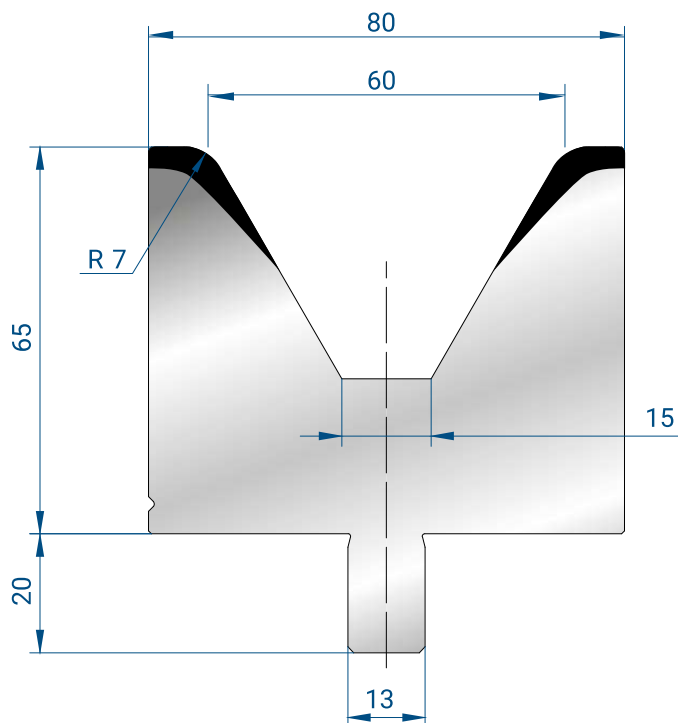

### 3114

Mat = C45  
 Max T/m = 100  
 $\alpha = 60^\circ$

1000 mm	31,2 kg
500 mm	15,6 kg
1100 mm FRAZ. / SECT.	34,4 kg
550 mm SECT. SHORT	17,2 kg
100 mm	3,1 kg

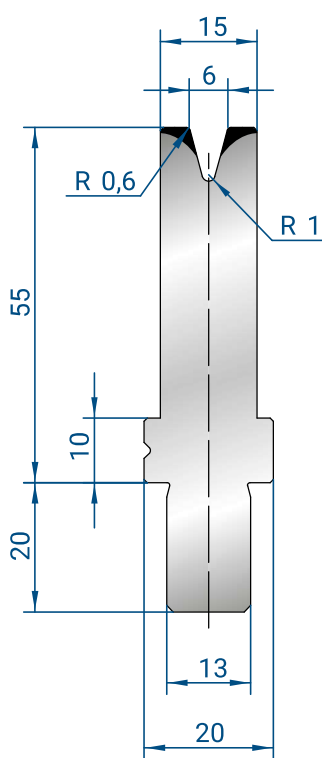

### 3115

Mat = C45  
 Max T/m = 35  
 $\alpha = 30^\circ$

1000 mm	8,6 kg
500 mm	4,3 kg
1100 mm FRAZ. / SECT.	9,5 kg
550 mm SECT. SHORT	4,7 kg
100 mm	0,9 kg

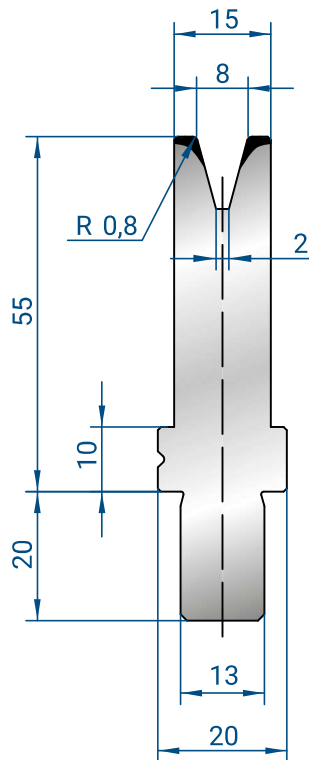

### 3116

Mat = C45  
 Max T/m = 40  
 $\alpha = 30^\circ$

1000 mm	8,4 kg
500 mm	4,2 kg
1100 mm FRAZ. / SECT.	9,3 kg
550 mm SECT. SHORT	4,6 kg
100 mm	0,8 kg

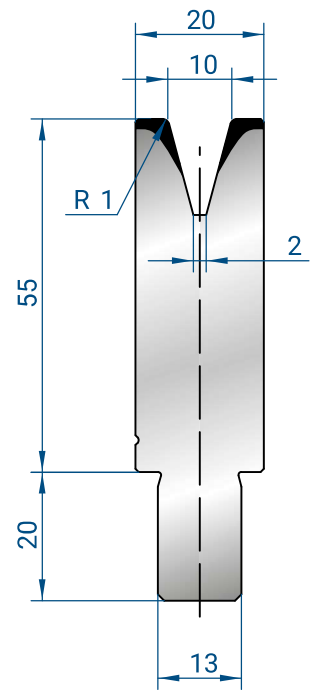

### 3117

Mat = C45  
 Max T/m = 50  
 $\alpha = 30^\circ$

1000 mm	9,9 kg
500 mm	5,0 kg
1100 mm FRAZ. / SECT.	10,9 kg
550 mm SECT. SHORT	5,5 kg
100 mm	1,0 kg

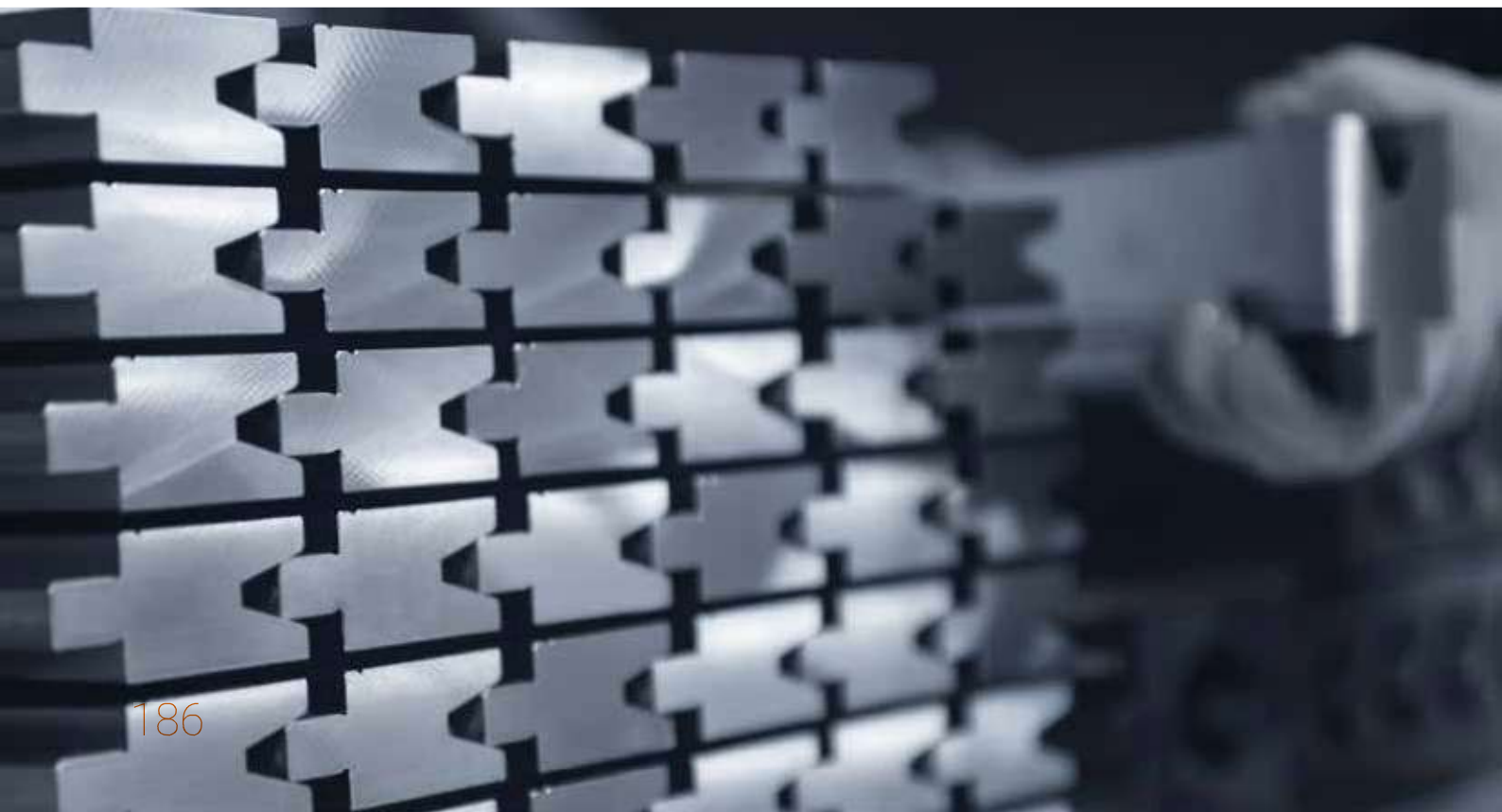

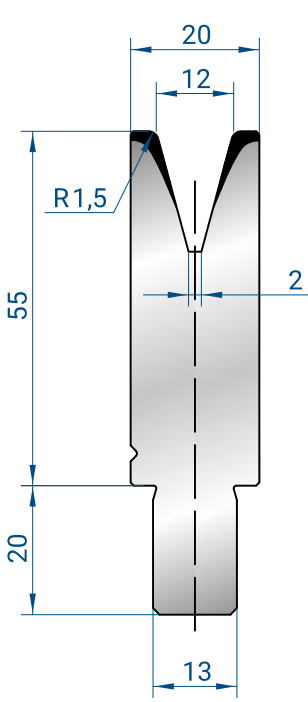

### 3118

Mat = C45  
Max T/m = 40  
 $\alpha = 30^\circ$

1000 mm	9,6 kg
500 mm	4,8 kg
1100 mm FRAZ. / SECT.	10,6 kg
550 mm SECT. SHORT	5,3 kg
100 mm	1,0 kg

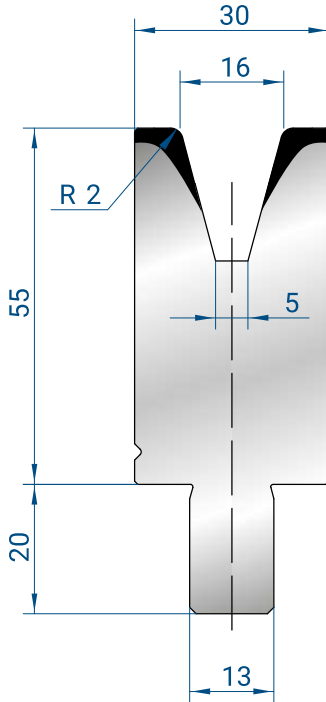

### 3119

Mat = C45  
Max T/m = 50  
 $\alpha = 30^\circ$

1000 mm	13,2 kg
500 mm	6,6 kg
1100 mm FRAZ. / SECT.	14,6 kg
550 mm SECT. SHORT	7,3 kg
100 mm	1,3 kg

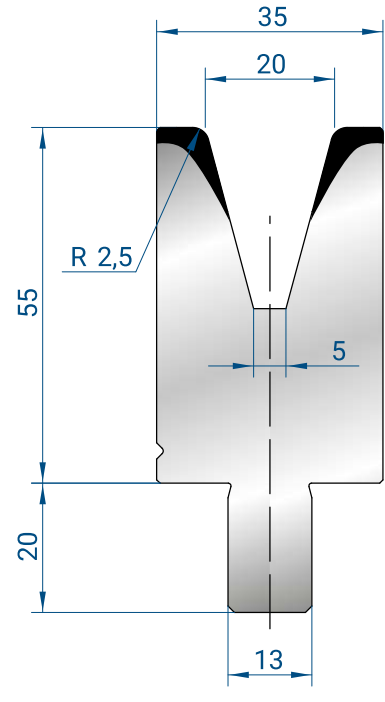

### 3120

Mat = C45  
Max T/m = 55  
 $\alpha = 30^\circ$

1000 mm	14,3 kg
500 mm	7,2 kg
1100 mm FRAZ. / SECT.	15,8 kg
550 mm SECT. SHORT	7,9 kg
100 mm	1,4 kg

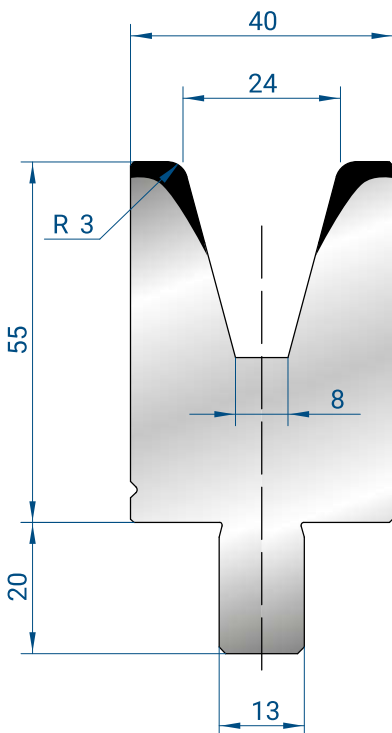

### 3121

Mat = C45  
Max T/m = 65  
 $\alpha = 30^\circ$

1000 mm	15,5 kg
500 mm	7,7 kg
1100 mm FRAZ. / SECT.	17,0 kg
550 mm SECT. SHORT	8,5 kg
100 mm	1,5 kg

### 3122

Mat = C45  
Max T/m = 65  
 $\alpha = 30^\circ$

1000 mm	23,4 kg
500 mm	11,7 kg
1100 mm FRAZ. / SECT.	25,8 kg
550 mm SECT. SHORT	12,9 kg
100 mm	2,3 kg

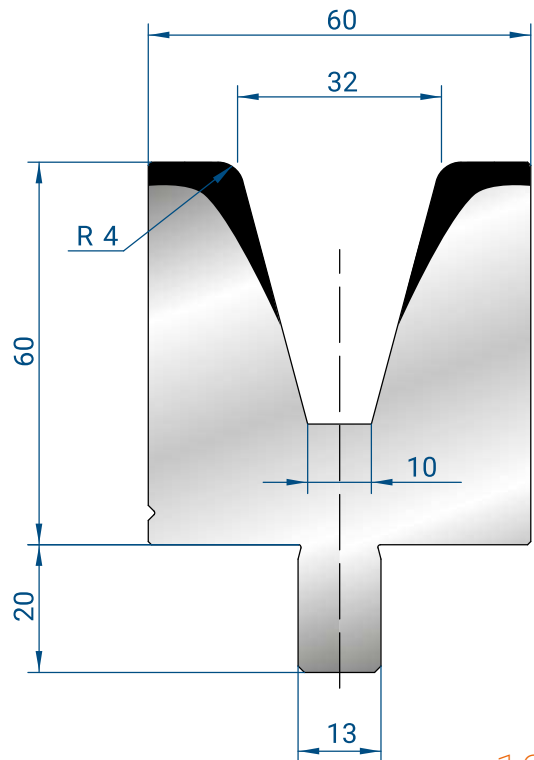

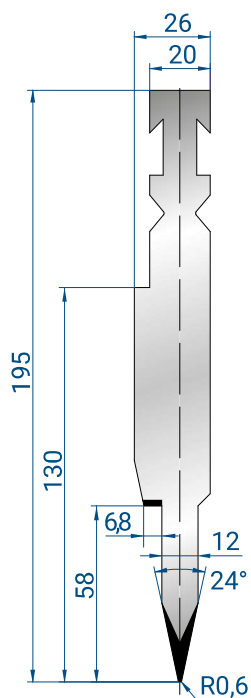

### 1254

**Mat** = C45  
bonificato / *tempered*  
**Max T/m** = 80

500 mm	13,7 kg
550 mm FRAZ. / SECT.	13,9 kg
100 mm	2,7 kg

#### Spessore / Thickness

Max 1,5 mm  
Ferro / *Mild steel*

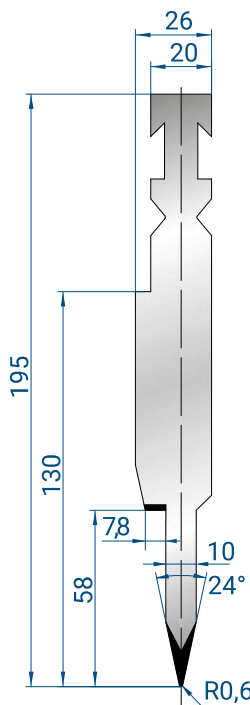

### 1253

**Mat** = C45  
bonificato / *tempered*  
**Max T/m** = 80

500 mm	13,4 kg
550 mm FRAZ. / SECT.	13,7 kg
100 mm	2,7 kg

#### Spessore / Thickness

Max 1,5 mm  
Ferro / *Mild steel*

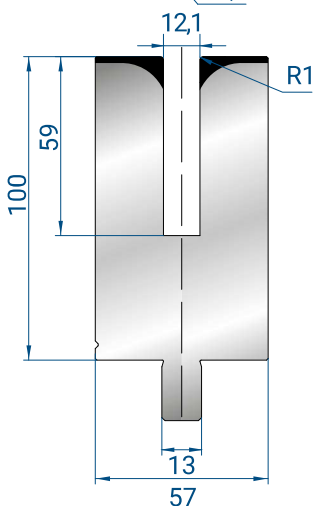

### 3175

**Mat** = C45  
bonificato / *tempered*  
**Max T/m** = 50

500 mm	20,5 kg
550 mm FRAZ. / SECT.	22,6 kg
100 mm	4,1 kg

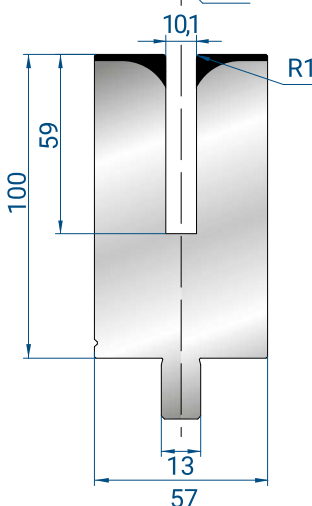

### 3174

**Mat** = C45  
bonificato / *tempered*  
**Max T/m** = 50

500 mm	21,0 kg
550 mm FRAZ. / SECT.	23,1 kg
100 mm	4,2 kg



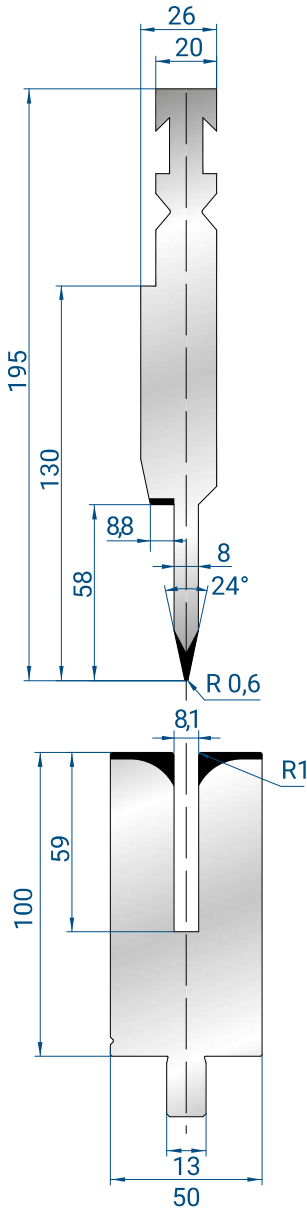

## 1252

**Mat** = C45  
 bonificato / tempered  
**Max T/m** = 80

500 mm	13,0 kg
550 mm	13,3 kg
FRAZ. / SECT.	
100 mm	2,6 kg

### Spessore / Thickness

Max 1,2 mm  
 Ferro / Mild steel

## 3157

**Mat** = C45  
 bonificato / tempered  
**Max T/m** = 50

500 mm	18,7 kg
550 mm	20,6 kg
FRAZ. / SECT.	
100 mm	3,7 kg

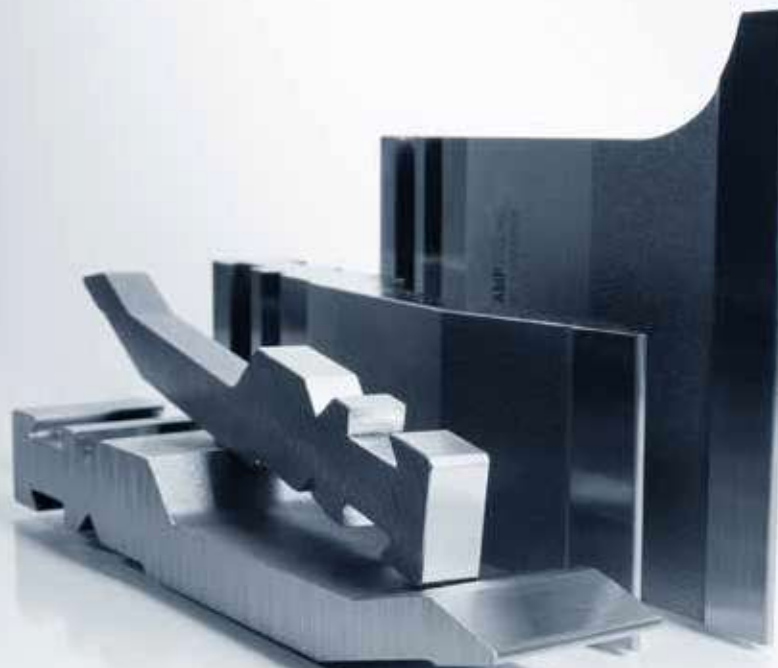
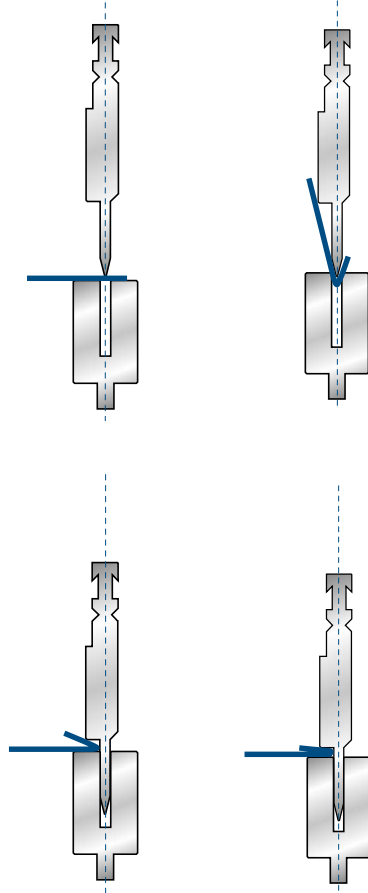



# ACCESSORI ACCESSORIES





SUPPORTI PER INSERTI RAGGIATI  
RADIUS INSERTS HOLDERS

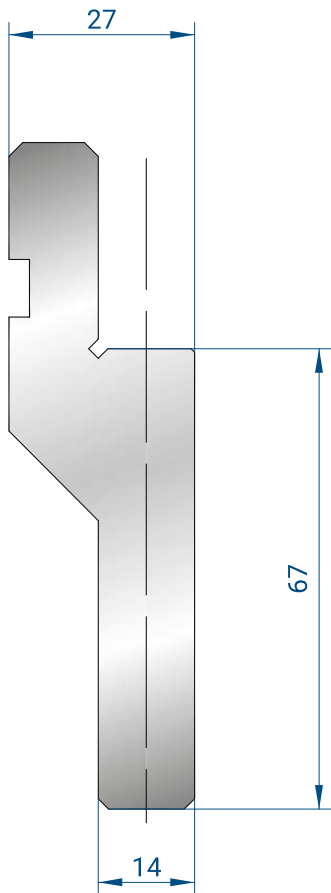

**1036**

AMADA PROMECAM STYLE

Mat = C45

Max T/m = 80

830 mm	9,2 kg
410 mm	4,5 kg

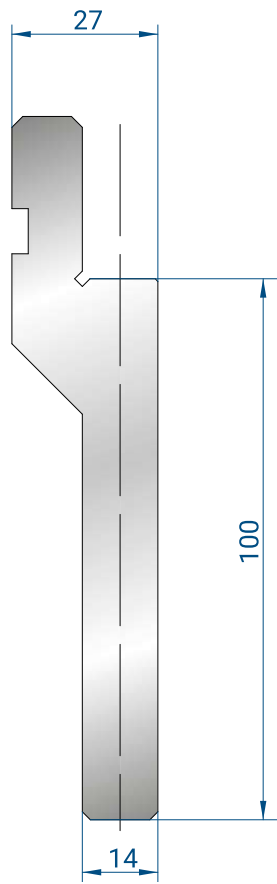

**1096**

AMADA PROMECAM STYLE

Mat = C45

Max T/m = 80

830 mm	12,2 kg
410 mm	6,0 kg

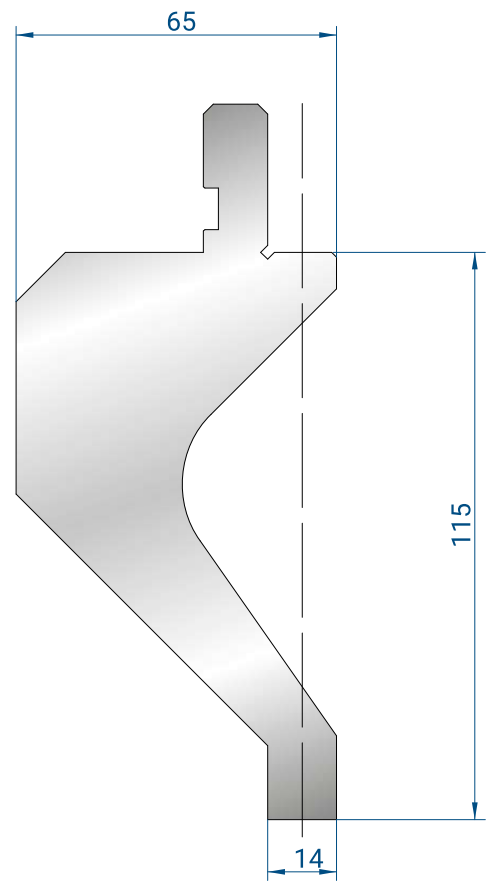

**1090**

AMADA PROMECAM STYLE

Mat = C45

Max T/m = 50

830 mm	25,6 kg
410 mm	12,6 kg



# SUPPORTI PER INSERTI RAGGIATI RADIUS INSERTS HOLDERS

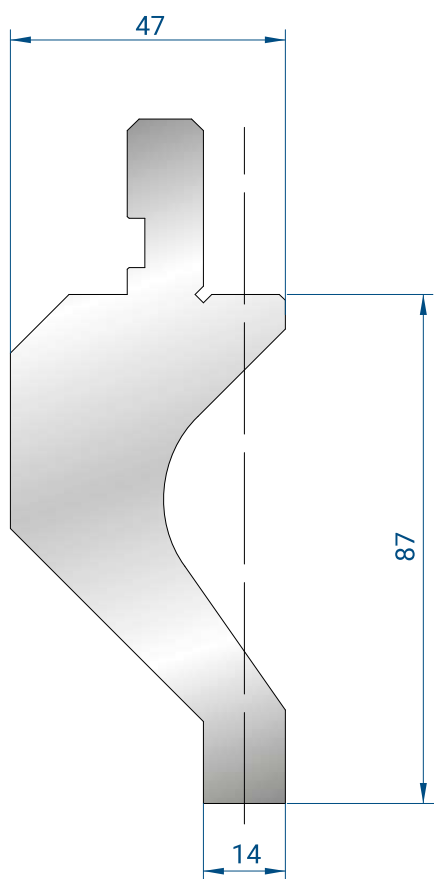

## 1091

**AMADA PROMECAM STYLE**

**Mat = C45**

**Max T/m = 50**

830 mm	15,8 kg
410 mm	7,8 kg

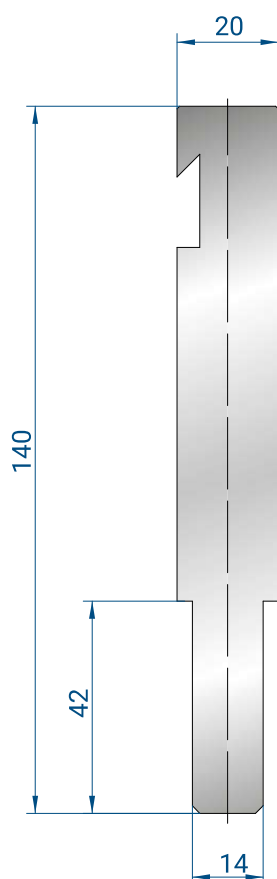

## 1239

**BYSTRONIC R STYLE**

**Mat = C45**

**Max T/m = 80**

830 mm	15,3 kg
410 mm	7,6 kg

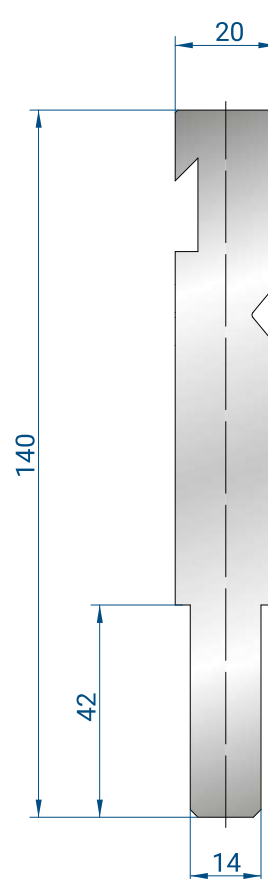

## 1273

**BYSTRONIC RF - A STYLE**

**Mat = C45**

**Max T/m = 80**

830 mm	15,1 kg
412 mm	7,5 kg



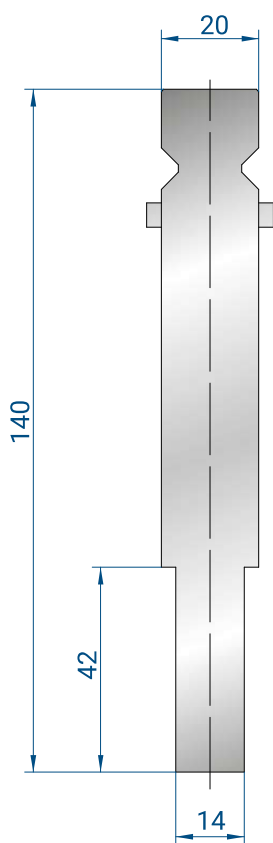

## 1240

TRUMPF / WILA STYLE

Mat = C45

Max T/m = 80

830 mm	15,6 kg
410 mm	7,7 kg

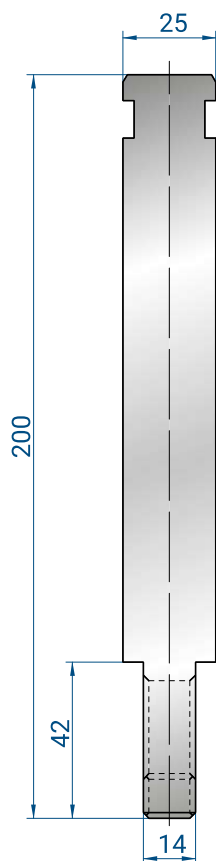

## 1305

WEINBRENNER STYLE

Mat = C45

Max T/m = 80

830 mm	28,3 kg
410 mm	14,0 kg

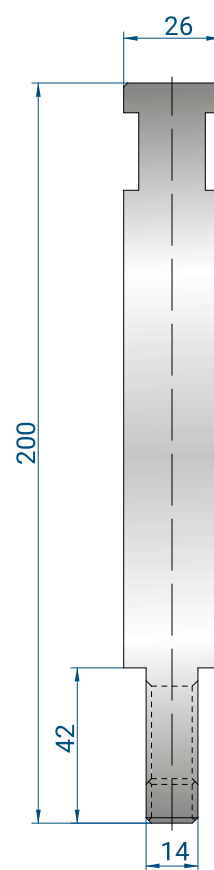

## 1306

EHT STYLE

Mat = C45

Max T/m = 80

830 mm	28,6 kg
410 mm	14,1 kg

SUPPORTI PER INSERTI RAGGIATI PICCOLI  
SMALL RADIUS INSERTS HOLDERS

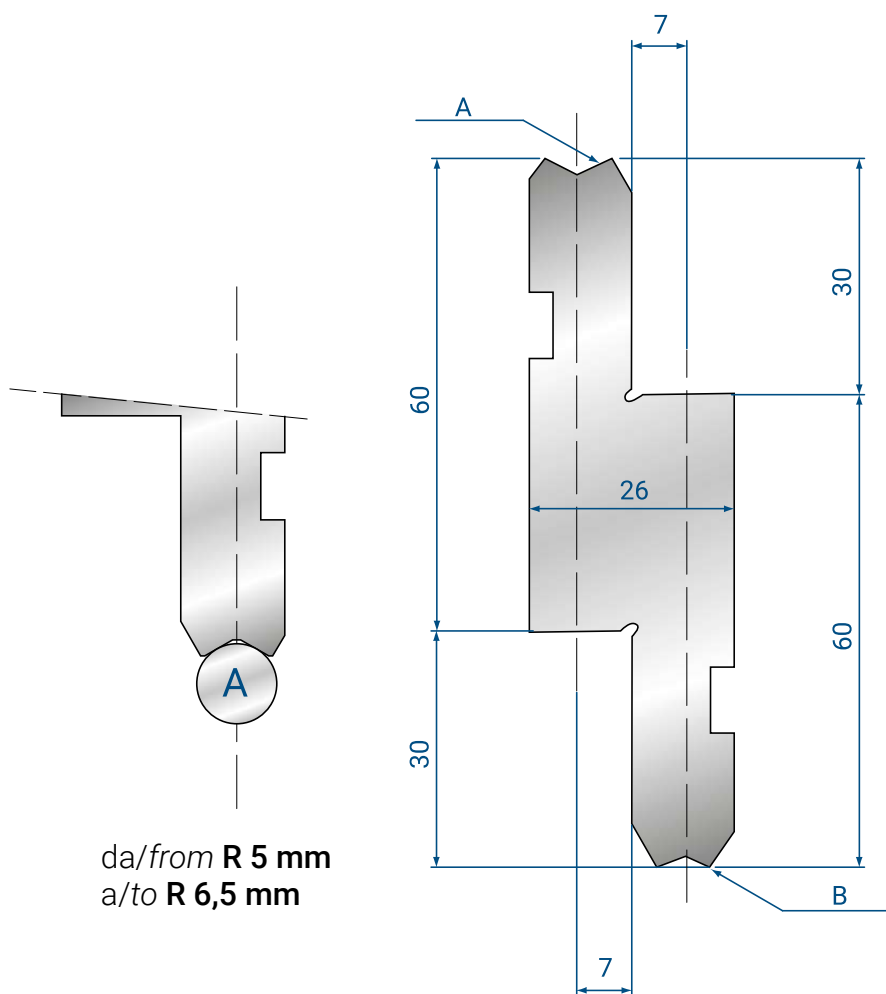

da/from R 5 mm  
a/to R 6,5 mm

## 1155

AMADA/PROMECAM STYLE  
Mat = C45

830 mm	9,4 kg
410 mm	4,6 kg

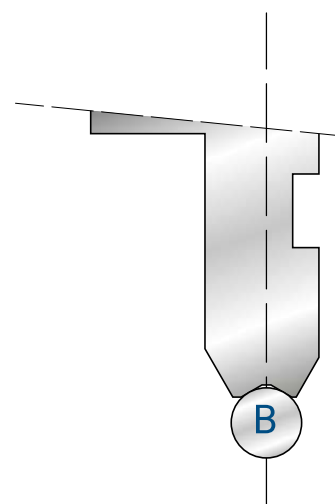

da/from R 3 mm  
a/to R 4,5 mm

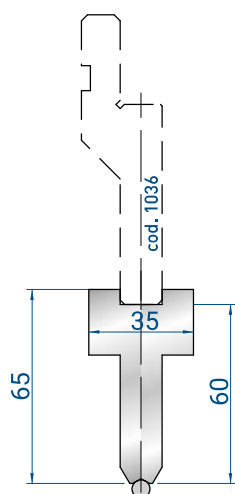

## 1296

da/from R 3 mm  
a/to R 4,5 mm

830 mm	8,2 kg
410 mm	4,1 kg

## 4275

PEZZO DI RICAMBIO  
SPARE PART

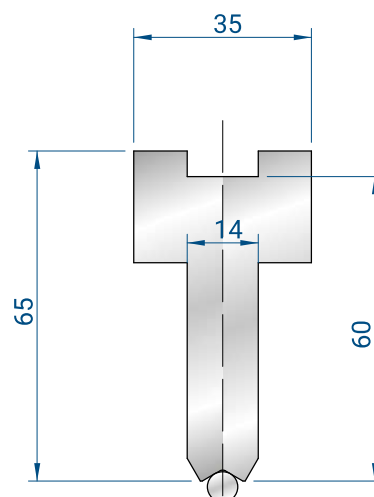
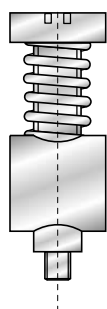

## 1297

da/from R 5 mm  
a/to R 6,5 mm

830 mm	8,2 kg
410 mm	4,1 kg

# INSERTI RAGGIATI PICCOLI SMALL RADIUS INSERTS

SOLO PER SUPPORTI  
ONLY FOR HOLDERS

1155 - 1296 - 1297

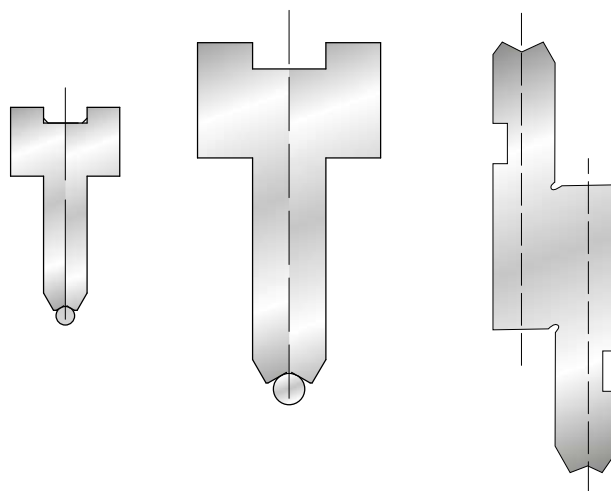

## 1180

Mat = C45

835 mm	0,2 kg
415 mm	0,1 kg

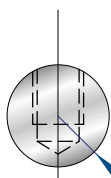

R 3

## 1181

Mat = C45

835 mm	0,3 kg
415 mm	0,1 kg

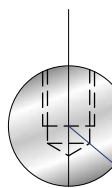

R 3,5

## 1182

Mat = C45

835 mm	0,3 kg
415 mm	0,2 kg

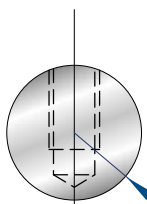

R 4

## 1183

Mat = C45

835 mm	0,4 kg
415 mm	0,2 kg

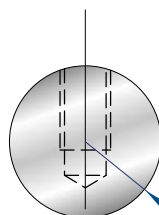

R 4,5

## 1184

Mat = C45

835 mm	0,5 kg
415 mm	0,3 kg

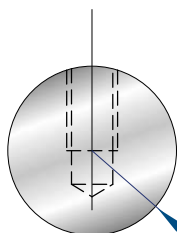

R 5

## 1185

Mat = C45

835 mm	0,6 kg
415 mm	0,3 kg

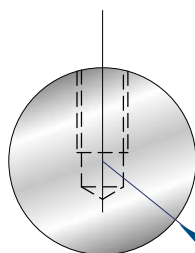

R 5,5

## 1186

Mat = C45

835 mm	0,7 kg
415 mm	0,4 kg

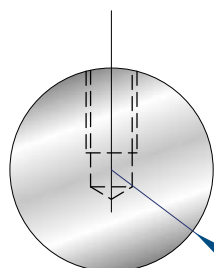

R 6

## 1187

Mat = C45

835 mm	0,9 kg
415 mm	0,4 kg

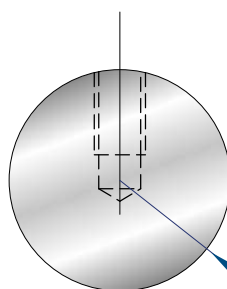

R 6,5

GAMMA SUPPORTI DISPONIBILI A PAG.  
AVAILABLE RANGE OF HOLDERS ON PAG.

**192; 193; 194**

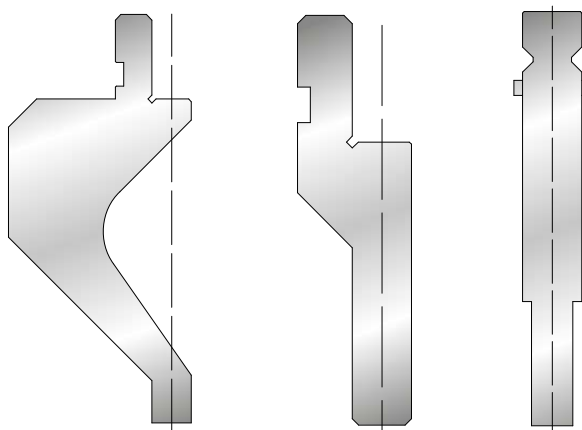

## 1100

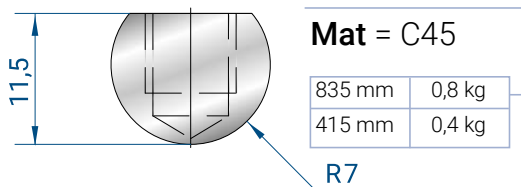

## 1101

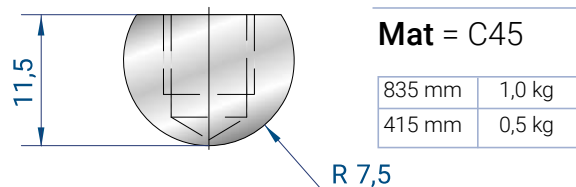

## 1102

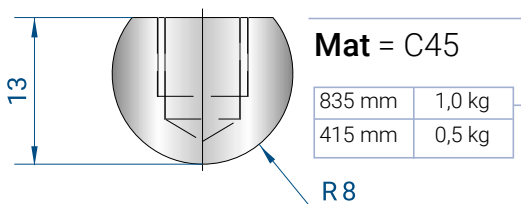

## 1103

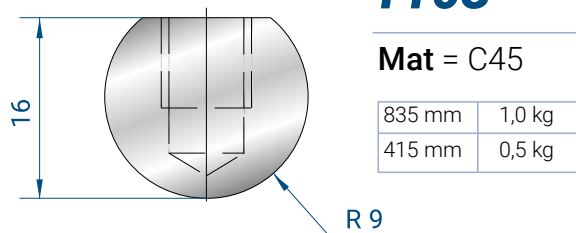

## 1037

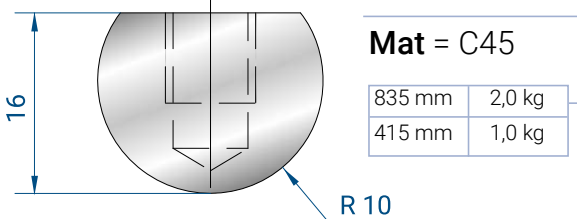

## 1104

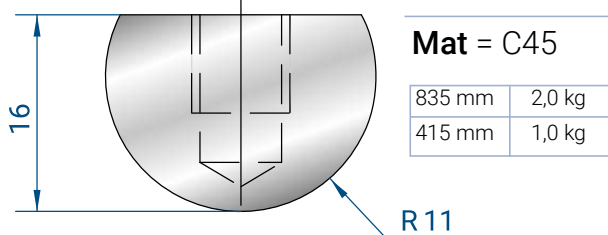

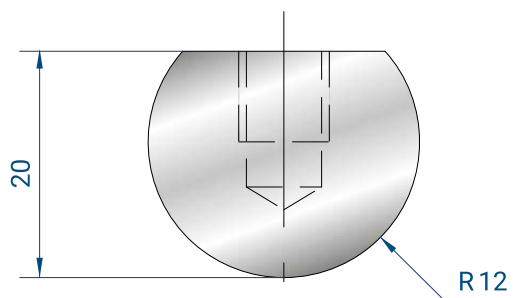

**1106**

Mat = C45

835 mm	2,0 kg
415 mm	1,0 kg

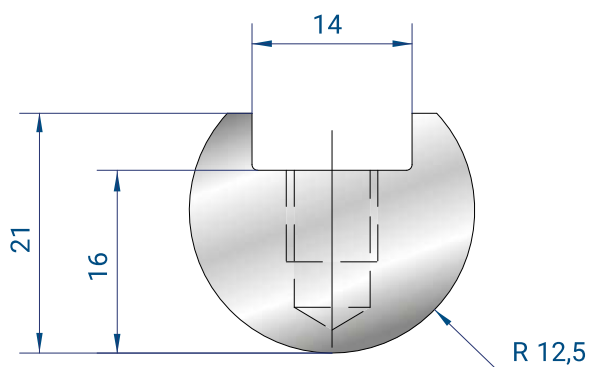

**1107**

Mat = C45

835 mm	3,0 kg
415 mm	1,5 kg

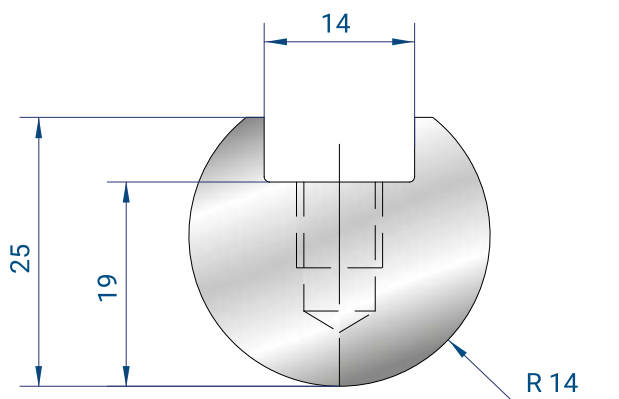

**1109**

Mat = C45

835 mm	4,0 kg
415 mm	2,0 kg

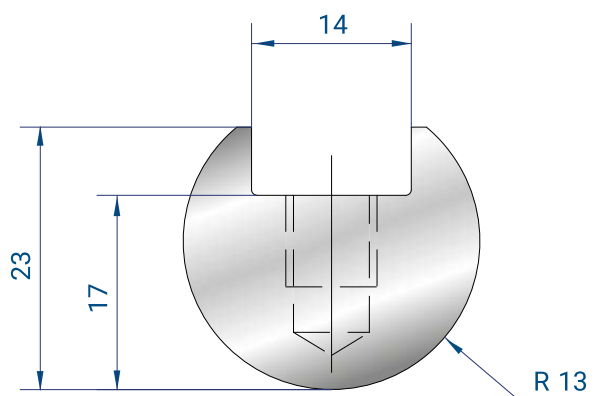

**1108**

Mat = C45

835 mm	3,0 kg
415 mm	1,0 kg

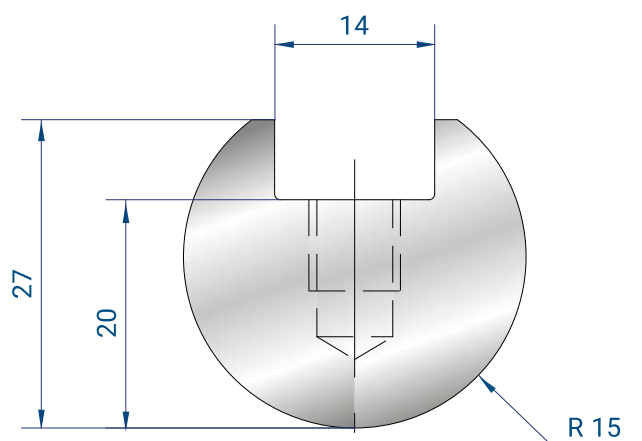

**1038**

Mat = C45

835 mm	4,0 kg
415 mm	2,0 kg

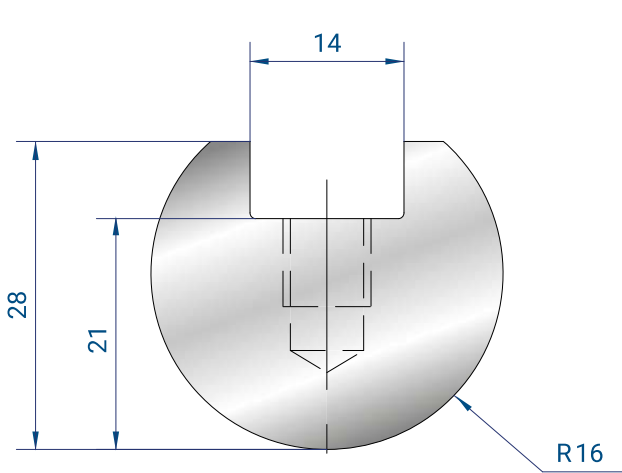

**1110**

Mat = C45

835 mm	5,0 kg
415 mm	2,0 kg

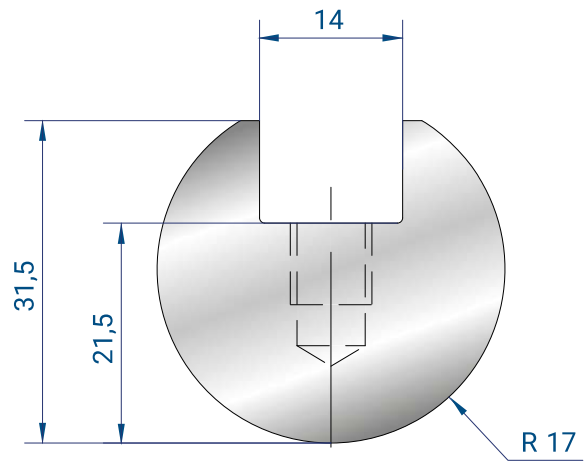

**1111**

Mat = C45

835 mm	5,0 kg
415 mm	2,5 kg

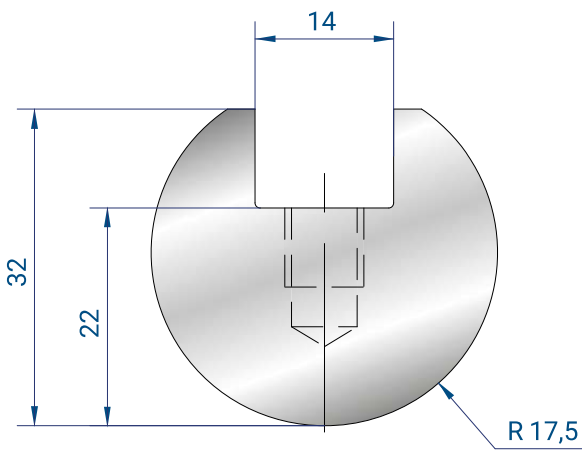

**1039**

Mat = C45

835 mm	5,0 kg
415 mm	2,5 kg

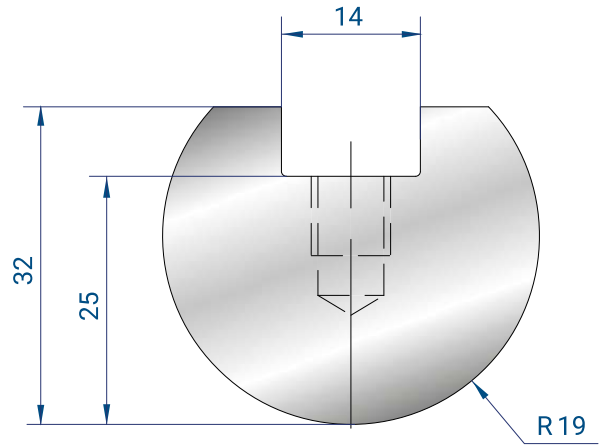

**1112**

Mat = C45

835 mm	6,0 kg
415 mm	3,0 kg

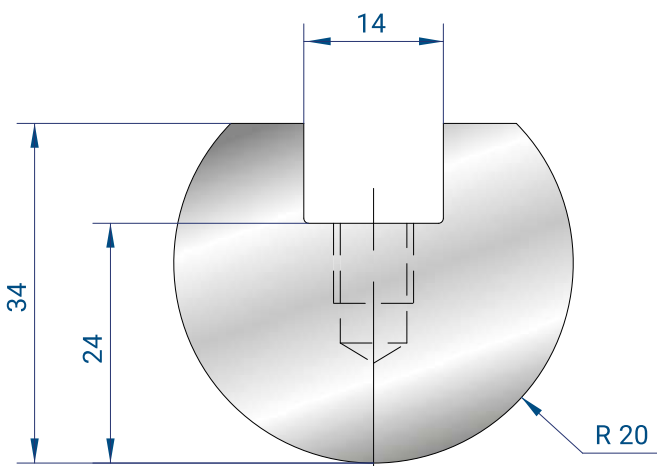

**1040**

Mat = C45

835 mm	6,0 kg
415 mm	3,0 kg

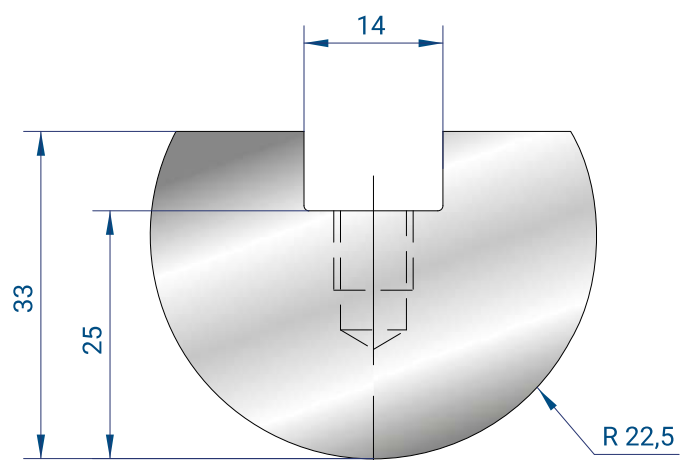

**1113**

Mat = C45

835 mm	8,0 kg
415 mm	4,0 kg

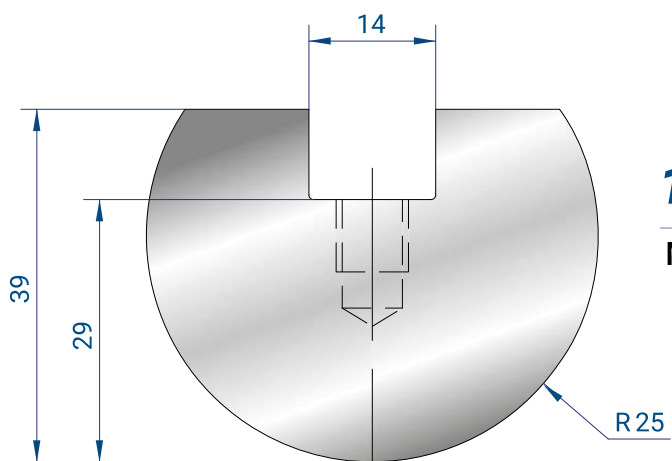

**1041**

Mat = C45

835 mm	9,0 kg
415 mm	4,0 kg

**1114**  
Mat = C45

835 mm	12,0 kg
415 mm	6,0 kg

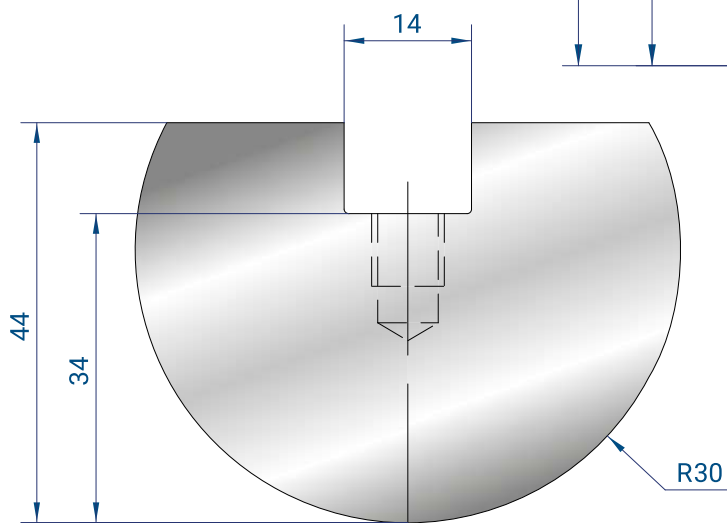
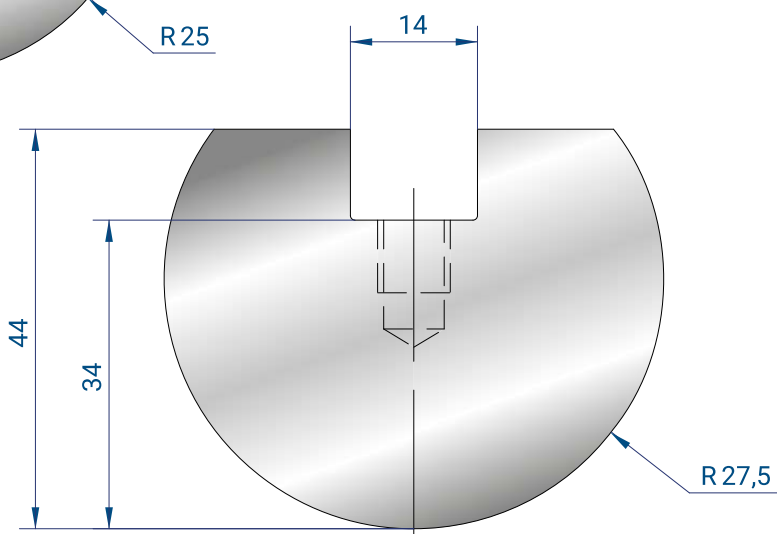

**1042**

Mat = C45

835 mm	13,0 kg
415 mm	6,0 kg

**1115**  
Mat = C45

835 mm	21,0 kg
415 mm	10,0 kg

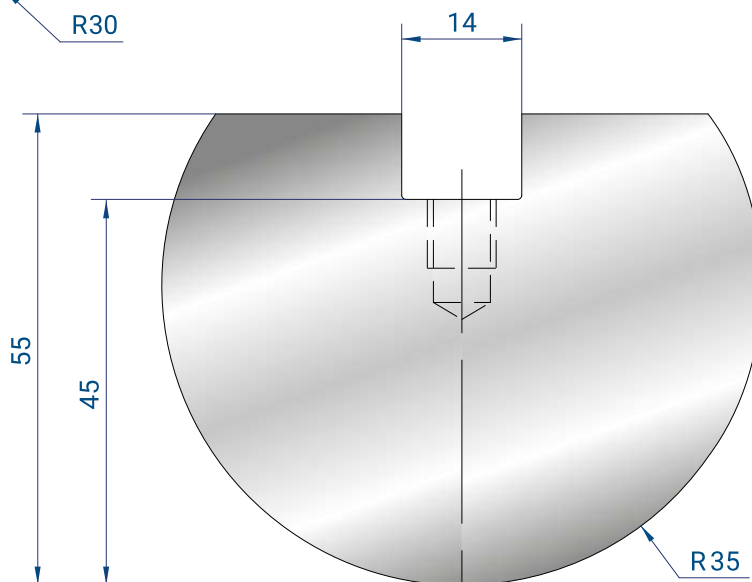

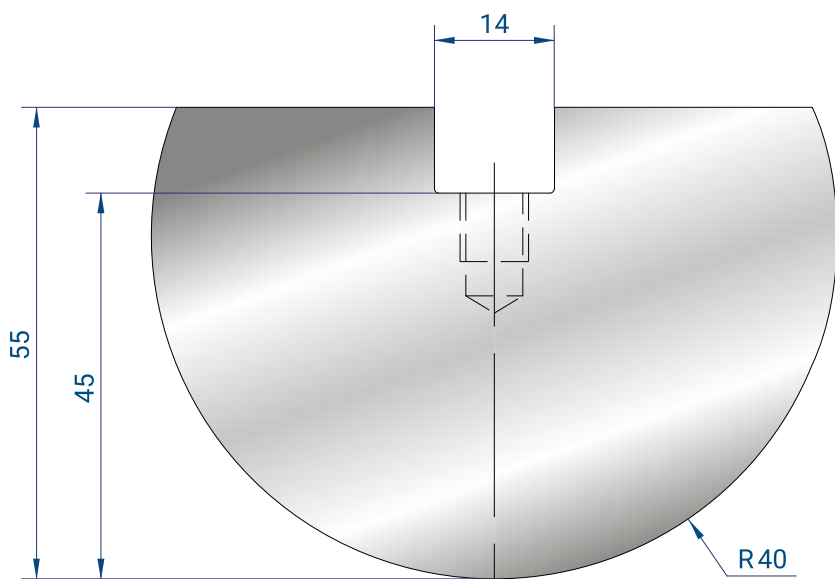

**1116**

Mat = C45

835 mm	24,0 kg
415 mm	12,0 kg

**1117**  
Mat = C45

835 mm	29,0 kg
415 mm	14,0 kg

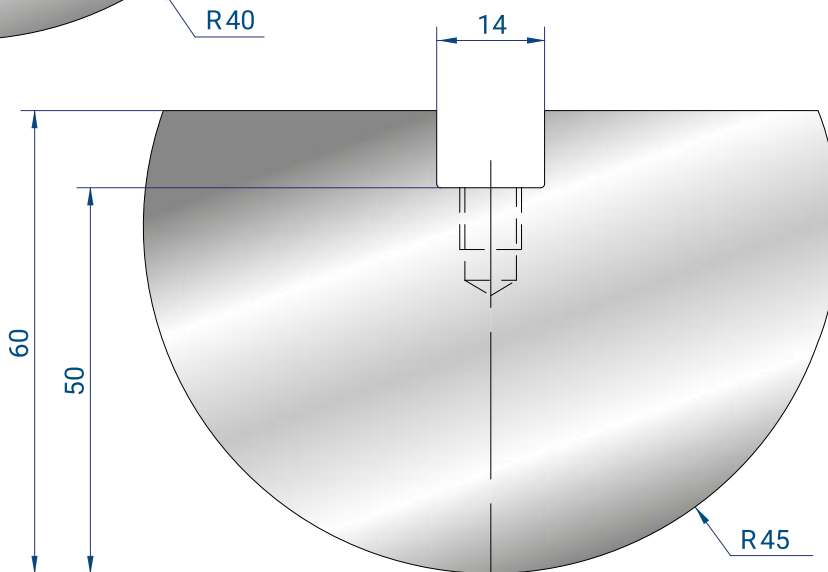

**1118**

Mat = C45

835 mm	34,0 kg
415 mm	17,0 kg

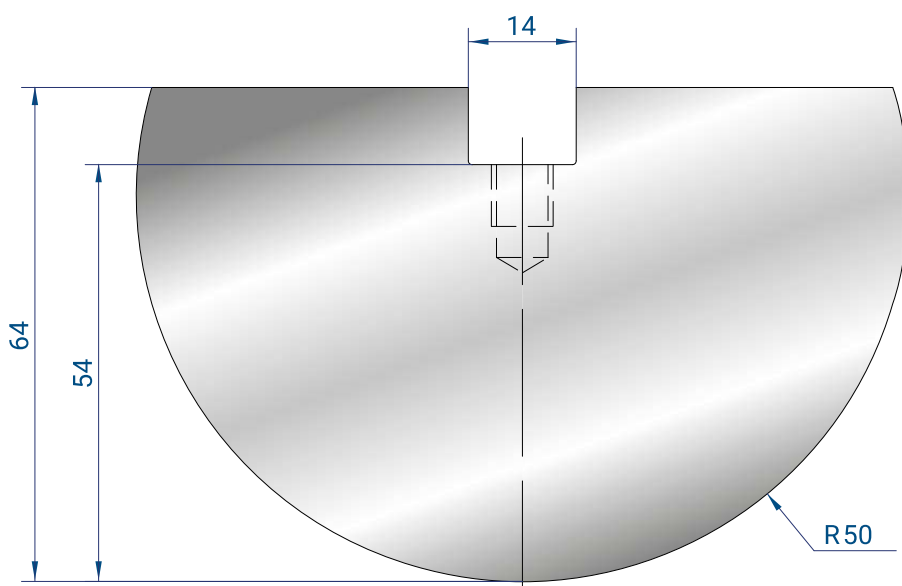

INSERTI QUADRI E ACCESSORI  
FLATTENING INSERTS AND ACCESSORIES

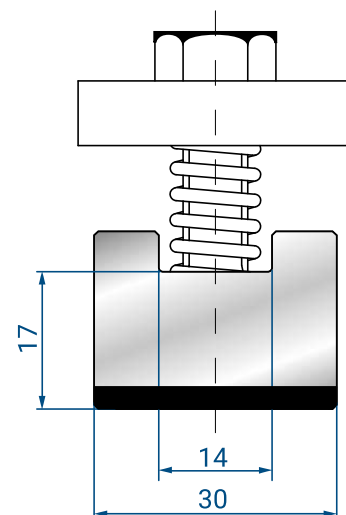

**1043**

Mat = C45

835 mm	3,8 kg
415 mm	1,9 kg

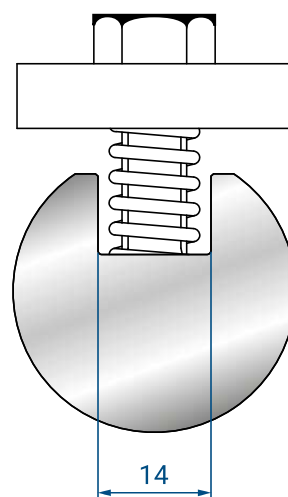

**4274**

Mat = C45

MOLLA + VITE + PIASTRINA  
SPRING + SCREW + PLATE

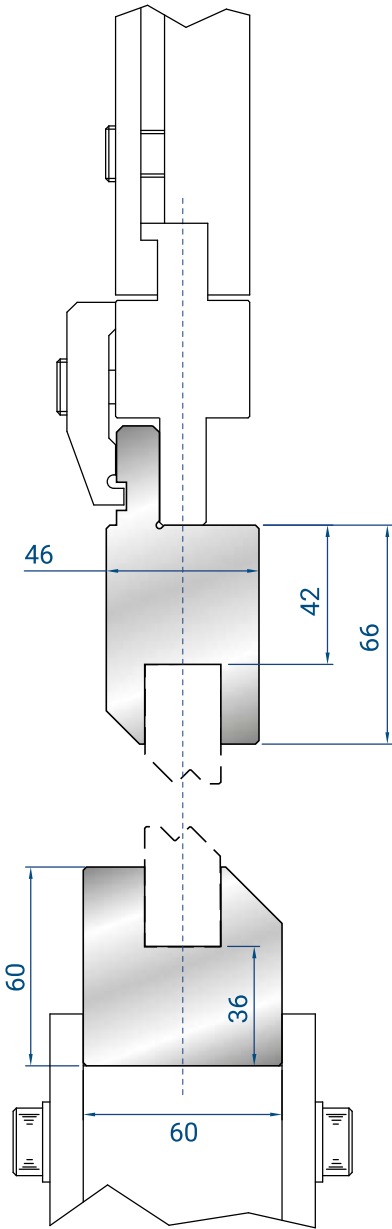

**1150**

AMADA /  
PROMECAM  
STYLE

Mat = C45

835 mm	37,1 kg
415 mm	18,4 kg

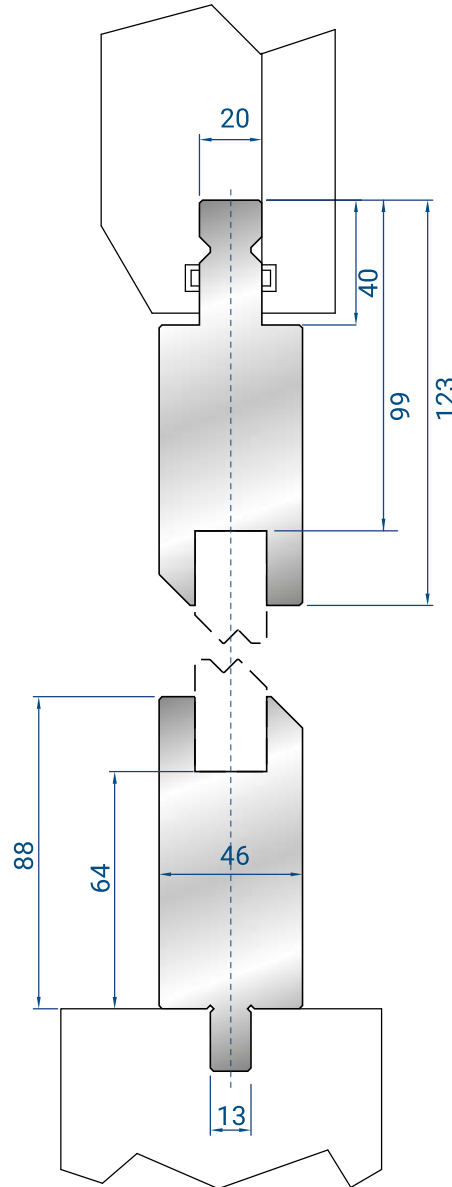

**1242**

TRUMPF /WILA  
STYLE

Mat = C45

835 mm	50,0 kg
415 mm	24,9 kg

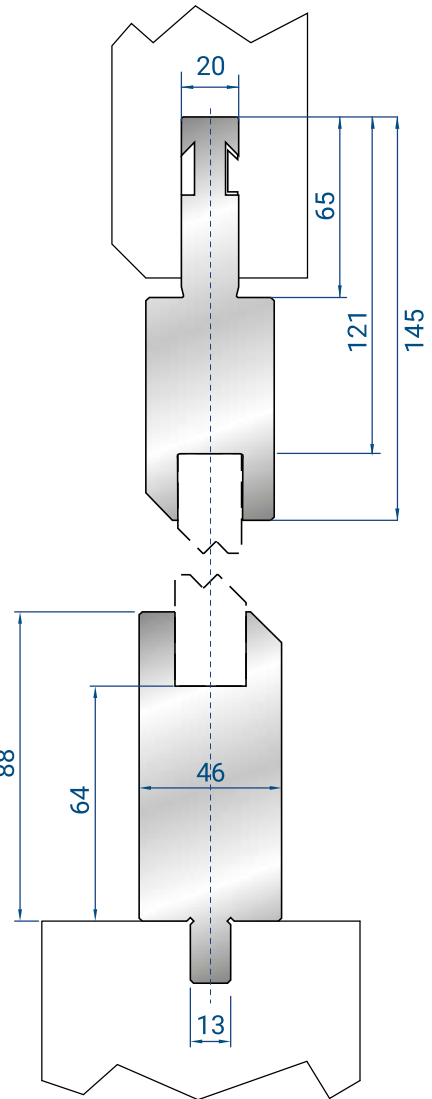

**1198**

BYSTRONIC  
STYLE

Mat = C45

835 mm	51,7 kg
415 mm	25,7 kg

ATTACCO / UPPER TANG RF-A

INCLUSO SU RICHIESTA  
AVAILABLE ON DEMAND  
AT NO COST

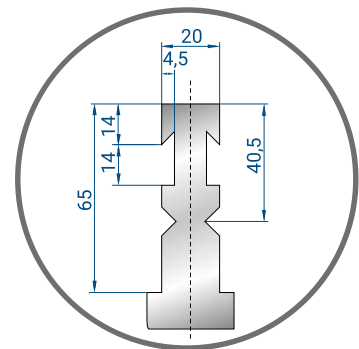

## TABELLA INSERTI A Z / OFFSET TOOL HOLDERS

CODE	Z	GRADI DEGREES	SPESSORE MAX. LAMIERA MAX SHEET THICKNESS
<b>1130</b>	1	160°	0,5 mm
<b>1276</b>	1	90°	0,5 mm
<b>1131</b>	1,5	160°	0,6 mm
<b>1277</b>	1,5	90°	0,6 mm
<b>1132</b>	2	150°	0,8 mm
<b>1274</b>	2	90°	0,8 mm
<b>1133</b>	2,5	140°	1,0 mm
<b>1275</b>	2,5	90°	1,0 mm
<b>1134</b>	3	90°	1,0 mm
<b>1135</b>	3,5	90°	1,2 mm
<b>1136</b>	4	90°	1,2 mm
<b>1137</b>	4,5	90°	1,5 mm
<b>1138</b>	5	90°	1,5 mm
<b>1139</b>	5,5	90°	1,5 mm
<b>1140</b>	6	90°	1,5 mm
<b>1141</b>	6,5	90°	1,5 mm
<b>1142</b>	7	90°	2,0 mm
<b>1143</b>	7,5	90°	2,0 mm
<b>1144</b>	8	90°	2,5 mm
<b>1145</b>	9	90°	2,5 mm
<b>1146</b>	10	90°	3,0 mm
<b>1147</b>	11	90°	3,0 mm
<b>1148</b>	12	90°	3,0 mm
<b>1278</b>	13	90°	3,0 mm
<b>1279</b>	14	90°	3,0 mm
<b>1280</b>	15	90°	3,0 mm



INSERTI A Z - 140° - 150° - 160°  
 OFFSET TOOL - 140° - 150° - 160°

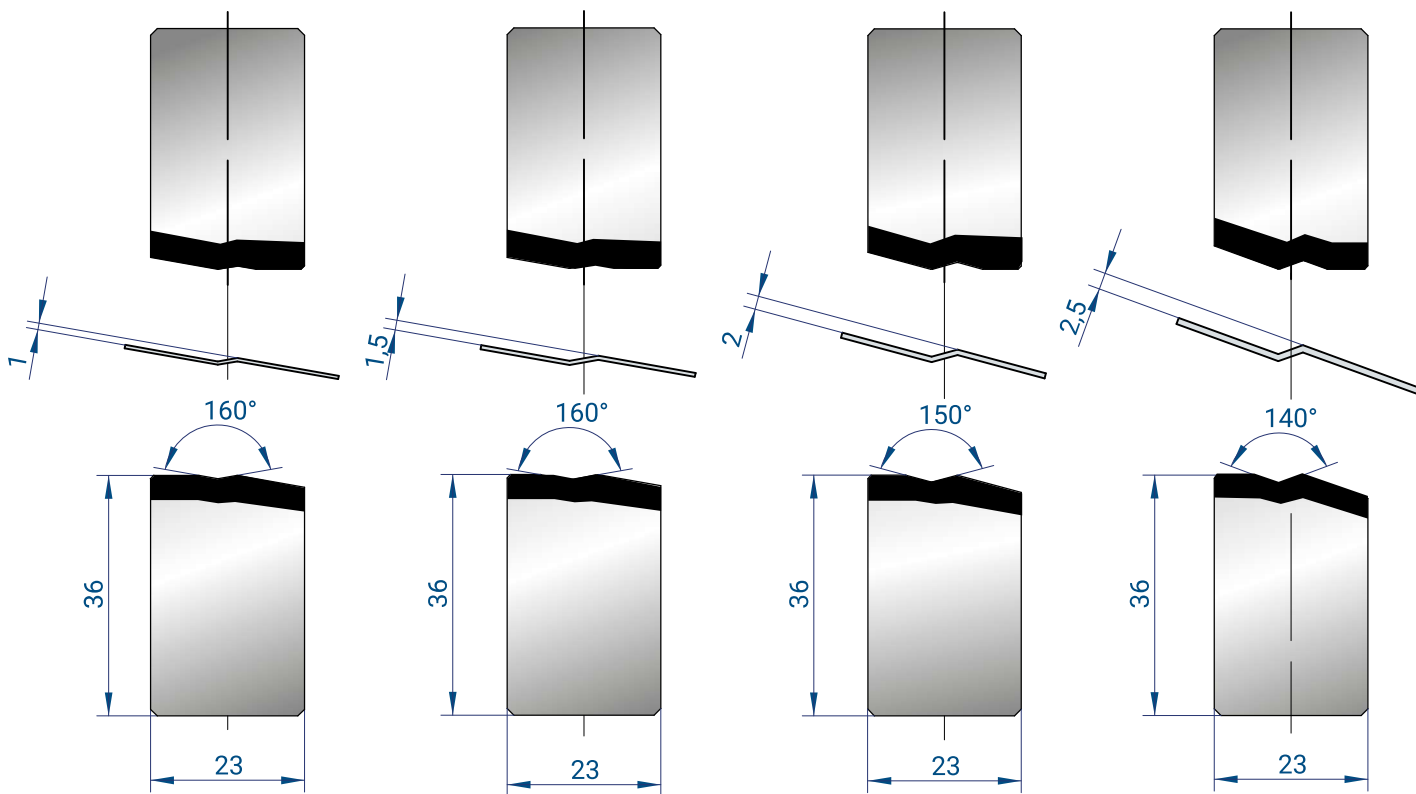

**1130**

160°  
 Mat = C45

835 mm	10,7 kg
415 mm	5,3 kg

**1131**

160°  
 Mat = C45

835 mm	10,7 kg
415 mm	5,3 kg

**1132**

150°  
 Mat = C45

835 mm	10,6 kg
415 mm	5,3 kg

**1133**

140°  
 Mat = C45

835 mm	10,5 kg
415 mm	5,2 kg

PER VERIFICARE LA FATTIBILITÀ DELLA PIEGA IN BASE ALLO SPESSORE LAMIERA, VEDI TABELLA PAGINA 204  
 TO CHOOSE THE RIGHT JOOGLE TOOL BASED ON THE SHEET THICKNESS, PLEASE SEE THE CHART ON PAGE 204



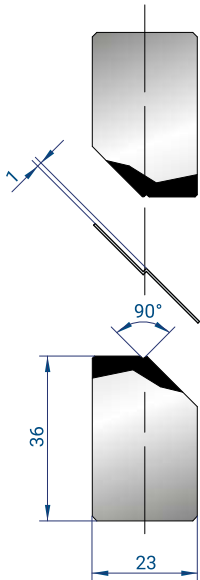

**1276**

90°  
Mat = C45

835 mm	10,0 kg
415 mm	5,0 kg

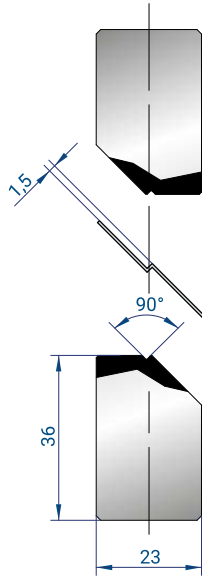

**1277**

90°  
Mat = C45

835 mm	10,0 kg
415 mm	5,0 kg

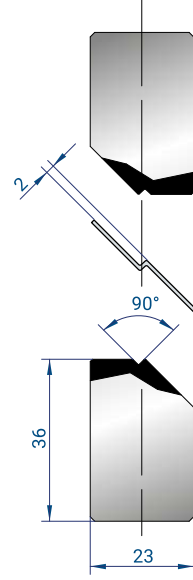

**1274**

90°  
Mat = C45

835 mm	10,0 kg
415 mm	5,0 kg

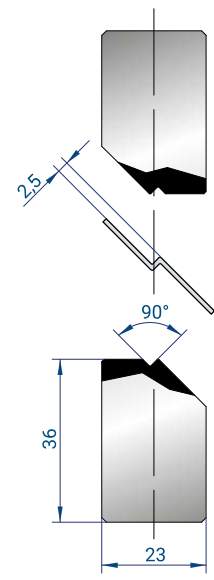

**1275**

90°  
Mat = C45

835 mm	10,1 kg
415 mm	5,0 kg

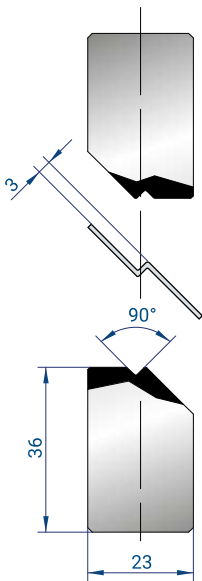

**1134**

90°  
Mat = C45

835 mm	10,1 kg
415 mm	5,0 kg

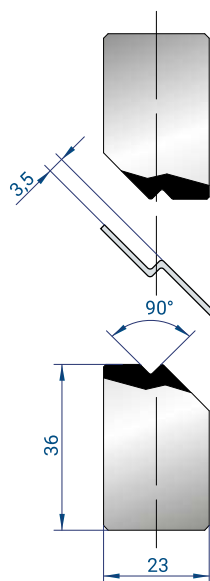

**1135**

90°  
Mat = C45

835 mm	10,1 kg
415 mm	5,0 kg

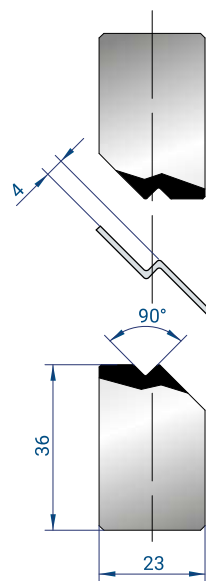

**1136**

90°  
Mat = C45

835 mm	10,1 kg
415 mm	5,0 kg

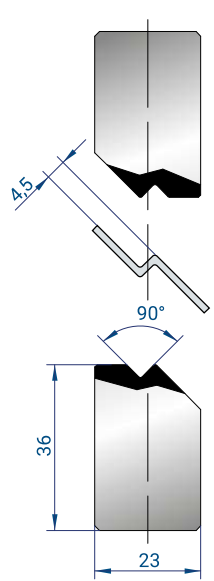

**1137**

90°  
Mat = C45

835 mm	10,1 kg
415 mm	5,0 kg

PER VERIFICARE LA FATTIBILITÀ DELLA PIEGA IN BASE ALLO SPESSORE LAMIERA, VEDI TABELLA PAGINA 204  
TO CHOOSE THE RIGHT JOGGLE TOOL BASED ON THE SHEET THICKNESS, PLEASE SEE THE CHART ON PAGE 204

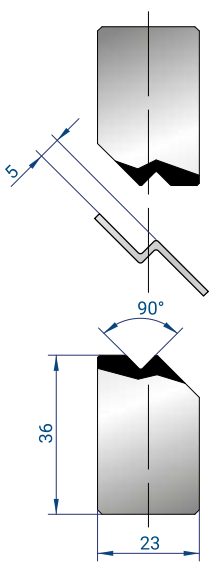

**1138**

90°  
Mat = C45

835 mm	10,1 kg
415 mm	5,0 kg

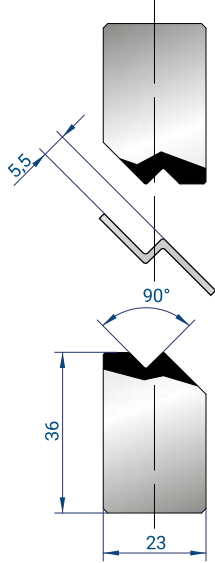

**1139**

90°  
Mat = C45

835 mm	10,1 kg
415 mm	5,0 kg

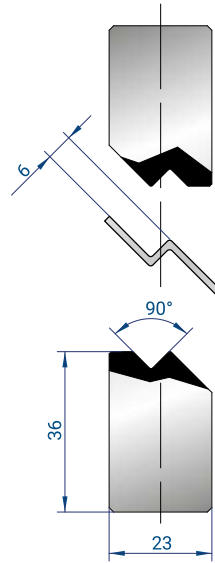

**1140**

90°  
Mat = C45

835 mm	10,1 kg
415 mm	5,0 kg

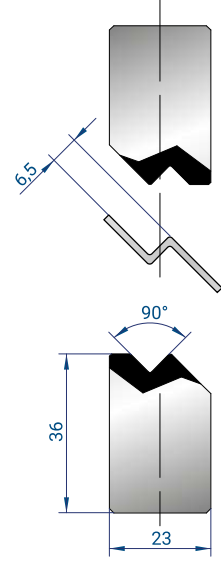

**1141**

90°  
Mat = C45

835 mm	10,0 kg
415 mm	5,0 kg

PER VERIFICARE LA FATTIBILITÀ DELLA PIEGA IN BASE ALLO SPESSORE LAMIERA, VEDI TABELLA PAGINA 204  
TO CHOOSE THE RIGHT JOOGLE TOOL BASED ON THE SHEET THICKNESS, PLEASE SEE THE CHART ON PAGE 204

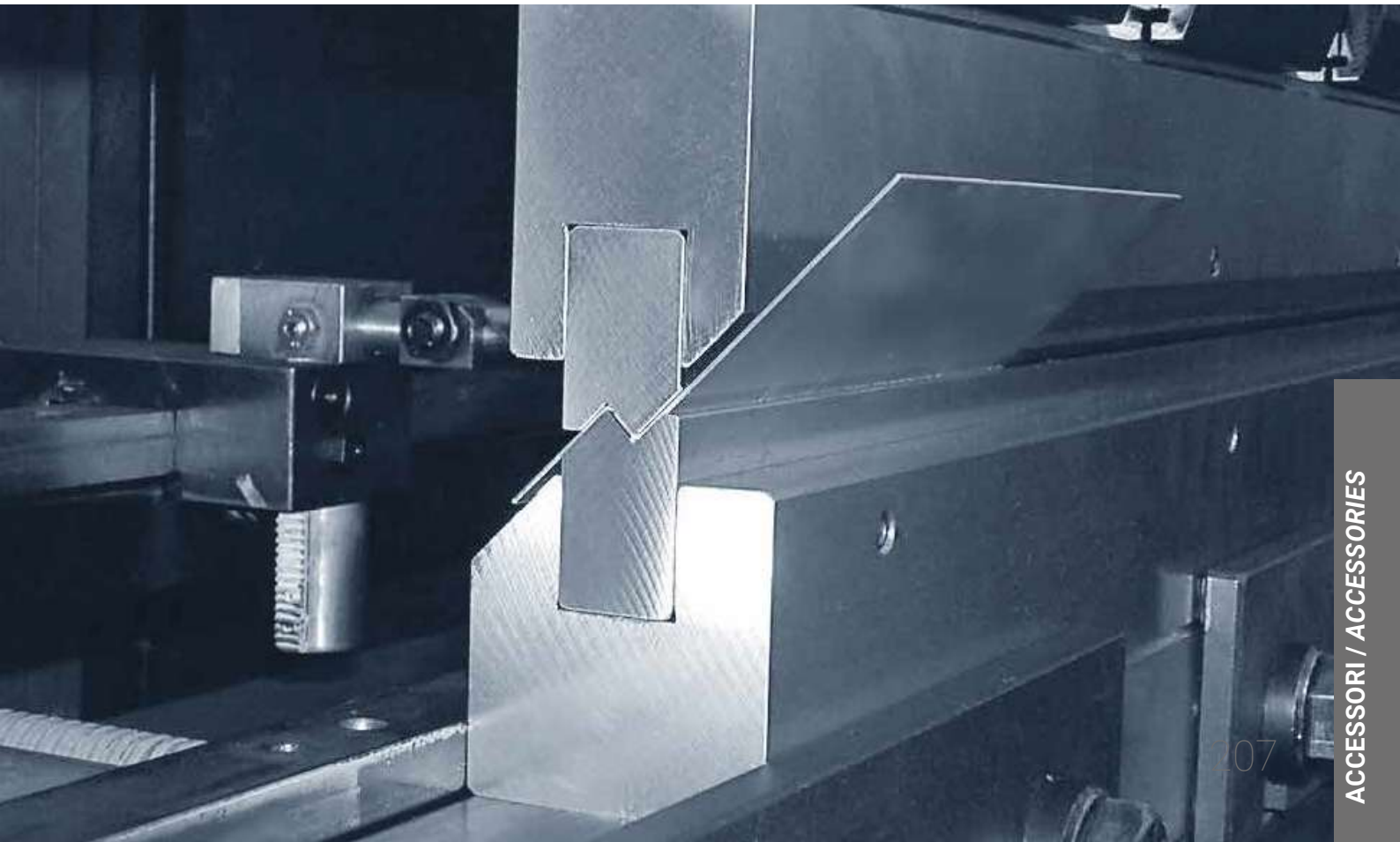

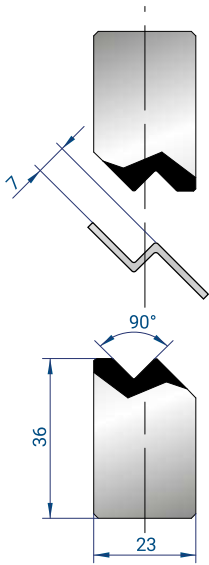

**1142**

90°  
Mat = C45

835 mm	10,0 kg
415 mm	5,0 kg

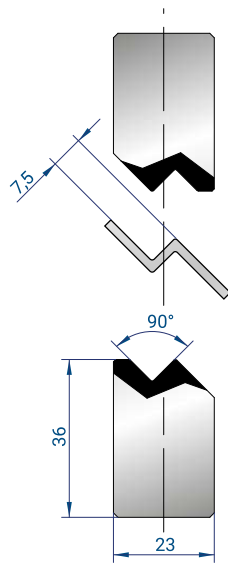

**1143**

90°  
Mat = C45

835 mm	10,0 kg
415 mm	5,0 kg

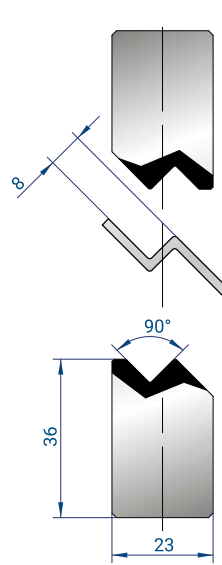

**1144**

90°  
Mat = C45

835 mm	10,0 kg
415 mm	5,0 kg

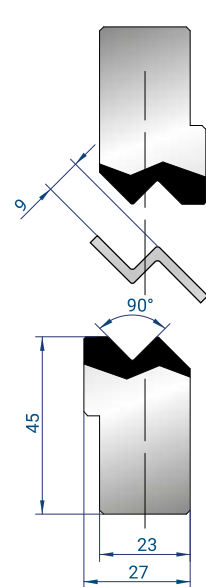

**1145**

90°  
Mat = C45

835 mm	13,6 kg
415 mm	6,8 kg

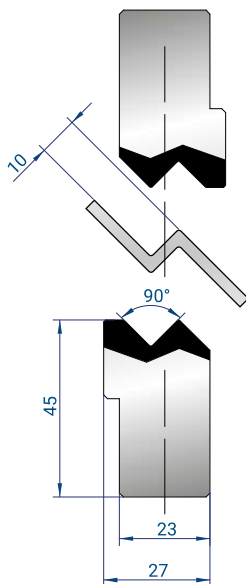

**1146**

90°  
Mat = C45

835 mm	13,6 kg
415 mm	6,7 kg

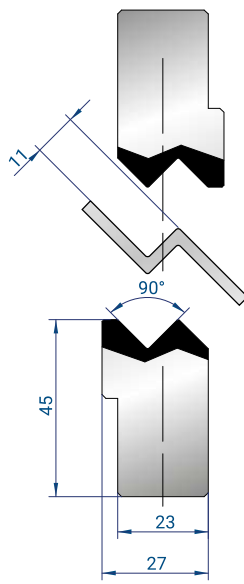

**1147**

90°  
Mat = C45

835 mm	13,5 kg
415 mm	6,7 kg

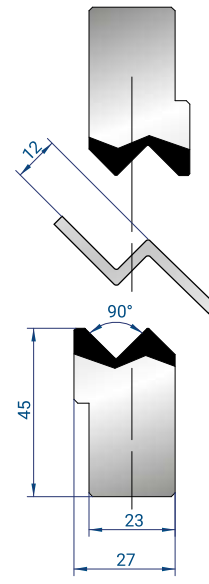

**1148**

90°  
Mat = C45

835 mm	13,3 kg
415 mm	6,6 kg

PER VERIFICARE LA FATTIBILITÀ DELLA PIEGA IN BASE ALLO SPESSORE LAMIERA, VEDI TABELLA PAGINA 204  
TO CHOOSE THE RIGHT JOOGLE TOOL BASED ON THE SHEET THICKNESS, PLEASE SEE THE CHART ON PAGE 204

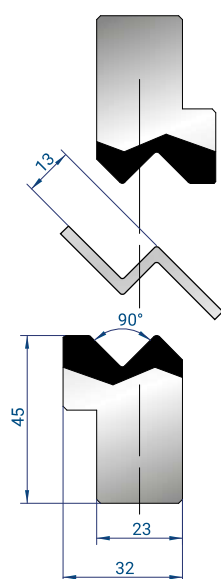

**1278**

90°  
Mat = C45

835 mm	14,6 kg
415 mm	7,3 kg

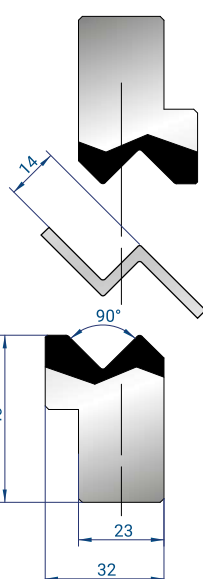

**1279**

90°  
Mat = C45

835 mm	14,5 kg
415 mm	7,3 kg

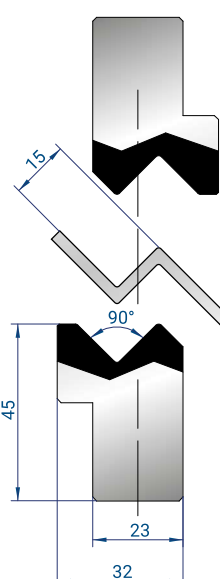

**1280**

90°  
Mat = C45

835 mm	14,3 kg
415 mm	7,1 kg

PER VERIFICARE LA FATTIBILITÀ DELLA PIEGA IN BASE ALLO SPESSORE LAMIERA, VEDI TABELLA PAGINA 204  
TO CHOOSE THE RIGHT JOOGLE TOOL BASED ON THE SHEET THICKNESS, PLEASE SEE THE CHART ON PAGE 204

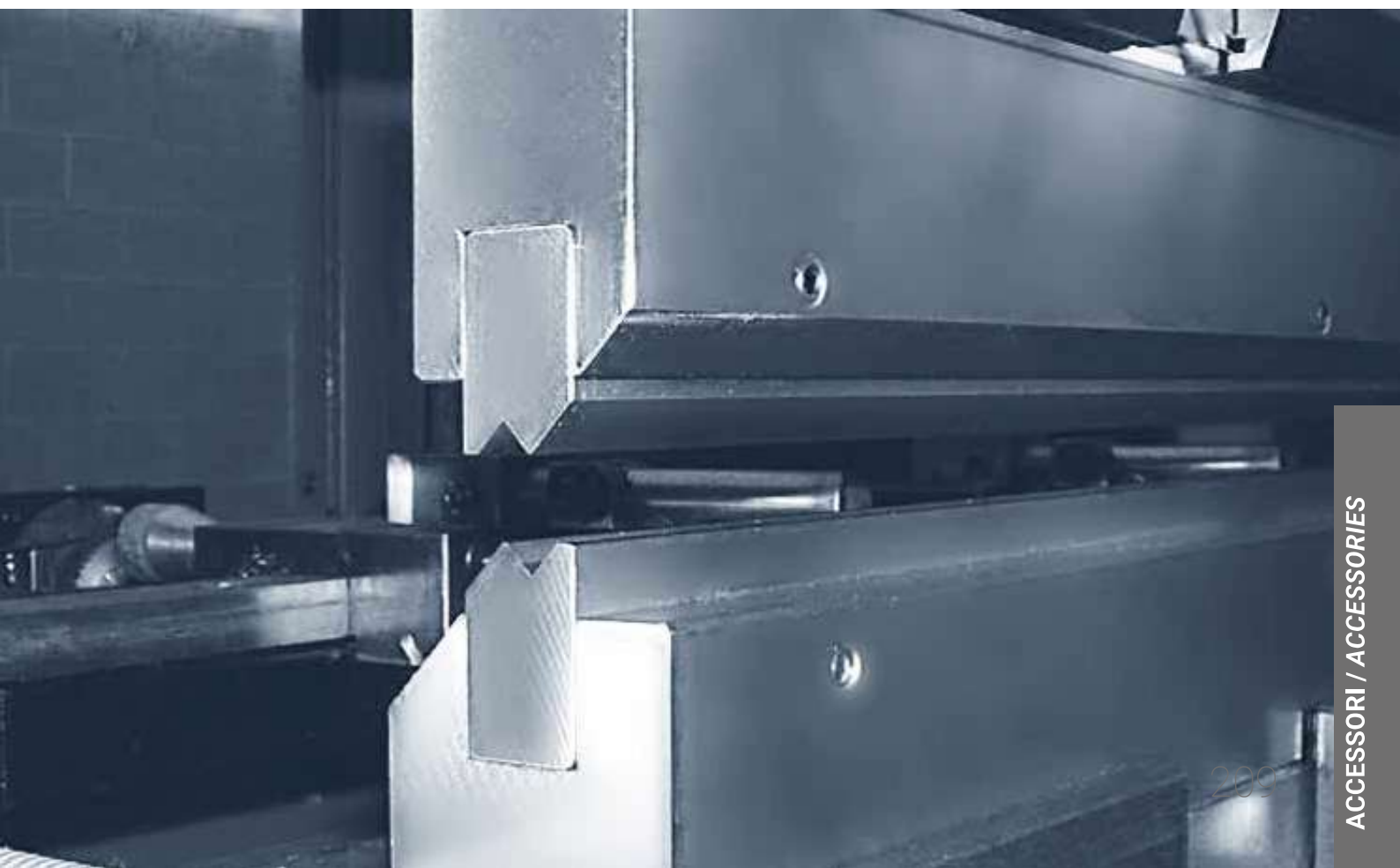

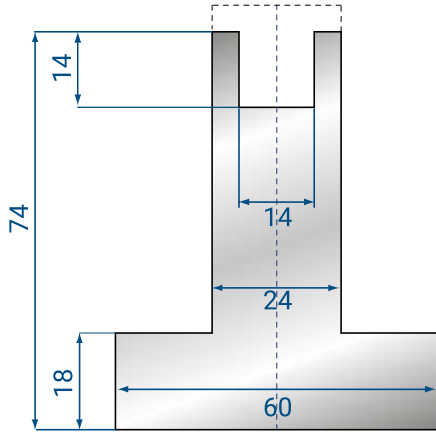

### 2109

AMADA STYLE

835 mm	14,5 kg
415 mm	7,2 kg

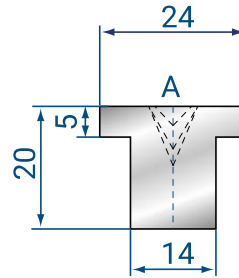

### 2112

835 mm	0,3 kg
415 mm	0,2 kg

A	V		
88°	6	8	10
60°	6	8	10
45°	6	8	10
30°	6	8	

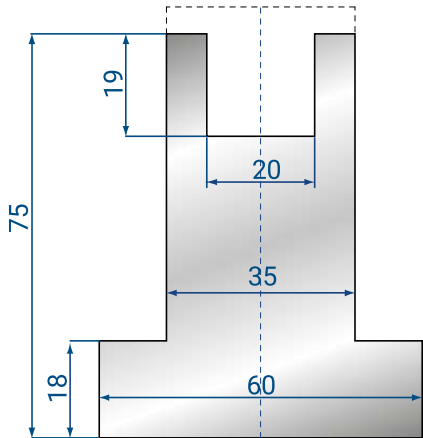

### 2110

AMADA STYLE

835 mm	17,6 kg
415 mm	8,7 kg

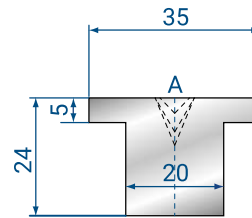

### 2113

835 mm	0,6 kg
415 mm	0,3 kg

A	V				
88°	6	8	10	12	16
60°	6	8	10	12	16
45°	6	8	10	12	
30°	6	8	10		

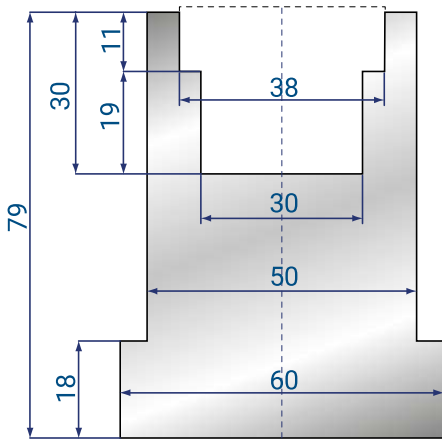

### 2111

AMADA STYLE

835 mm	20,5 kg
415 mm	10,2 kg

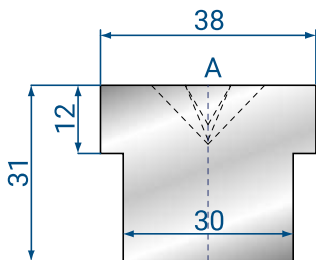

### 2114

835 mm	1,0 kg
415 mm	0,5 kg

A	V						
88°	6	8	10	12	16	20	25
60°	6	8	10	12	16	20	
45°	6	8	10	12	16	20	
30°	6	8	10	12	16		

### 2115

BYSTRONIC TRUMPF WILA STYLE

H = 50

835 mm	10,6 kg
415 mm	5,3 kg

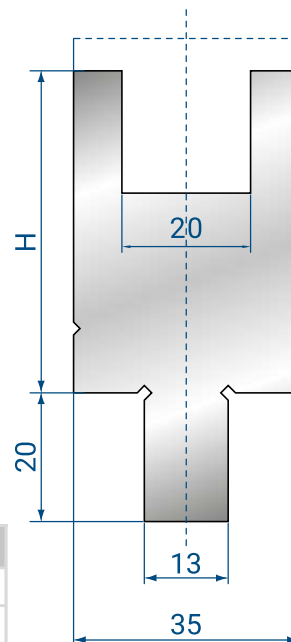

### 2116

BYSTRONIC TRUMPF WILA STYLE

H = 95

835 mm	20,9 kg
415 mm	10,4 kg

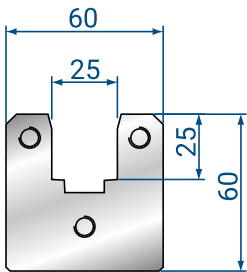

## 2036

AMADA STYLE

835 mm	19,3 kg
415 mm	9,8 kg

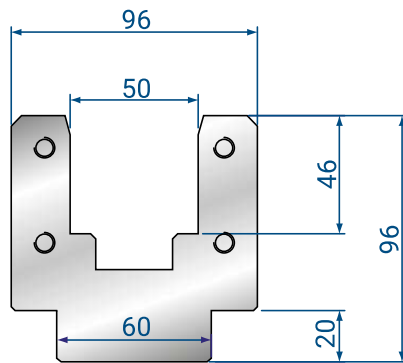

## 2037

AMADA STYLE

835 mm	37,0 kg
415 mm	18,0 kg

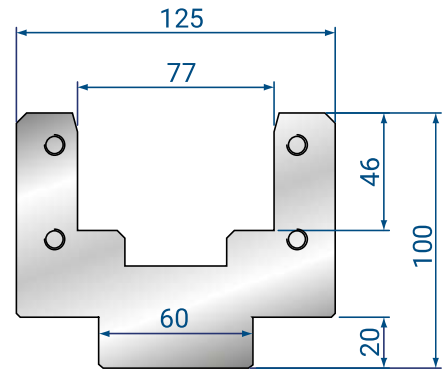

## 2038

AMADA STYLE

835 mm	45,0 kg
415 mm	22,0 kg

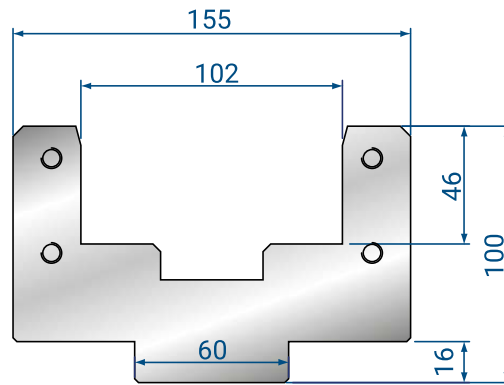

## 2040

AMADA STYLE

835 mm	55,0 kg
415 mm	27,0 kg

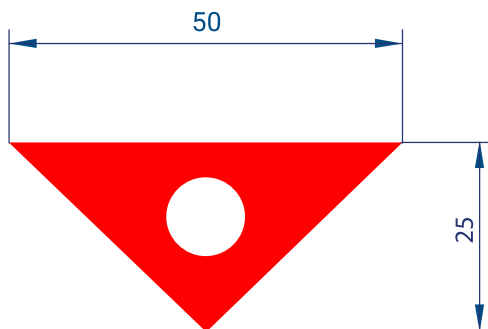

## 2119

**Mat** = Inserto in poliuretano triangolare forato/  
*Perforated triangular polyurethane insert*  
**H** = 25.00  
**v** = 50.00

835 mm	0,6 kg
415 mm	0,3 kg

CONTENITORI E INSERTI IN POLIURETANO  
POLYURETHANE INSERTS AND HOLDER

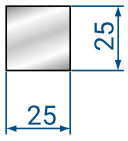

**2101**

92 SHORE

835 mm	0,5 kg
415 mm	0,3 kg

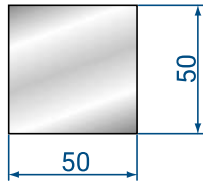

**2102**

92 SHORE

835 mm	2,2 kg
415 mm	1,1 kg

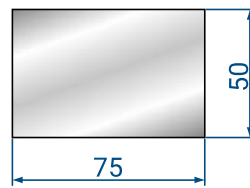

**2103**

92 SHORE

835 mm	3,3 kg
415 mm	1,6 kg

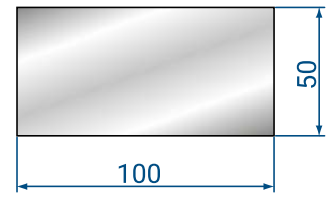

**2104**

92 SHORE

835 mm	4,4 kg
415 mm	2,2 kg

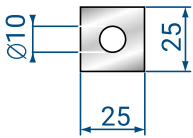

**2105**

92 SHORE

835 mm	0,5 kg
415 mm	0,2 kg

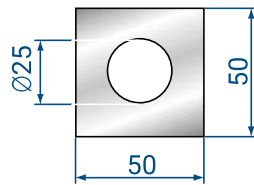

**2106**

92 SHORE

835 mm	1,8 kg
415 mm	0,9 kg

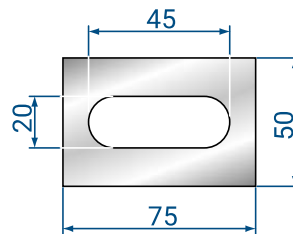

**2107**

92 SHORE

835 mm	2,6 kg
415 mm	1,3 kg

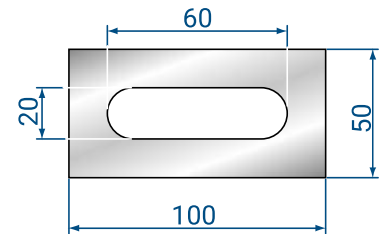

**2108**

92 SHORE

835 mm	3,4 kg
415 mm	1,7 kg



## COMPLETO SISTEMA DI CONNESSIONE PER UTENSILI SUPERIORI STILE EUROPEO (STILE AMADA/PROMECAM) COMPLETE CLAMPING SYSTEM FOR EUROPEAN STYLE TOOLING (AMADA/PROMECAM STYLE)

### PROCESSO DI SOSTITUZIONE UTENSILI CON SISTEMI TRADIZIONALI

Il sistema tradizionale prevede di installare gli utensili superiori tramite staffe di sicurezza avvitate agli intermediari connessi alla tavola superiore.

Il dente presente sulla staffa dell'intermediario lavora nella cava di sicurezza fresata sul punzone per impedirne la caduta accidentale, ma costringe ad inserire/estrarre ogni utensile dal lato macchina e a trascinarlo in posizione operativa.

Quando i punzoni sono posizionati correttamente è necessario pre-serrare le staffe, poi "chiudendo" la macchina, si sollevano e spingono gli utensili a contatto con gli intermediari per allinearli ottimamente.

Il tempo per eseguire questa operazione viene sottratto al tempo di piegatura e può assumere una importanza rilevante nel calcolo della produttività.

### ACTUAL TOOLING REPLACEMENT PROCEDURE

The standard system requires to install the upper tooling through safety clamps screwed on the intermediates connected to the upper machine table.

The clamps safety tang engages into the safety groove machined on the punch front: this combination ensures the tools will not drop out of the clamp when opened to replace them. In order to remove or insert punch tooling, one has to slide the tools horizontally, along the machine length, to the left or right from/to its working position. Note the tools cannot be removed or inserted vertically with this safety feature.

Once the new punches are correctly inserted it is necessary to follow the procedure below:

- slightly tighten all the clamp screws,
- lower the upper beam and push the tooling against their reference surface (bottom side of intermediate), this ensures alignment of the punch tooling,
- finally, firmly tighten all the clamp screws

The average time required to perform the above operation is deducted from the fabrication time, the time taken can be of high importance and relevance when productivity output is a consideration.

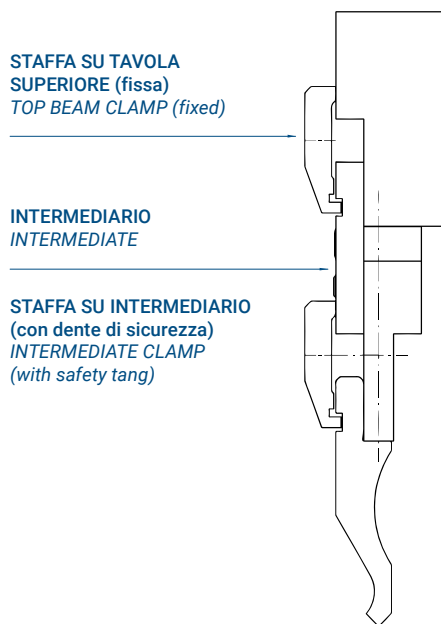
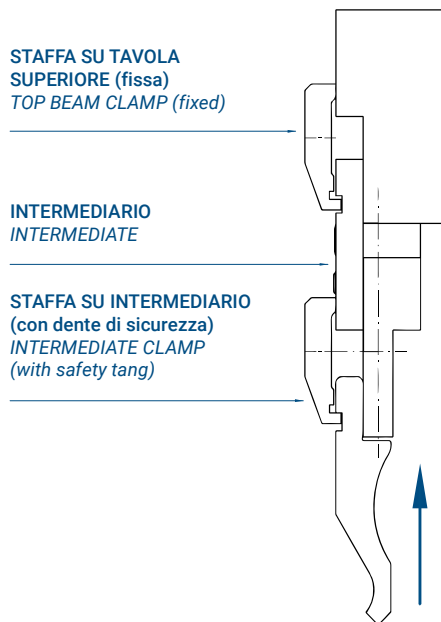
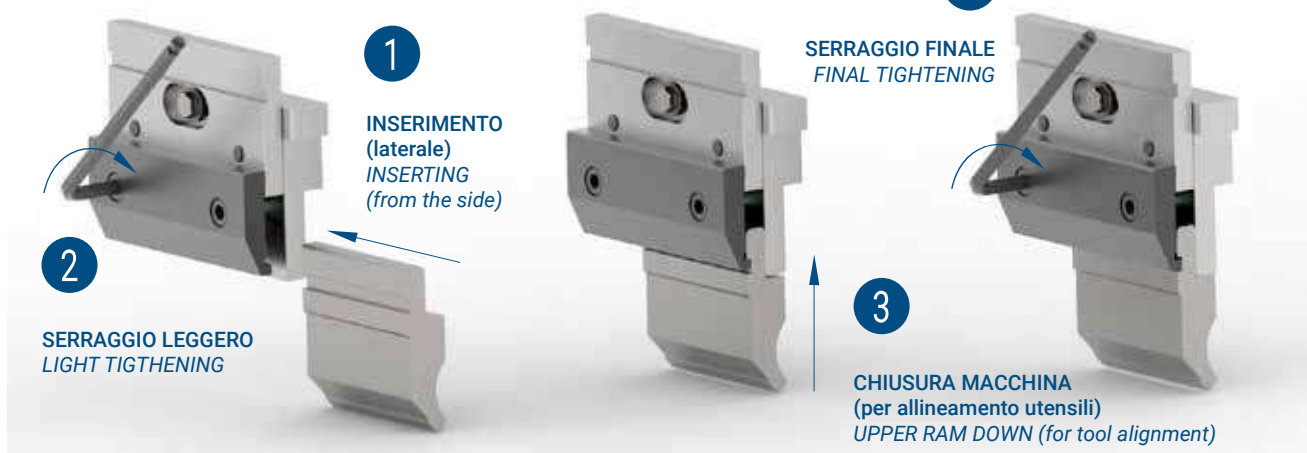

## L'INNOVAZIONE EUROGRIP / THE EUROGRIP INNOVATION

La struttura meccanica della staffa Eurogrip è stata ingegnerizzata per consentire:

- l'inserimento/rimozione del punzone in senso verticale (anziché dal lato macchina) e, contemporaneamente, la garanzia del medesimo elevato livello di sicurezza.
- Il sollevamento del punzone durante la fase di chiusura per arrivare ad allinearli nel momento del bloccaggio finale.

The main innovation is the Eurogrip clamp mechanical structure, engineered for allowing:

- the removal and insertion of punches in vertical direction (instead of sliding them left and right) and, at the same time, for granting the same high safety level.
- The punch lifting during the clamping phase, in order to achieve its right alignment when the clamp is locked.

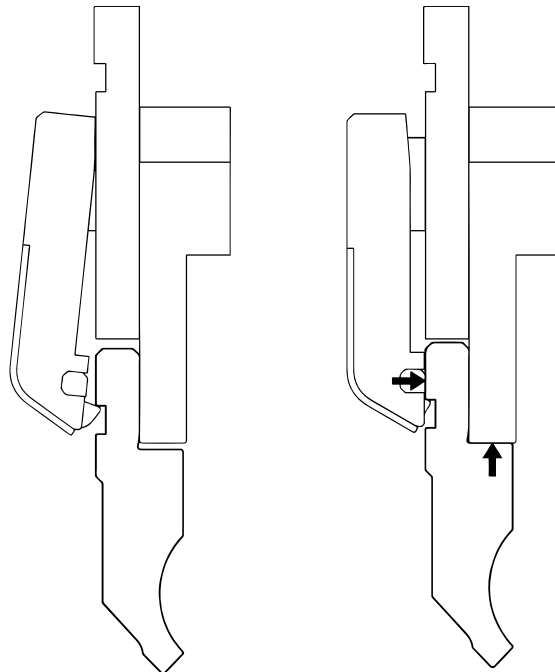

## IL RISPARMIO DI TEMPO / THE TIME SAVING

La tabella mostra i tempi medi necessari per ogni fase dell'operazione di rimozione e sostituzione utensili superiori su una piegatrice de 3 metri (15 intermediari); il suo scopo è la valutazione dei vantaggi offerti dal nuovo sistema.

Comparazione tempi stimati per ogni fase della sostituzione utensili superiori (piegatrice da 3 metri con 15 intermedi).

The table shows the average time required for each phase of any upper tooling removal and replacement operation on a 3-meter-long press brake (15 intermediates); its purpose is the evaluation of the advantages offered by the new system.

Comparison of estimated time required for each phase of an upper tooling replacement operation (press brake 3 meter long - 15 intermediates).

### TEMPO RICHIESTO CON SISTEMA TRADIZIONALE

AVERAGE TIME WITH STANDARD SYSTEM

**circa 9,5 minuti**  
about 9,5 minutes

### TEMPO RICHIESTO CON SISTEMA EUROGRIP MANUALE

AVERAGE TIME REQUIRE WITH EUROGRIP MANUAL SYSTEM

**circa 3,0 minuti (-70%)**  
about 3,0 minutes (-70%)

### TEMPO RICHIESTO CON SISTEMA EUROGRIP PNEUMATICO

AVERAGE TIME REQUIRE WITH EUROGRIP PNEUMATIC SYSTEM

**circa 1,5 minuti (-85%)**  
about 1,5 minutes (-85%)

LA PERCENTUALE DI TEMPO NECESSARIO PER UNA SOLA OPERAZIONE DI CAMBIO UTENSILI RISPETTO A UN'ORA DI LAVORO EFFETTIVO COSTITUISCE, RISPETTIVAMENTE:

- 16% con il Sistema Tradizionale
- 5% con Eurogrip Manuale
- 2,5% con Eurogrip Pneumatico

THE SHARE OF TIME REQUIRED FOR EACH TOOL REPLACEMENT OPERATION OVER A 1-HOUR FABRICATION TIME IS, RESPECTIVELY:

- 16% for the standard system
- 5% with Eurogrip Manual
- 2,5% with Eurogrip Pneumatic

FASE OPERATIVA OPERATING PHASE	SISTEMA DI STAFFAGGIO CLAMPING SYSTEM	DESCRIZIONE OPERAZIONE OPERATION DESCRIPTION	TEMPO RICHIESTO REQUIRED TIME		
<b>1</b> <b>APERTURA STAFFE</b> CLAMPS UNLOCKING	Sistema di staffaggio tradizionale (ogni staffa con due viti) <i>Standard clamping system (each clamp with two screws)</i>	Allentamento 30 viti frontali (5 sec. Cad) <i>Untighten 30 allen bolts (5 seconds each)</i>	150		
	Sistema di staffaggio Eurogrip manuale (M-EASY o M-TOP) <i>Eurogrip manual clamping system (M-EASY or M-TOP)</i>	Apertura 15 levette (3 sec. Cad) <i>Unlock 15 handles (3 seconds each)</i>		45	
	Sistema di staffaggio Eurogrip pneumatico (P-EASY o P-TOP) <i>Eurogrip pneumatic clamping system (P-EASY or P-TOP)</i>	Pressione su pulsante per apertura staffe (2 sec.) <i>Button operation for opening the clamps (2 sec)</i>			2
<b>2</b> <b>RIMOZIONE PUNZONI</b> PUNCHES REMOVAL	Sistema di staffaggio tradizionale (ogni staffa con due viti) <i>Standard clamping system (each clamp with two screws)</i>	Trascinamento ed estrazione utensili da lato macchina <i>Tooling sliding and extraction from machine side (3x835 + 1x SECT)</i>	100		
	Sistema di staffaggio Eurogrip manuale (M-EASY o M-TOP) <i>Eurogrip manual clamping system (M-EASY or M-TOP)</i>	Rimozione verticale utensili da fronte macchina <i>Tooling vertical removal from machine front (3x835 + 1x SECT)</i>		50	
	Sistema di staffaggio Eurogrip pneumatico (P-EASY o P-TOP) <i>Eurogrip pneumatic clamping system (P-EASY or P-TOP)</i>	Rimozione verticale utensili da fronte macchina <i>Tooling vertical removal from machine front (3x835 + 1x SECT)</i>			50
<b>3</b> <b>INSERIMENTO PUNZONI</b> PUNCHES INSERTION	Sistema di staffaggio tradizionale (ogni staffa con due viti) <i>Standard clamping system (each clamp with two screws)</i>	Inserimento utensili da lato macchina e trascinamento in posizione <i>Tooling insertion from machine side and sliding to their position (3x835 + 1x SECT)</i>	100		
	Sistema di staffaggio Eurogrip manuale (M-EASY o M-TOP) <i>Eurogrip manual clamping system (M-EASY or M-TOP)</i>	Inserimento verticale utensili da fronte macchina <i>Tooling vertical insertion from machine front (3x835 + 1x SECT)</i>		40	
	Sistema di staffaggio Eurogrip pneumatico (P-EASY o P-TOP) <i>Eurogrip pneumatic clamping system (P-EASY or P-TOP)</i>	Inserimento verticale utensili da fronte macchina <i>Tooling vertical insertion from machine front (3x835 + 1x SECT)</i>			40
<b>4</b> <b>CHIUSURA STAFFE</b> CLAMPS LOCKING		Serraggio lieve 30 viti (4 secondi cad) <i>Light tightening of 30 allen bolts (4 seconds each)</i>	120		
	Sistema di staffaggio tradizionale (ogni staffa con due viti) <i>Standard clamping system (each clamp with two screws)</i>	Chiusura macchina per allineamento utensili <i>Upper ram down for tooling alignment</i>	10		
		Serraggio finale 30 viti (3 secondi cad) <i>Final tightening of 30 allen bolts (3 seconds each)</i>	90		
	Sistema di staffaggio Eurogrip manuale (M-EASY o M-TOP) <i>Eurogrip manual clamping system (M-EASY or M-TOP)</i>	Chiusura 15 levette (3 sec. Cad) <i>Locking 15 handles (3 seconds each)</i>		45	
	Sistema di staffaggio Eurogrip pneumatico (P-EASY o P-TOP) <i>Eurogrip pneumatic clamping system (P-EASY or P-TOP)</i>	Pressione su pulsante per chiusura staffe (2 sec.) <i>Button operation for closing the clamps (2 sec)</i>			2
TEMPO TOTALE PREVISTO / TOTAL ESTIMATED TIME			570 s	180 s	94 s

## PRINCIPIO OPERATIVO / PRINCIPLE OF OPERATIONS

### INSERIMENTO PUNZONE PUNCH LOADING

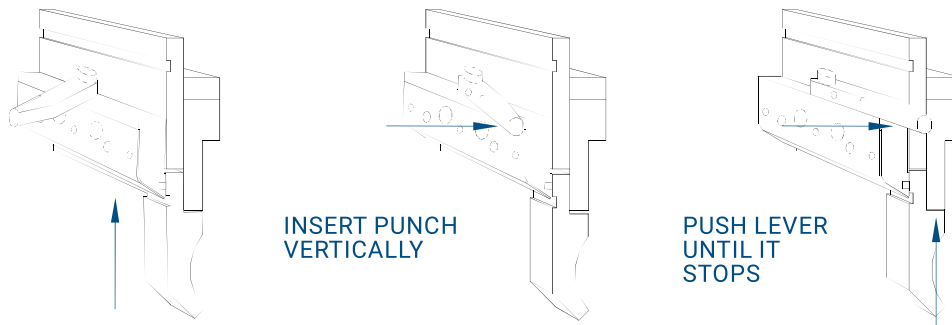

Quando la staffa è in posizione di apertura, permette l'inserimento del punzone in senso verticale verso l'alto fino a quando la cava di sicurezza incontra il meccanismo di sicurezza della staffa, che lo aggancia e lo mantiene sollevato.

Durante il movimento di chiusura della staffa, il meccanismo di sicurezza solleva il punzone fino al piano di riferimento (base dell'intermedio) e lo mantiene in posizione fino alla completa chiusura della staffa che blocca il punzone in posizione.

*When the clamp is in open position, it allows the punch insertion in vertical upward direction until when the punch safety groove engages the clamp safety fingers, that hooks it and keeps the punch in position.*

*During the clamp closing stroke, the safety fingers lifts up the punch until intermediate reference surface and keeps it in the right position until the end of clamp closing movement that locks the punch.*

### RIMOZIONE PUNZONE PUNCH UNLOADING

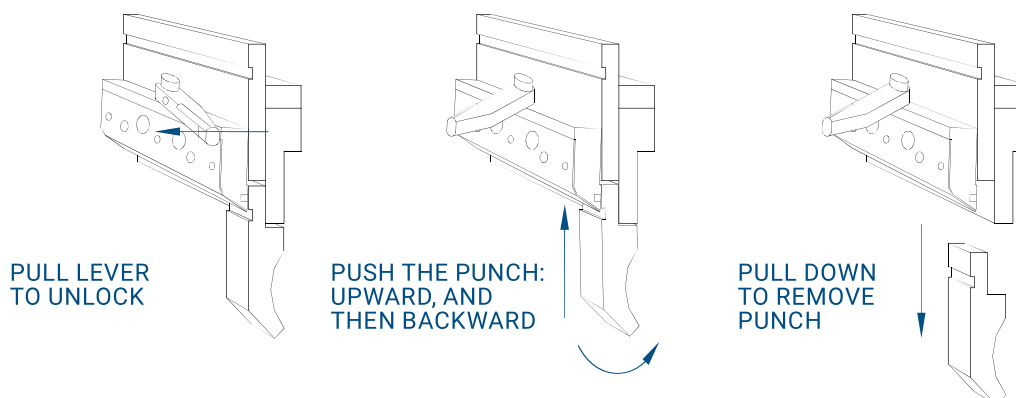

Quando la staffa viene aperta, il punzone viene sbloccato e scende fino ad arrestarsi perché rimane agganciato al meccanismo di sicurezza.

A questo punto è sufficiente sollevare manualmente il punzone e spingere la sua punta verso l'interno della macchina per liberarlo dal meccanismo di sicurezza e sfilarlo in senso verticale verso il basso.

*When the clamp is opened, it unlocks the punch that can then move downwards until the point where it can remain hooked in against the safety fingers.*

*Now it is possible to manually lift the punch upwards and push on its bottom side to disengage it from the safety fingers and removing it in vertical downward direction.*

## LA GAMMA DI PRODOTTI EUROGRIP PER LA CONNESSIONE DEGLI UTENSILI SUPERIORI THE EUROGRIP RANGE FOR THE UPPER TOOL CLAMPING

L'innovativa staffa Eurogrip è alla base della gamma completa di soluzioni sviluppata da Eurostamp, orientata agli equipaggiamenti standard delle piegatrici e alle esigenze specifiche di clienti.

La gamma include Sistemi Manuali e Pneumatici;

ciascun Sistema è disponibile in due Versioni (EASY e TOP);

finalmente, ogni versione comprende due Modelli, in base alle dimensioni degli intermediari originali.

*The innovative Eurogrip clamp is the basis of the complete range of solutions developed by Eurostamp, in line with the press brakes standard equipment and suited to the customer needs.*

*The range includes Manual and Pneumatic, each available in two versions (EASY and TOP);*

*Each version includes two models, according to the dimension of the original intermediates.*

### 1 DIMENSIONI CARATTERISTICHE DI INTERMEDIARIO TIPO Z1

Z1 TYPE INTERMEDIATE TYPICAL DIMENSION

### 2 DIMENSIONI CARATTERISTICHE DI INTERMEDIARIO TIPO Z2

Z2 TYPE INTERMEDIATE TYPICAL DIMENSION

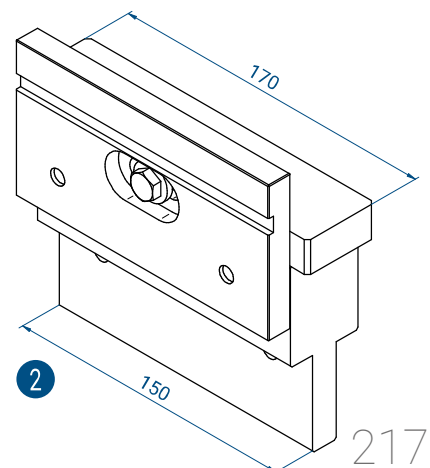
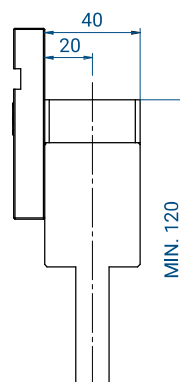
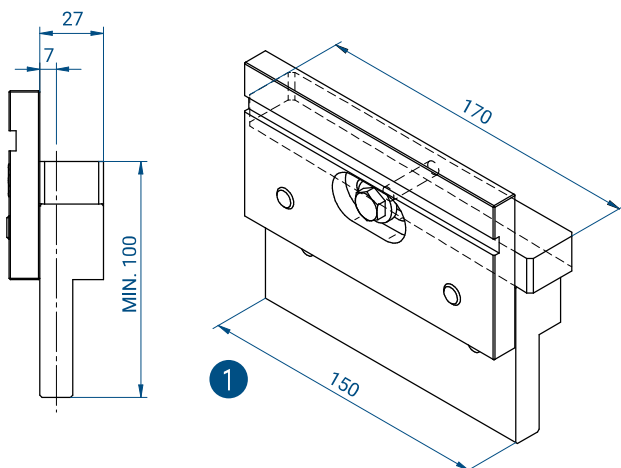

## SISTEMI MANUALI / MANUAL CLAMPING SYSTEMS

### Versione / Version M-EASY

**4389** Dimensioni intermedio / Intermediate dimension **Z1**  
(Corpo / Body: 27mm – Asse / Axis: 7mm) [page 219](#)

**4409** Dimensioni intermedio / Intermediate dimension **Z2**  
(Corpo / Body: 40mm – Asse / Axis: 20mm) [page 220](#)

### Versione / Version M-TOP

**4390** Dimensioni intermedio / Intermediate dimension **Z1**  
(Corpo / Body: 27mm – Asse / Axis: 7mm) [page 221](#)

**4400** Dimensioni intermedio / Intermediate dimension **Z2**  
(Corpo / Body: 40mm – Asse / Axis: 20mm) [page 222](#)

**4419** Dimensioni intermedio / Intermediate dimension **Z1**  
(Corpo / Body: 27mm – Asse / Axis: 7mm) [page 223](#)

**4414** Dimensioni intermedio / Intermediate dimension **Z2**  
(Corpo / Body: 40mm – Asse / Axis: 20mm) [page 224](#)

## SISTEMI PNEUMATICI / PNEUMATIC CLAMPING SYSTEMS

### Versione / Version P-EASY

**4392** Dimensioni intermedio / Intermediate dimension **Z1**  
(Corpo / Body: 27mm – Asse / Axis: 7mm) [page 228](#)

**4405** Dimensioni intermedio / Intermediate dimension **Z2**  
(Corpo / Body: 40mm – Asse / Axis: 20mm) [page 229](#)

### Versione / Version P-TOP

**4399** Dimensioni intermedio / Intermediate dimension **Z1**  
**4398** (Corpo / Body: 27mm – Asse / Axis: 7mm) [page 230 - 231](#)

**4399** Dimensioni intermedio / Intermediate dimension **Z2**  
**4410** (Corpo / Body: 40mm – Asse / Axis: 20mm) [page 230 - 232](#)

### SISTEMI DI STAFFAGGIO MANUALI - INTRODUZIONE MANUAL CLAMPING SYSTEM - INTRODUCTION

Ogni staffa viene operata da una comoda e robusta leva a scomparsa posizionata sulla parte superiore della staffa per evitare qualsiasi interferenza contro la lamiera durante il processo di piegatura.

Lo stesso principio di funzionamento è stato applicato anche ad un adattatore superiore che consente l'installazione di punzoni in stile Trumpf e Wila su macchine con sistema di connessione in stile Europeo (stile Amada/Promecam).

*Each clamp is individually operated by a comfortable and powerful handle, conveniently located on the top in order to avoid any interference with the product being fabricated.*

*We applied a similar solution also to an upper adapter that allows the installation of Wila/Trumpf style punches on machines equipped with European style (Amada/Promecam style) clamping system.*



Modello / Model

**4389**  
(M-EASY Z1)

**SISTEMA MANUALE EUROGRIP M-EASY:**  
STAFFA PER RETROFIT SU INTERMEDIARIO Z1

**MANUAL SYSTEM M-EASY:**  
FRONT CLAMP FOR RETROFIT OF Z1 STYLE INTERMEDIATE

150 mm 0,8 kg



**DESCRIZIONE**

Staffa frontale da installare al posto di quella esistente.

**SPECIFICHE TECNICHE**

Solo su intermediari conformi Z1 (altezza 100mm; corpo 27mm; asse 7mm); tutte le dimensioni dell'intermediario devono essere verificate e confrontate con il disegno tecnico di questa pagina.

**LARGHEZZA MASSIMA UTENSILE = 80MM**  
**PESO MASSIMO UTENSILE = 50KG/MT**

**DESCRIPTION**

Front clamp replacement, installed over the existing intermediate in place of the "standard one".

**TECHNICAL SPECIFICATIONS**

Only on Z1 style intermediates (height 100mm; body width 27mm; bending axis located at 7mm). All dimensions of the intermediates need to be verified and confirmed as per the drawings on this page.

**MAXIMUM TOOL WIDTH = 80MM**  
**MAX TOOL WEIGHT = 50KG/MT**

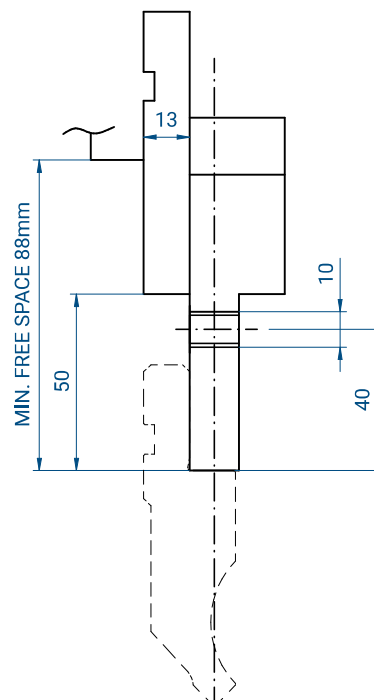
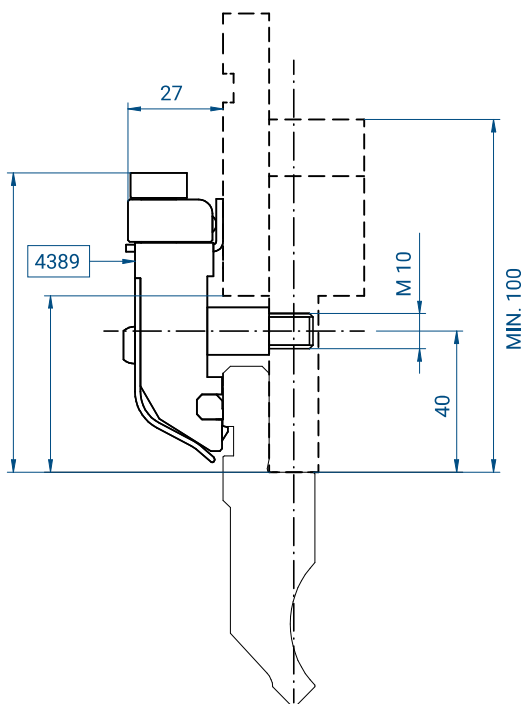

Modello / Model

**4409**  
(M-EASY Z2)

**SISTEMA MANUALE EUROGRIP M-EASY: ASSIEME DI STAFFA + PIASTRA ANTERIORE PER RETROFIT SU INTERMEDIARIO Z2**

**MANUAL SYSTEM M-EASY: ASSEMBLY OF CLAMP + FRONT PLATE FOR RETROFIT OF Z2 STYLE INTERMEDIATE**

150 mm 0,8 kg



**DESCRIZIONE**

Assieme costituito dalla staffa 4389 e da una piastra anteriore, che deve essere installata sul corpo principale dell'intermediario esistente.

**SPECIFICHE TECNICHE**

Solo su intermediari conformi Z2 (altezza minima 120mm; corpo 40mm; asse 20mm). Tutte le dimensioni dell'intermediario devono essere verificate e confrontate con il disegno tecnico di questa pagina.

**LARGHEZZA MASSIMA UTENSILE = 80MM**  
**PESO MASSIMO UTENSILE = 50KG/MT**

**DESCRIPTION**

Assembly made up with clamp model 4389 and by a replacement front plate that must be installed onto the original intermediate.

**TECHNICAL SPECIFICATIONS**

Only on Z2 style intermediates (minimum height 120mm; body width 40mm; bending axis located at 20mm). All dimensions of the intermediates need to be verified and confirmed as per the drawings on this page.

**MAXIMUM TOOL WIDTH = 80MM**  
**MAX TOOL WEIGHT = 50KG/MT**

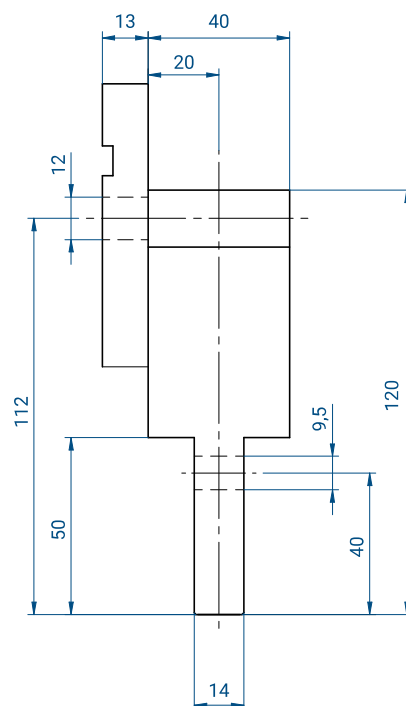
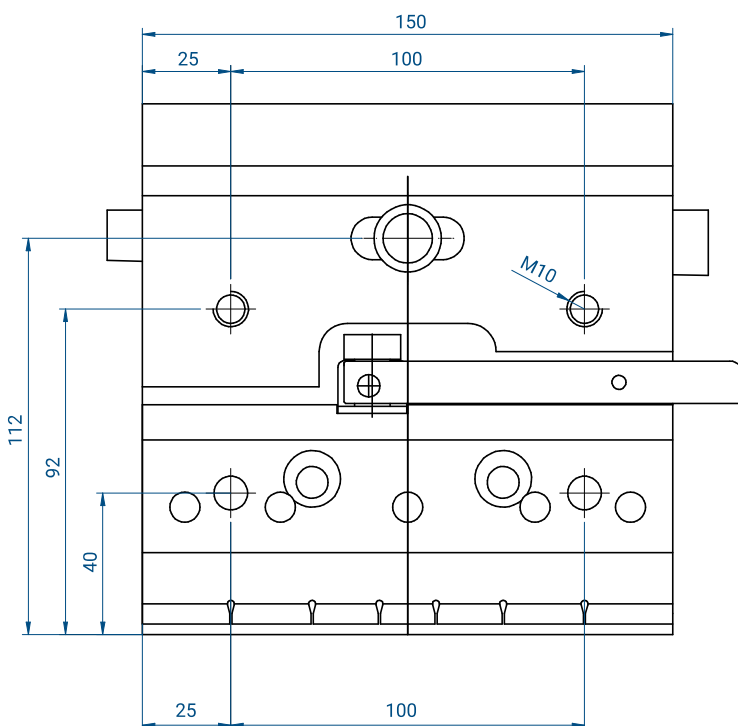

Modello / Model

**4390**  
(M-TOP Z1)

**SISTEMA MANUALE EUROGRIP M-TOP:**  
STAFFA ASSEMBLATA SU INTERMEDIO SPECIFICO Z1

**EUROGRIP MANUAL SYSTEM M-TOP:**  
FRONT CLAMP ASSEMBLED ON SPECIFIC Z1 STYLE INTERMEDIATE

150 mm 5,2 kg

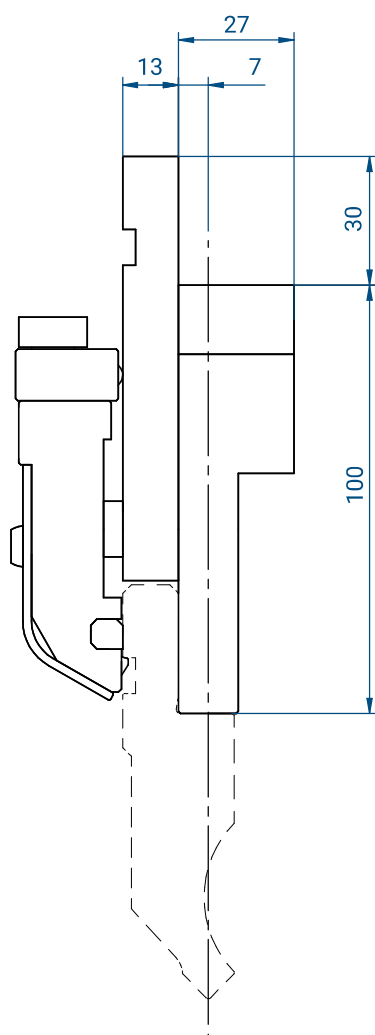

## DESCRIZIONE

Assieme completo costituito da una speciale staffa manuale (dimensioni maggiorate) installata su un intermedio speciale (Z1) di alta qualità, disegnato per alloggiare la staffa maggiorata.

Soluzione privilegiata nei casi in cui sia necessario sostituire gli intermedi esistenti perché danneggiati e quando le dimensioni dell'intermedio esistente non consentano l'utilizzo di M-EASY.

Il codice 4390 è già predisposto per l'installazione delle staffe manuali posteriori opzionali codice 4404 (fori passanti).

## SPECIFICHE TECNICHE

Solo su macchine predisposte ad installare intermedi di tipo Z1 (altezza 100mm; corpo 27mm; asse 7mm): tutte le dimensioni dell'intermediario devono essere verificate e confrontate con il disegno tecnico di questa pagina.

**LARGHEZZA MASSIMA UTENSILE = 80MM**  
**PESO MASSIMO UTENSILE = 50KG/MT**

## DESCRIPTION

Full intermediate assembly, made up of a special manual clamp (bigger dimension) already installed over a special, superior quality (Z1) intermediate body, designed for the movement of the operating fingers.

This solution is the best choice when a new set of intermediates is replacing the old ones (damaged or worn out) or when the original intermediate dimension does not allow to utilize the M-EASY.

The code 4390 is already set for installing the optional rear clamp manually operated code 4404(pass-through holes).

## TECHNICAL SPECIFICATIONS

Only on machines equipped for Z1 style intermediates (height 100mm; body width 27mm; bending axis located at 7mm). All dimensions of the intermediates need to be verified and confirmed as per the drawings on this page.

**MAXIMUM TOOL WIDTH = 80MM**  
**MAX TOOL WEIGHT = 50KG/MT**

Modello / Model

**4400**  
(M-TOP Z2)

**SISTEMA MANUALE EUROGRIP M-TOP: STAFFA ASSEMBLATA SU INTERMEDIO SPECIFICO Z2**

**EUROGRIP MANUAL SYSTEM M-TOP: FRONT CLAMP ASSEMBLED ON SPECIFIC Z2 STYLE INTERMEDIATE**

150 mm 7,0 kg

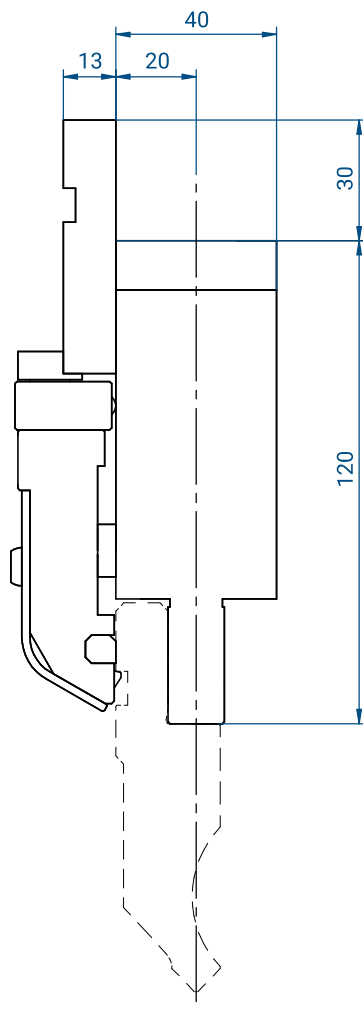

### DESCRIZIONE

Assieme completo costituito da una speciale staffa manuale (dimensioni maggiorate) installata su un intermedio speciale (Z2) di alta qualità disegnato per alloggiare la staffa maggiorata.

Questa soluzione è la scelta migliore quando una nuova serie di intermedi sta sostituendo quelli vecchi (danneggiati o usurati) o quando la dimensione dell'intermedio originale non consente di utilizzare il M-EASY.

Il codice 4400 è già predisposto per l'installazione delle staffe manuali posteriori opzionali codice 4404 (fori passanti).

### SPECIFICHE TECNICHE

Solo su macchine predisposte ad installare intermedi di tipo Z2 (altezza 120mm; corpo 40mm; asse 20mm): tutte le dimensioni dell'intermediario devono essere verificate e confrontate con il disegno tecnico di questa pagina.

Peso=5,5Kg

**LARGHEZZA MASSIMA UTENSILE = 80MM**  
**PESO MASSIMO UTENSILE = 50KG/MT**

### DESCRIPTION

Full intermediate assembly, made up of a special manual clamp (bigger dimension) already installed over a special, superior quality (Z2) intermediate body, conveniently machined for the movement of the operating fingers.

This solution is the best choice when a new set of intermediates is replacing the old ones (damaged or worn out) or when the original intermediate dimension does not allow to utilize the M-EASY.

The code 4400 is already set for installing the optional rear clamp manually operated code 4404 (pass-through holes).

### TECHNICAL SPECIFICATIONS

Only on machines equipped for Z2 style intermediates (height 120mm; body width 40mm; bending axis located at 7mm). All dimensions of the intermediates need to be verified and confirmed as per the drawings on this page.

Weight=5,5Kg

**MAXIMUM TOOL WIDTH = 80MM**  
**MAX TOOL WEIGHT = 50KG/MT**

Modello / Model

**4419**  
Z1 (M-TOP Z1 DUO)

**SISTEMA MANUALE EUROGRIP M-TOP Z1 DUO: STAFFE ASSEMBLATE SU INTERMEDIO SPECIFICO Z2**

**EUROGRIP MANUAL SYSTEM M-TOP Z1 DUO: FRONT CLAMPS ASSEMBLED ON SPECIFIC Z2 STYLE INTERMEDIATE**

150 mm 7,0 kg

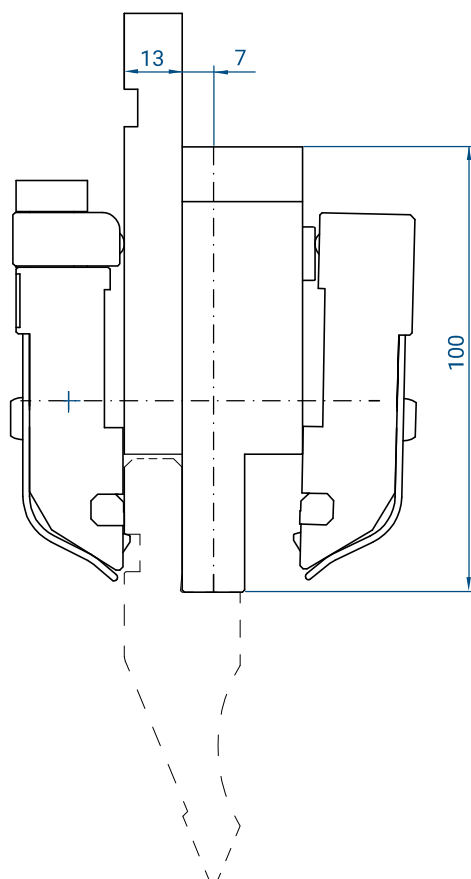
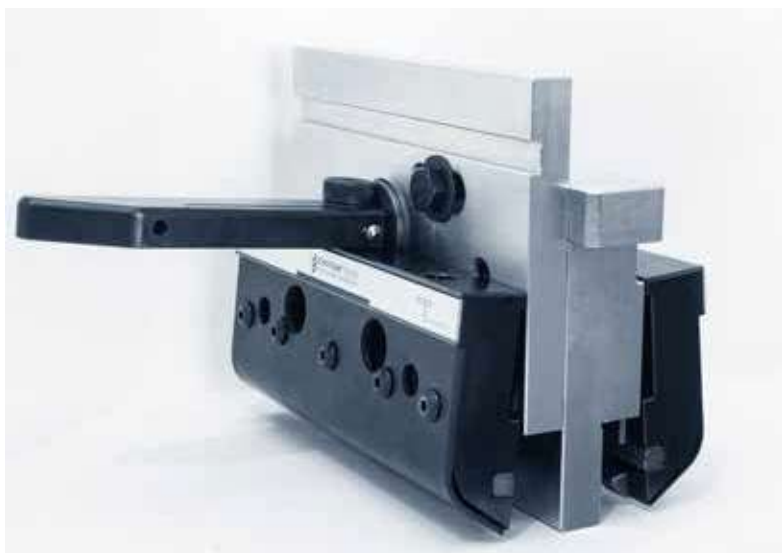

### CARATTERISTICHE TECNICHE

Ogni singolo pezzo di utensile può essere montato con orientamento frontale oppure posteriore (rotazione di 180°) in base alla necessità di piegatura.

Inserimento verticale per entrambe gli orientamenti con aggancio automatico nel sistema aperto. Nessun limite di lunghezza, forma e quantità degli utensili inseriti.

Bloccaggio tramite unica leva per modulo che agisce su tutti gli utensili presenti con sollevamento in appoggio e bloccaggio sui piani di riferimento a garanzia di un perfetto allineamento. La leva in posizione di bloccaggio non presenta sporgenze.

Sbloccaggio: l'apertura della leva libera tutti gli utensili presenti. Il sistema ne impedisce lo sgancio con assoluta sicurezza.

Estrazione: avviene solamente agendo su ogni singolo pezzo con sollevamento in battuta, piccola rotazione e sfilamento verso il basso. L'operazione non richiede sforzi aggiuntivi oltre al peso dell'utensile.

**LARGHEZZA MASSIMA UTENSILE = 80MM**  
**PESO MASSIMO UTENSILE = 50KG/MT**

### TECHNICAL FEATURES

Each tool can be mounted in either front or reverse orientation (180° rotation) depending on the bending requirement.

Vertical insertion for both orientations with automatic docking when clamps are in "open" position. No limits on the length, shape and quantity of the tools inserted.

Locking by means of a single lever per module that acts on all tools present with lift-off and clamping on the reference planes to guarantee perfect alignment. The lever in the clamping position has no protrusions.

Unlocking: the opening of the lever frees all the tools present. The clamps safety system prevents them from being unhooked with absolute safety.

Extraction: it is performed by lifting upward the punch and tilting it forward. Once unlocked it can be removed safely sustaining only the tool weight.

**MAXIMUM TOOL WIDTH = 80MM**  
**MAX TOOL WEIGHT = 50KG/MT**

Modello / Model

**4414**  
Z2 (M-TOP Z2 DUO)

**SISTEMA MANUALE EUROGRIP M-TOP Z2 DUO: STAFFE ASSEMBLATE SU INTERMEDIO SPECIFICO Z2**

**EUROGRIP MANUAL SYSTEM M-TOP Z2 DUO: FRONT CLAMPS ASSEMBLED ON SPECIFIC Z2 STYLE INTERMEDIATE**

150 mm 7,0 kg

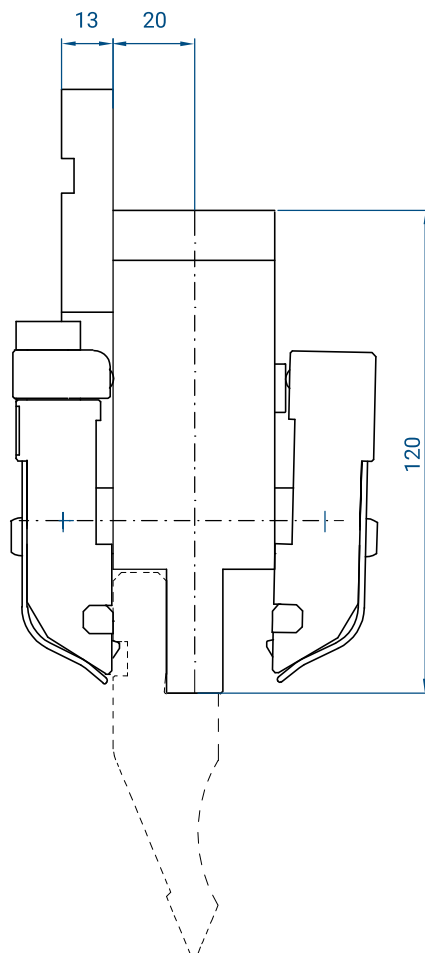

#### CARATTERISTICHE TECNICHE

Ogni singolo pezzo di utensile può essere montato con orientamento frontale oppure posteriore (rotazione di 180°) in base alla necessità di piegatura.

Inserimento verticale per entrambe gli orientamenti con aggancio automatico nel sistema aperto. Nessun limite di lunghezza, forma e quantità degli utensili inseriti.

Bloccaggio tramite unica leva per modulo che agisce su tutti gli utensili presenti con sollevamento in appoggio e bloccaggio sui piani di riferimento a garanzia di un perfetto allineamento. La leva in posizione di bloccaggio non presenta sporgenze.

Sbloccaggio: l'apertura della leva libera tutti gli utensili presenti. Il sistema ne impedisce lo sgancio con assoluta sicurezza.

Estrazione: avviene solamente agendo su ogni singolo pezzo con sollevamento in battuta, piccola rotazione e sfilamento verso il basso. L'operazione non richiede sforzi aggiuntivi oltre al peso dell'utensile.

**LARGHEZZA MASSIMA UTENSILE = 80MM**  
**PESO MASSIMO UTENSILE = 50KG/MT**

#### TECHNICAL FEATURES

Each tool can be mounted in either front or reverse orientation (180° rotation) depending on the bending requirement.

Vertical insertion for both orientations with automatic docking when clamps are in "open" position. No limits on the length, shape and quantity of the tools inserted.

Locking by means of a single lever per module that acts on all tools present with lift-off and clamping on the reference planes to guarantee perfect alignment. The lever in the clamping position has no protrusions.

Unlocking: the opening of the lever frees all the tools present. The clamps safety system prevents them from being unhooked with absolute safety.

Extraction: it is performed by lifting upward the punch and tilting it forward. Once unlocked it can be removed safely sustaining only the tool weight.

**MAXIMUM TOOL WIDTH = 80MM**  
**MAX TOOL WEIGHT = 50KG/MT**

Modello / Model

**4393**  
(M-WDP Z1)

**SISTEMA MANUALE EUROGRIP M-WDP: ADATTATORE SUPERIORE DA STILE AMADA (TIPO Z1) A STILE WILA/TRUMPF**

**EUROGRIP MANUAL SYSTEM M-WDP: UPPER ADAPTER FROM AMADA STYLE (Z1 TYPE) TO WILA/TRUMPF STYLE**

150 mm 6,7 kg

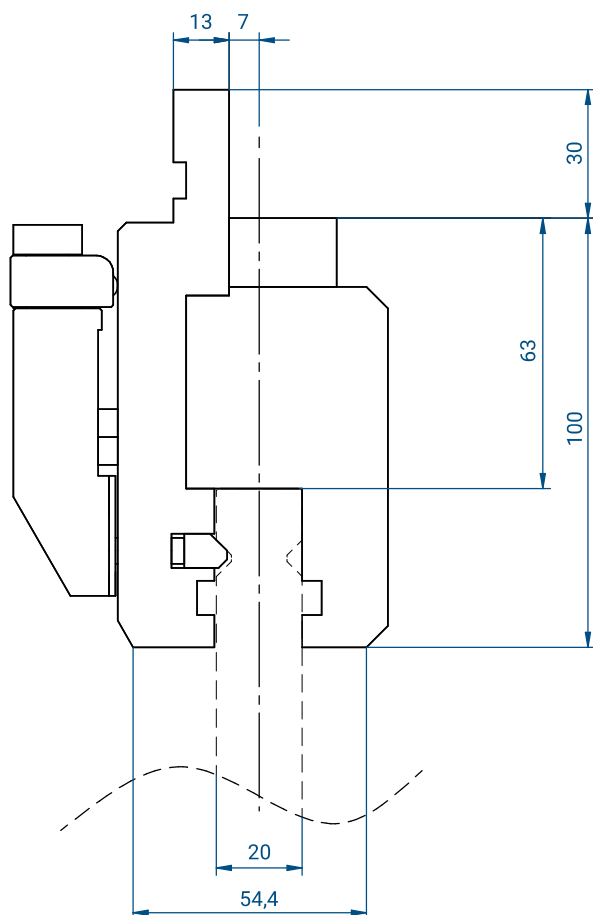
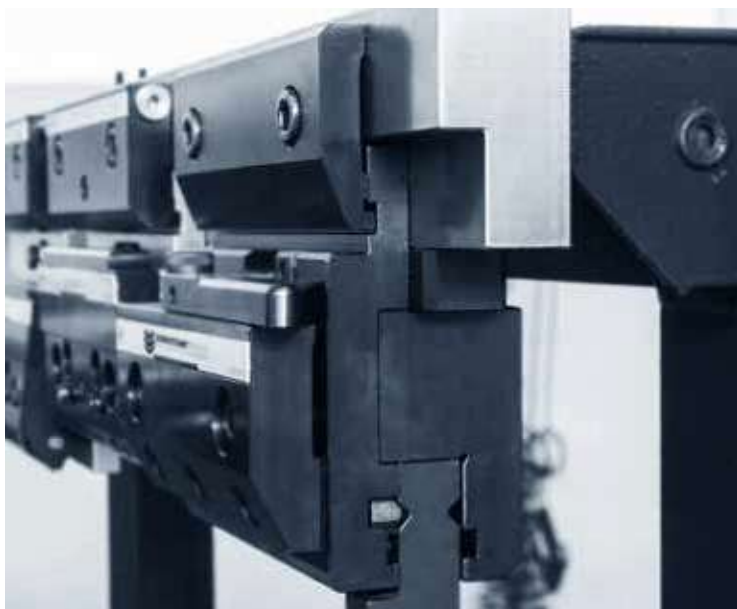

#### DESCRIZIONE

Adattatore speciale da stile standard Amada/Promecam (stile Europeo) a stile standard Trumpf/Wila.

La staffa anteriore - operata da una leva a scomparsa - permette l'inserimento, la rimozione, l'allineamento e il bloccaggio di utensili conformi allo standard Trumpf/Wila su macchine con tavola superiore in stile Europeo (stile Amada Promecam).

#### SPECIFICHE TECNICHE

Solo su macchine predisposte ad installare intermedi di tipo Z1 (altezza 100mm; corpo 27mm; asse 7mm): tutte le dimensioni dell'intermediario devono essere verificate e confrontate con il disegno tecnico di questa pagina.

Peso=6,7Kg.

#### DESCRIPTION

Upper adapter from European style (Amada/Promecam style) to Trumpf/Wila style.

The front clamp, operated by a foldaway handle allows the installation; the removal; the alignment and the locking of Trumpf/Wila style top tooling on a press brake equipped with European style clamping system.

#### TECHNICAL SPECIFICATIONS

Only on machines equipped for Z1 style intermediates (height 100mm; body width 27mm; bending axis located at 7mm). All dimensions of the intermediates need to be verified and confirmed as per the drawings on this page.

Weight=6,7Kg.

SISTEMI DI STAFFAGGIO MANUALI – DISPOSITIVI OPZIONALI  
 MANUAL CLAMPING SYSTEM – OPTIONAL ADD-ONS

Modello / Model

**4408**

150 mm 0,7 kg

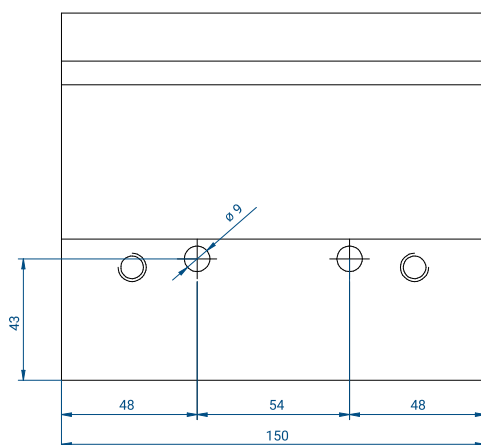
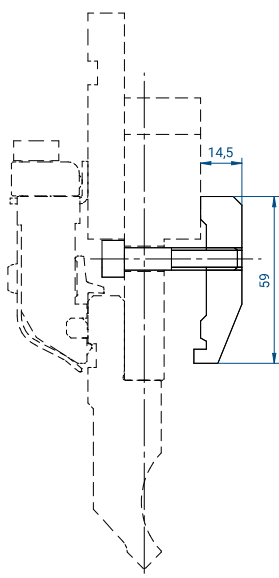

**STAFFA POSTERIORE OPZIONALE, ESCLUSIVA PER MODELLI M-EASY**

Per installare punzoni con orientamento "rovesciato" su intermedi equipaggiati con sistemi M-EASY (4389 e 4409).

La staffa posteriore viene operata da fronte macchina agendo su due viti a brugola.

Per installare la staffa opzionale è necessario eseguire due fori passanti diametro 9mm sul corpo dell'intermedio.

**OPTIONAL REAR CLAMP EXCLUSIVELY FOR M-EASY MODELS**

For inserting the punches in "reverse" direction on intermediates equipped with M-EASY clamps (4389 e 4409).

The rear clamp is operated by standing on the machine front and through two allen-key bolts.

For mounting the rear clamp, two additional holes  $\varnothing 9\text{mm}$  need to be drilled on the intermediate body.

Modello / Model

**4404**

150 mm 0,8 kg

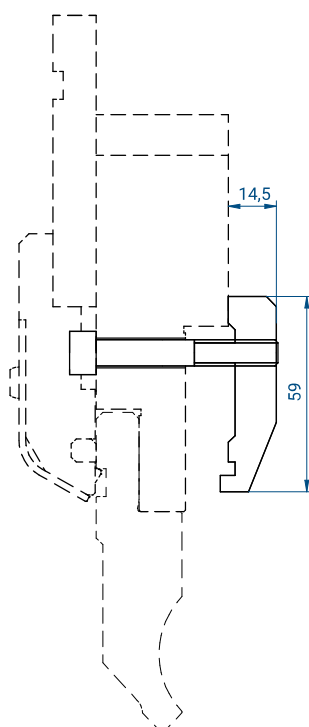
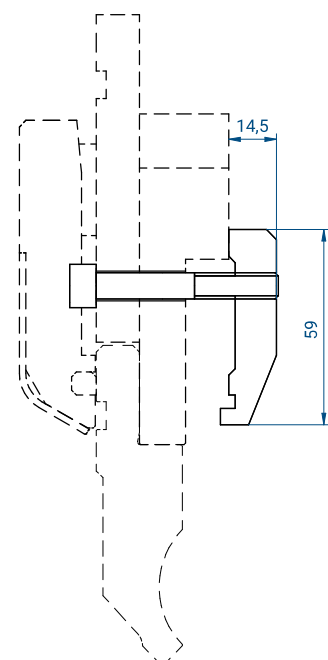

**STAFFA POSTERIORE OPZIONALE, PER MODELLI M-TOP; P-EASY; P-TOP**

Per installare punzoni con orientamento "rovesciato" su intermedi equipaggiati con sistemi M-TOP; P-EASY; P-TOP.

La staffa posteriore viene operata da fronte macchina agendo su due viti a brugola.

Tutti i modelli M-TOP; P-EASY; P-TOP sono forniti completi di fori passanti, per cui non è necessaria alcuna lavorazione aggiuntiva per installare la staffa.

**OPTIONAL REAR CLAMP, FOR MODELS M-TOP; P-EASY; P-TOP**

For inserting the punches in "reverse" direction on intermediates equipped with all the products M-TOP; P-EASY; P-TOP.

The rear clamp is operated by standing on the machine front and through two allen bolts.

All the models M-TOP; P-EASY; P-TOP are supplied with the pass-through holes already drilled on – ne need for any additional operation.

## SISTEMI DI STAFFAGGIO PNEUMATICI - INTRODUZIONE PNEUMATIC CLAMPING SYSTEM - INTRODUCTION

Tutte le staffe presenti sulla tavola superiore sono operate tramite aria compressa, controllata da una centralina e trasferita tramite tubi che collegano in serie gli intermedi.

La gamma di sistemi pneumatici include un sistema analogo per gli utensili inferiori.

*All of the clamps located on the machine upper table are operated by compressed air, managed by a pneumatic control unit and transferred through pipes that connect serially the intermediates.*

*The pneumatic system product range includes also a solution for the pneumatic clamping of lower tooling.*

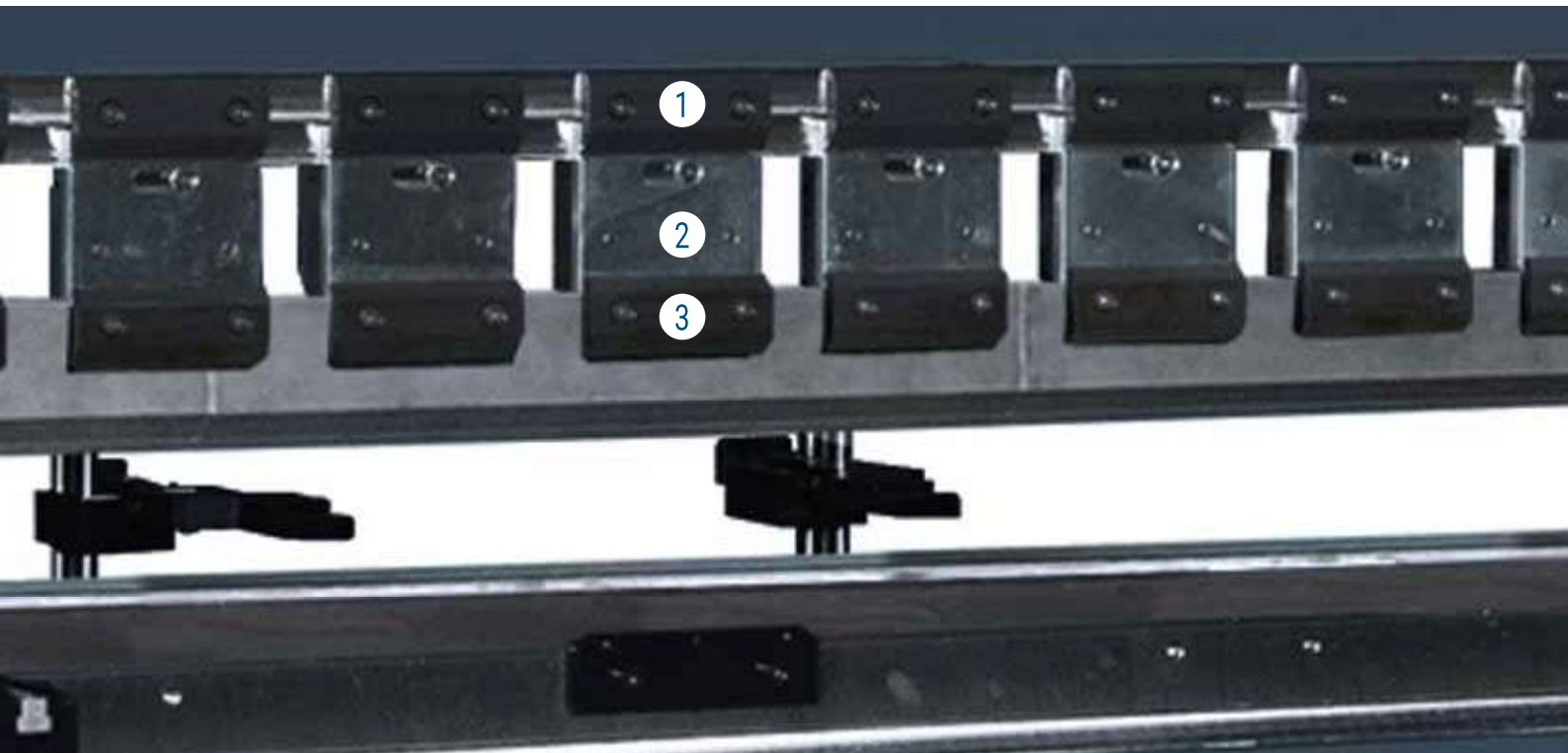

**1** STAFFA SU TAVOLA  
SUPERIORE (fissa)  
TOP BEAM CLAMP (fixed)

**2** INTERMEDIARIO (traslabile a  
destra/sinistra e rimovibile)  
INTERMEDIATE (shiftable right  
or left and removable)

**3** STAFFA SU INTERMEDIARIO  
INTERMEDIATE CLAMP

Il Sistema pneumatico superiore Eurogrip sostituisce alcuni dei componenti standard forniti assieme alla macchina.

In base al modello scelto verranno sostituiti solo gli intermediari (P-EASY) oppure anche la staffa sulla tavola superiore (P-TOP).

L'installazione di un sistema pneumatico richiede una centralina pneumatica e un kit (comprensivo di tubi, connettori, cavi e pulsanti di comando).

*The Eurogrip upper pneumatic clamping systems replaces some of the standard components supplied with the press brake.*

*Depending by the chosen model (P-EASY or P-TOP), only the assembly of intermediate body and its clamp will be replaced, or it will be supplied also a new top beam clamp.*

*The installation of any pneumatic clamping system requires a pneumatic control unit and a pneumatic connection kit (pipes, connectors, cables, switch).*

Modello / Model

**4392**  
(P-EASY Z1)

**SISTEMA PNEUMATICO EUROGRIP P-EASY:**  
STAFFA PNEUMATICA ASSEMBLATA SU INTERMEDIO SPECIFICO Z1

**EUROGRIP PNEUMATIC SYSTEM P-EASY:**  
PNEUMATIC CLAMP ASSEMBLED TO SPECIFIC Z1 STYLE INTERMEDIATE

150 mm 5,2 kg

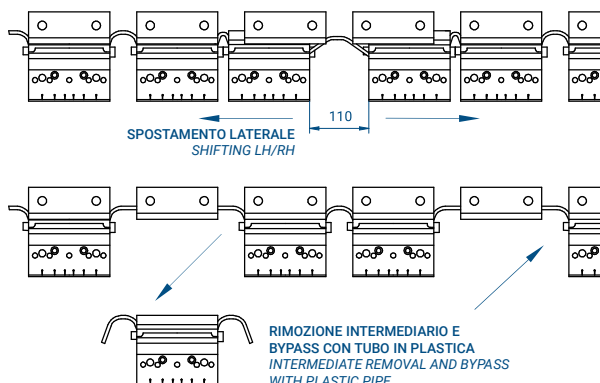
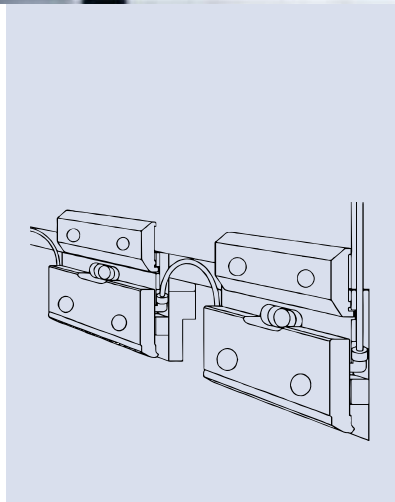
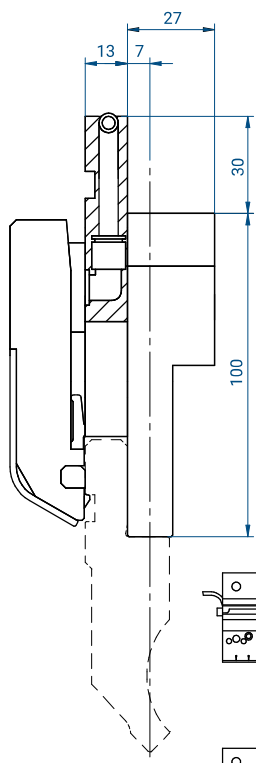

## DESCRIZIONE

Assieme completo costituito da una speciale staffa, ad azionamento pneumatico, installata su un intermedio speciale (Z1) di alta qualità, disegnato per alloggiare la staffa maggiorata (vedere 2 e 3 a pag. 219).

Ciascun nuovo intermedio verrà installato al posto di quello esistente utilizzando le staffe già presenti sulla tavola superiore e verrà collegato in serie agli altri tramite tubo in plastica che ne permette lo spostamento orizzontale e la rimozione (tramite bypass). Soluzione raccomandata quando è necessario spostare/rimuovere gli intermediari raramente.

Il codice 4392 è già predisposto per l'installazione delle staffe manuali posteriori opzionali, codice 4404 (fori passanti).

## SPECIFICHE TECNICHE

Solo su macchine predisposte ad installare intermedi di tipo Z1 (altezza 100mm; corpo 27mm; asse 7mm): tutte le dimensioni dell'intermediario devono essere verificate e confrontate con il disegno tecnico di questa pagina.

Peso= 5,2 Kg

## DESCRIPTION

Full intermediate assembly made up of a special pneumatic clamp already installed over a special, superior quality (Z1), intermediate body conveniently machined for the movement of the operating fingers (see 2 and 3 on page 219).

Each new intermediate will be installed in place of the already existing one by utilizing the top beam clamp already mounted on the top beam and it will be connected in series with the others through a plastic pipe that will allow its horizontal shifting and removal (bypass). This is the recommended solution when the intermediate shifting (or removal) operation is required not more than few times a day.

The intermediate assembly code 4392 is already set for installing the optional rear clamp manually operated, code 4404 (pass-through holes).

## TECHNICAL SPECIFICATIONS

Only on machines equipped for Z1 style intermediates (height 100mm; body width 27mm; bending axis located at 7mm). Please, verify the conformity of the existing intermediate to all of the dimension shown on the drawing.

Weight= 5,2Kg

Modello / Model

**4405**  
(P-EASY Z2)

**SISTEMA PNEUMATICO EUROGRIP P-EASY:**  
STAFFA PNEUMATICA ASSEMBLATA SU INTERMEDIO SPECIFICO Z2

**EUROGRIP PNEUMATIC SYSTEM P-EASY:**  
PNEUMATIC CLAMP ASSEMBLED TO SPECIFIC Z2 STYLE INTERMEDIATE

150 mm 5,2 kg

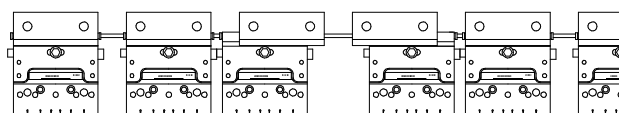
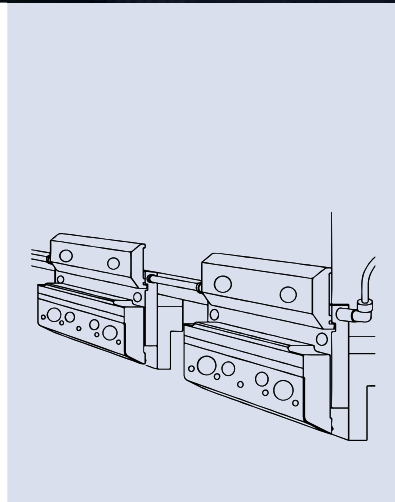
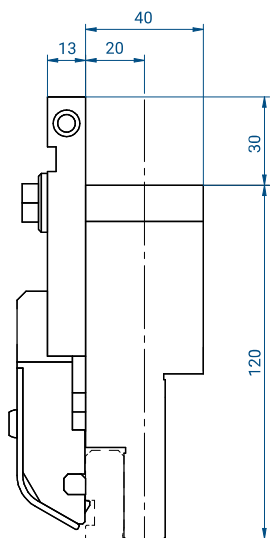

SPOSTAMENTO LATERALE  
SHIFTING LH/RH

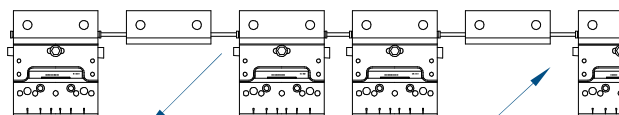

RIMOZIONE INTERMEDIARIO E BYPASS  
CON SPECIFICO TUBO IN ACCIAIO  
INTERMEDIATE REMOVAL AND  
BYPASS WITH SPECIFIC STEEL PIPE

## DESCRIZIONE

Assieme completo costituito da una speciale staffa, ad azionamento pneumatico, installata su un intermedio speciale (Z2) di alta qualità, disegnato per alloggiare la staffa maggiorata (vedere 2 e 3 a pag. 219).

Ciascun nuovo intermedio verrà installato al posto di quello esistente utilizzando le staffe già presenti sulla tavola superiore e verrà collegato in serie agli altri tramite tubo in acciaio che ne permette lo spostamento orizzontale e la rimozione (tramite bypass). Soluzione raccomandata quando è necessario spostare/rimuovere gli intermediari raramente.

Il codice 4405 è già predisposto per l'installazione delle staffe manuali posteriori opzionali, 4404 (fori passanti).

## SPECIFICHE TECNICHE

Solo su macchine predisposte ad installare intermedi di tipo Z2 (altezza 120mm; corpo 40mm; asse 20mm); tutte le dimensioni dell'intermediario devono essere verificate e confrontate con il disegno tecnico di questa pagina.

Peso= 5,9 Kg

## DESCRIPTION

Full intermediate assembly made up of a special pneumatic clamp already installed over a special, superior quality (Z1), intermediate body conveniently machined for the movement of the operating fingers (see 2 and 3 on page 219).

Each new intermediate will be installed in place of the already existing one by utilizing the top beam clamp already mounted on the top beam and it will be connected in series with the others through a steel pipe that will allow its horizontal shifting and removal (bypass). This is the recommended solution when the intermediate shifting (or removal) operation is not required more than few times a day.

The intermediate assembly code 4405 is already set for installing the optional rear clamp manually operated, code 4404 (pass-through holes).

## TECHNICAL SPECIFICATIONS

Only on machines equipped for Z2 style intermediates (height 120mm; body width 40mm; bending axis located at 7mm). Please, verify the conformity of the existing intermediate to all of the dimension shown on the drawing.

Weight= 5,9Kg

Modello / Model

## 4399

(P-TOP common)

**SISTEMA PNEUMATICO EUROGRIP P-TOP: STAFFA PNEUMATICA PER TAVOLA SUPERIORE – PREREQUISITO PER INSTALLAZIONE DI MODELLI P-TOP**

**EUROGRIP PNEUMATIC SYSTEM P-TOP: PNEUMATIC CLAMP TO BE INSTALLED ON THE MACHINE UPPER TABLE – MANDATORY FOR THE INSTALLATION OF ANY P-TOP MODEL**

150 mm 1,0 kg



### DESCRIZIONE

Staffa per tavola superiore da installare al posto di quella montata in origine (vedere 1 a pag. 219).

Ogni staffa è collegata in serie tramite tubo in acciaio e trasferisce l'aria in pressione all'intermediario connesso attraverso una valvola interna che ne consente lo spostamento e la rimozione senza necessità di operazioni aggiuntive (bypass).

Soluzione raccomandata quando è necessario spostare (o rimuovere) gli intermediari con frequenza elevata.

### DESCRIPTION

It must replace the actual standard clamps installed on the machine top beam (see 1 on page 219).

Each new top beam clamp is connected in series through a steel pipe and transfers the air flow to the connected intermediate by an internal valve that allows to shift the intermediate left or right and even to remove it without the need of any bypass.

This is the recommended solution when the intermediate shifting (or removal) operation must be performed many times a day.

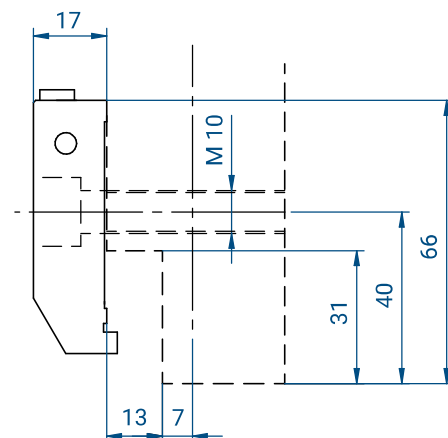
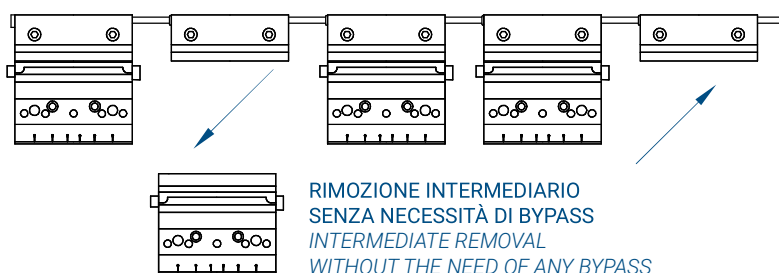
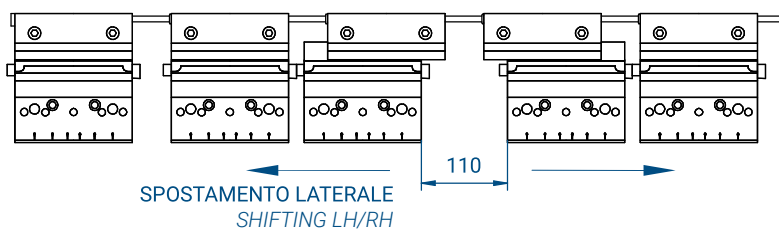
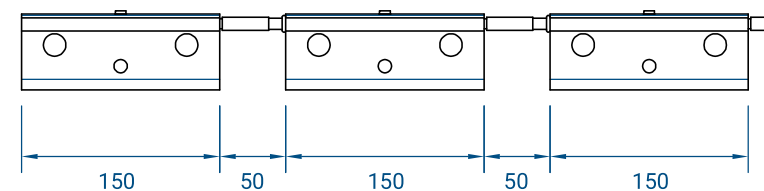

Modello / Model

**4398**  
(P-TOP Z1)

150 mm 5,2 kg

**SISTEMA PNEUMATICO EUROGRIP P-TOP: STAFFA PNEUMATICA ASSEMBLATA SU INTERMEDIO SPECIFICO Z1 - RICHIEDE INSTALLAZIONE DI STAFFA PER TAVOLA SUPERIORE 4399**

**EUROGRIP PNEUMATIC SYSTEM P-TOP: PNEUMATIC CLAMP ASSEMBLED TO SPECIFIC Z1 STYLE INTERMEDIATE - IT IS MANDATORY TO INSTALL THE UPPER BEAM CLAMP 4399**

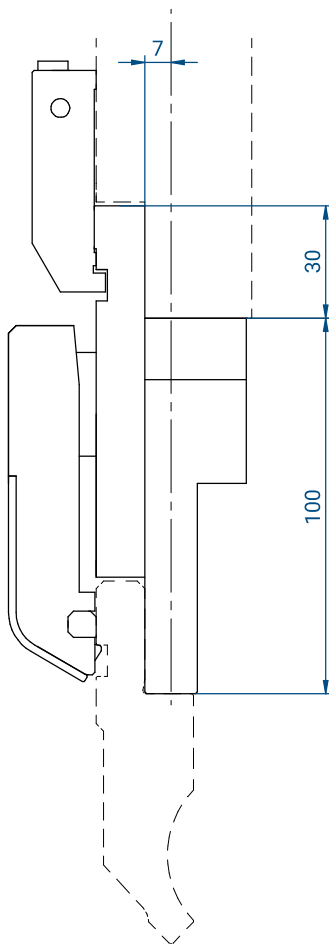
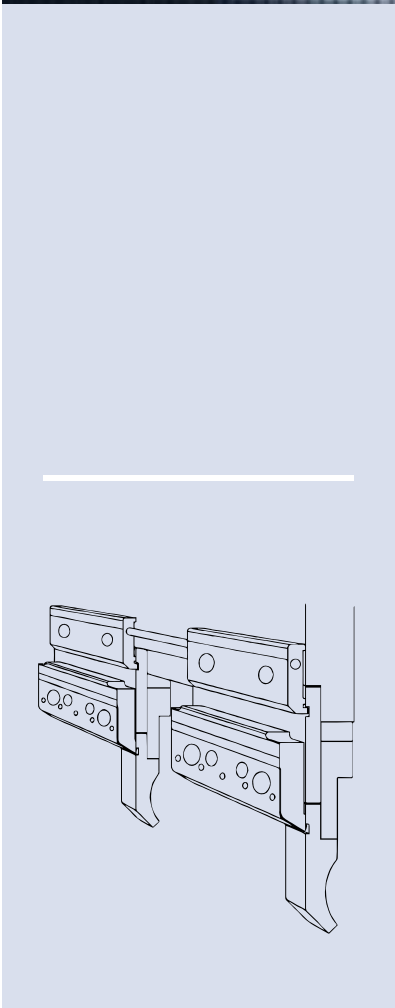

**DESCRIZIONE**

Assieme completo costituito da una speciale staffa, ad azionamento pneumatico, installata su un intermedio speciale (Z1) di alta qualità, disegnato per alloggiare la staffa maggiorata (vedere 2 e 3 a pag. 219).

Ciascun nuovo intermedio verrà installato utilizzando le staffe 4399 che ne gestiranno l'alimentazione di aria compressa.

L'assieme intermedio 4391 è già predisposto per l'installazione delle staffe manuali posteriori opzionali, codice 4404 (fori passanti).

**SPECIFICHE TECNICHE**

Solo su macchine predisposte ad installare intermedi di tipo Z1 (altezza 100mm; corpo 27mm; asse 7mm): tutte le dimensioni dell'intermedio devono essere verificate e confrontate con il disegno tecnico di questa pagina.

Peso= 6,2 Kg

Il codice 4398 identifica l'assieme intermedio + staffa superiore (4391+ 4399).

**DESCRIPTION**

Full intermediate assembly made up of a special pneumatic clamp already installed over a special, superior quality (Z1), intermediate body conveniently machined for the movement of the operating fingers (see 2 and 3 on page 219).

Each new intermediate will be installed in place of the already existing one by utilizing the 4399 top beam clamp that will manage the pneumatic supply.

The intermediate assembly code 4391 is already set for installing the optional rear clamp manually operated, code 4404 (pass-through holes).

**TECHNICAL SPECIFICATIONS**

Only on machines equipped for Z1 style intermediates (height 100mm; body width 27mm; bending axis located at 7mm). Please, verify the conformity of the existing intermediate to all of the dimension shown on the drawing.

Weight= 6,2Kg

The code 4398 identifies the assembly of intermediate + top beam clamp (4391+4399).

Modello / Model

**4410**  
(P-TOP Z2)

150 mm 5,2 kg

**SISTEMA PNEUMATICO EUROGRIP P-TOP: STAFFA PNEUMATICA ASSEMBLATA SU INTERMEDIO SPECIFICO Z2 RICHIEDE INSTALLAZIONE DI STAFFA PER TAVOLA SUPERIORE 4399**

**EUROGRIP PNEUMATIC SYSTEM P-TOP: PNEUMATIC CLAMP ASSEMBLED TO SPECIFIC Z2 STYLE INTERMEDIATE IT IS MANDATORY TO INSTALL THE UPPER BEAM CLAMP 4399**

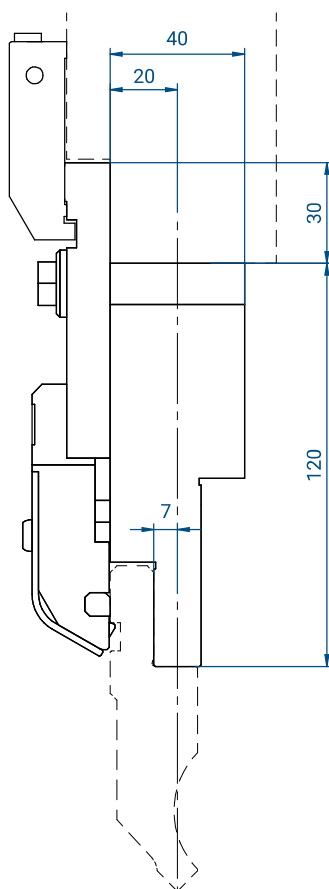
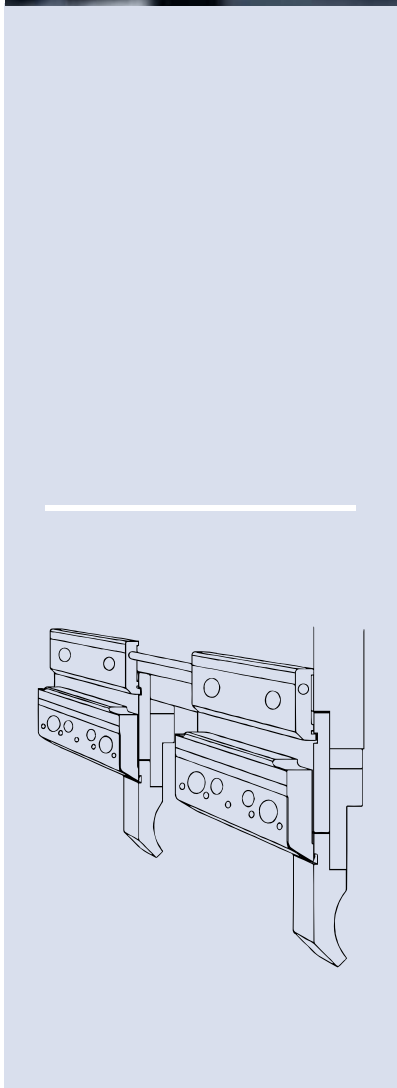

**DESCRIZIONE**

Assieme completo costituito da una speciale staffa, ad azionamento pneumatico, installata su un intermedio speciale (Z2) di alta qualità, disegnato per alloggiare la staffa maggiorata (vedere 2 e 3 a pag. 219).

Ciascun nuovo intermedio verrà installato utilizzando le staffe 4399 che ne gestiranno l'alimentazione di aria compressa.

L'assieme intermedio 4410 è già predisposto per l'installazione delle staffe manuali posteriori opzionali, codice 4404 (fori passanti).

**SPECIFICHE TECNICHE**

Solo su macchine predisposte ad installare intermedi di tipo Z2 (altezza 120mm; corpo 40mm; asse 20mm); tutte le dimensioni dell'intermedio devono essere verificate e confrontate con il disegno tecnico di questa pagina.

Peso= 6,2 Kg

Il codice 4412 identifica l'assieme intermedio + staffa superiore (4410+ 4399).

**DESCRIPTION**

Full intermediate assembly made up of a special pneumatic clamp already installed over a special, superior quality (Z2), intermediate body conveniently machined for the movement of the operating fingers (see 2 and 3 on page 219).

Each new intermediate will be installed in place of the already existing one by utilizing the 4399 top beam clamp that will manage the pneumatic supply.

The intermediate assembly code 4410 is already set for installing the optional rear clamp manually operated, code 4404 (pass-through holes).

**TECHNICAL SPECIFICATIONS**

Only on machines equipped for Z2 style intermediates (height 120mm; body width 40mm; bending axis located at 20mm). Please, verify the conformity of the existing intermediate to all of the dimension shown on the drawing.

Weight= 6,2Kg

The code 4412 identifies the assembly of intermediate + top beam clamp (4410+4399).

Modello / Model

## 4394 (P-HOLD)

835 mm	27,8 kg
625 mm	20,8 kg
415 mm	13,8 kg



**SISTEMA PNEUMATICO INFERIORE EUROGRIP P-DHOLD: SUPPORTO AD AZIONAMENTO PNEUMATICO PER MATRICI STILE AMADA**

**EUROGRIP LOWER PNEUMATIC SYSTEM P-DHOLD: PNEUMATIC DIE HOLDER FOR AMADA STYLE DIES**

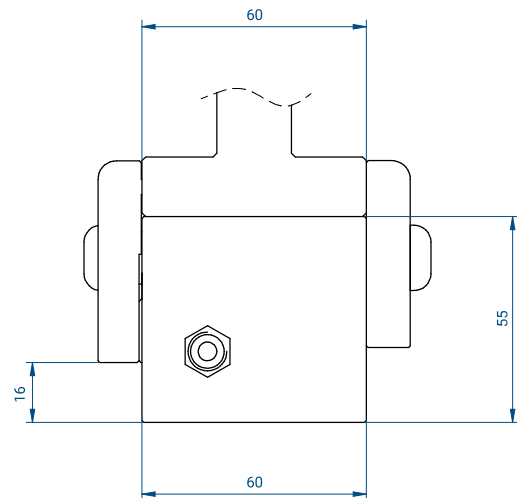

### DESCRIZIONE

Supporto matrici modulare in stile Europeo (Stile Amada/Promecam). Sul lato frontale monta una serie di staffe ad azionamento pneumatico. Ogni modulo si connette al successivo tramite un connettore a scomparsa. Sistema raccomandato per clienti che devono sostituire frequentemente gli utensili inferiori perché consente il blocco/sblocco simultaneo di tutti gli utensili inferiori con la sola pressione di un pulsante.

### SPECIFICHE TECNICHE

Installabile su macchine con tavola inferiore piana conforme allo standard stile Europeo (stile Amada /Promecam). Disponibile in moduli con lunghezza 835mm; 415mm; 625mm.

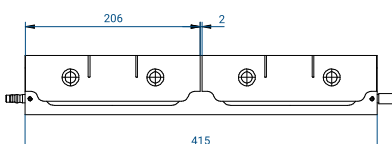
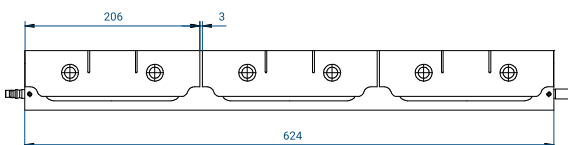
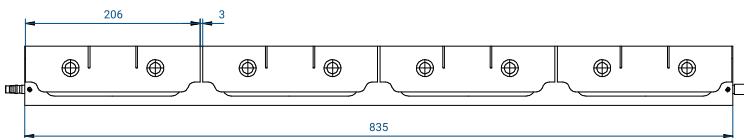
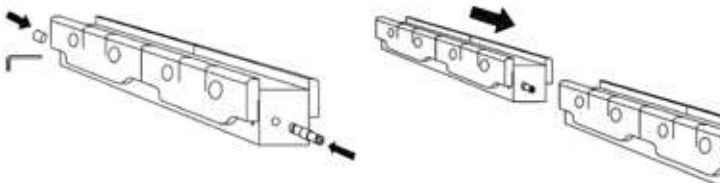

### DESCRIPTION

Modular lower die support based on the standard European style (Amada/Promecam style) that carry on its front side a series of pneumatic clamps. Each module connects to the next one through a foldaway connector. This solution is recommended to those customers used to replace frequently the lower tooling because it allows to clamp/unclamp the whole lower table by simply operate a button.

### TECHNICAL SPECIFICATIONS

Can be installed on any machine equipped with a lower flat table that conforms to the European style (Amada/Promecam style). Available in modules long 835mm; 415mm; 625mm.

Per gestire i sistemi pneumatici Eurogrip è necessario installare una unità di controllo pneumatica, che contiene la componentistica elettrica e pneumatica per pilotare il sistema, oltre ad un kit, specifico per il modello ordinato, che comprende i tubi, i cavi ed i connettori da utilizzare per installare correttamente il sistema.

*In order to manage correctly any Eurogrip pneumatic system it is required to install a pneumatic control unit, that contains the electric and pneumatic system components necessary for driving the system, and to utilize a hardware kit, specific for the ordered system, that includes the supply of the pipes, cables and connectors required for the correct installation of the system.*

Modello / Model

### 4395 (single line)

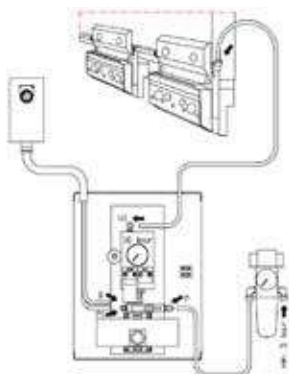

SISTEMA PNEUMATICO EUROGRIP:  
CENTRALINA PNEUMATICA LINEA  
SINGOLA, COMPENSIVA DI  
ACCESSORI

*EUROGRIP PNEUMATIC SYSTEM:  
PNEUMATIC CONTROL UNIT SINGLE  
LINE, ACCESSORIES INCLUDED*

DESCRIZIONE

Si connette alla sorgente di aria compressa disponibile in officina (pressione minima ingresso 6 Bar). Gestisce la pressione in uscita verso il sistema di connessione tramite una sola uscita per pilotare solamente un sistema di connessione (superiore o inferiore). Contiene i circuiti di controllo e di sicurezza.

DESCRIPTION

*It connects to the job shop pressurized air supply (minimum input pressure 6 Bar).*

*It manages the output pressure to the clamping system through only one output connector (only upper or only lower).*

*It contains all of the electrical connections and the safety system.*

DESCRIZIONE

Si connette alla sorgente di aria compressa disponibile in officina (pressione minima ingresso 6 Bar). Gestisce la pressione in uscita verso il sistema di connessione tramite due sole uscite per pilotare entrambi i sistemi di connessione (superiore e inferiore). Contiene i circuiti di controllo e di sicurezza.

DESCRIPTION

*It connects to the job shop pressurized air supply (minimum input pressure 6 Bar). It manages the output pressure to the clamping system through two output connector (upper and lower).*

*It contains all of the electrical connections and the safety system.*

Modello / Model

### 4396 (two lines)

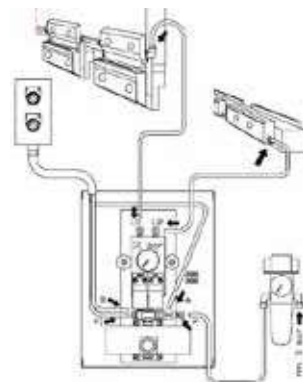

SISTEMA PNEUMATICO EUROGRIP: CENTRALINA PNEUMATICA LINEA DOPPIA, COMPENSIVA DI ACCESSORI

*EUROGRIP PNEUMATIC SYSTEM:  
PNEUMATIC CONTROL UNIT  
DOUBLE LINE, ACCESSORIES  
INCLUDED*

Modello / Model

### 4397 (KIT P-EASY)

SISTEMA PNEUMATICO EUROGRIP:  
KIT CONNESSIONI P-EASY

*EUROGRIP PNEUMATIC SYSTEM:  
P-EASY CONNECTION KIT*

DESCRIZIONE

Assieme dei componenti necessari per installare e collegare il sistema P-EASY.

DESCRIPTION

*Assembly of hardware required for installing and connecting the P-EASY system.*

Modello / Model

### 4381 (KIT P-TOP)

SISTEMA PNEUMATICO EUROGRIP:  
KIT CONNESSIONI P-TOP

*EUROGRIP PNEUMATIC SYSTEM:  
P-TOP CONNECTION KIT*

DESCRIZIONE

Assieme dei componenti necessari per installare e collegare il sistema P-TOP.

DESCRIPTION

*Hardware kit required for installing and connecting the P-TOP system.*

## INTERMEDIARI REGISTRABILI ADJUSTABLE INTERMEDIATES

GLI INTERMEDIARI REGISTRABILI (COMPLETI CON CUNEO PER CENTINATURA) POTREBBERO ESSERE FORNITI IN VERSIONE MONOLITICA OPPURE ASSEMBLATA (CORPO INTERMEDIARIO + PIASTRA FRONTALE)

THE ADJUSTABLE INTERMEDIATES (ASSEMBLED WITH THE ADJUSTABLE WEDGE) COULD BE SUPPLIED IN MONOLITHIC VERSION OS IN THE ASSEMBLED VERSION (INTERMEDIATE BODY + FRONT PLATE)

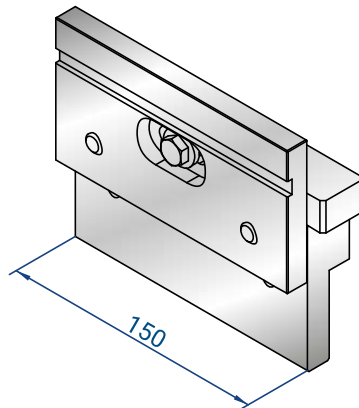
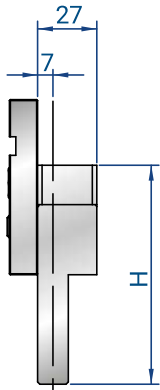

### 4221

H = 100

150 mm 3,6 kg

### 4222

H = 120

150 mm 4,6 kg

### 4223

H = 150

150 mm 6,0 kg

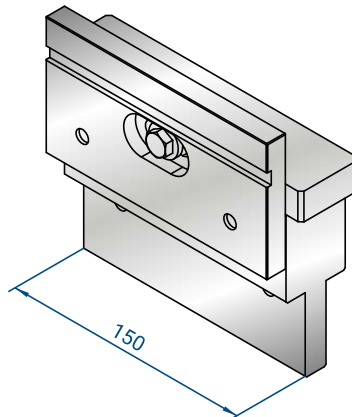
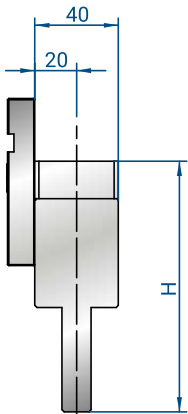

### 4224

H = 100

150 mm 4,2 kg

COMPATIBILE CON  
STAFFA 5011, 5012

COMPATIBLE WITH  
CLAMP 5011, 5012

### 4225

H = 120

150 mm 5,3 kg

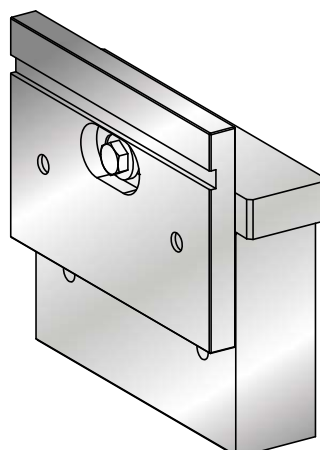
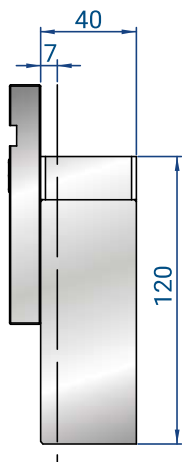

### 4073 - HD

H = 120

150 mm 7,2 kg

PER ALTI  
TONNELLAGGI

HEAVY DUTY

INTERMEDIARI REGISTRABILI  
ADJUSTABLE INTERMEDIATES

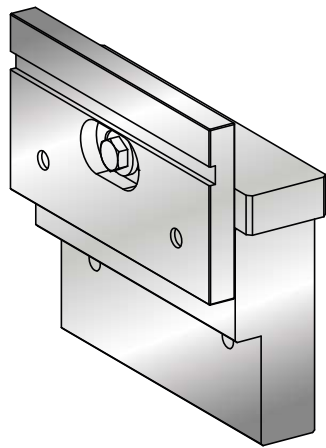
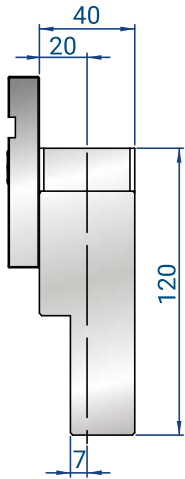

**4411-HD**

H = 120

150 mm 6,1 kg

PER ALTI  
TONNELLAGGI  
HEAVY DUTY

INTERMEDIARI FISSI / FIXED INTERMEDIATES

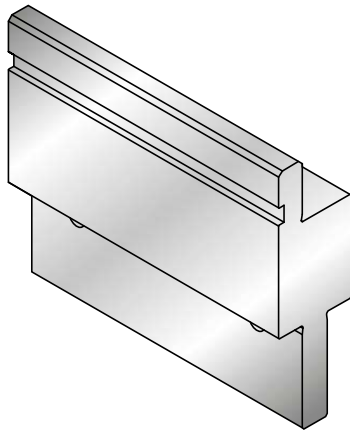
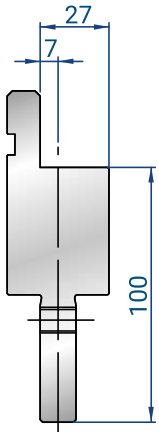

**4282**

H = 100

150 mm 3,8 kg

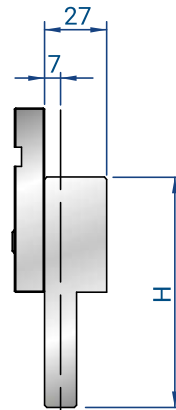

**4226**

H = 100

75 mm 1,8 kg

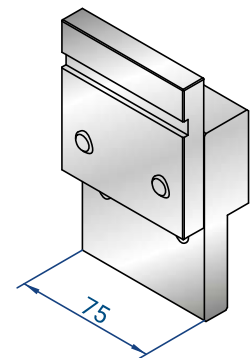

**4227**

H = 150

75 mm 2,9 kg

**4228**

H = 120

75 mm 2,6 kg

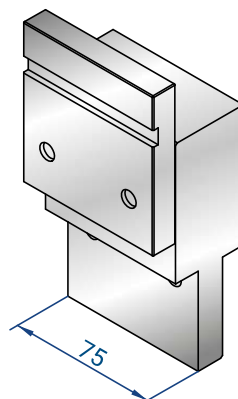
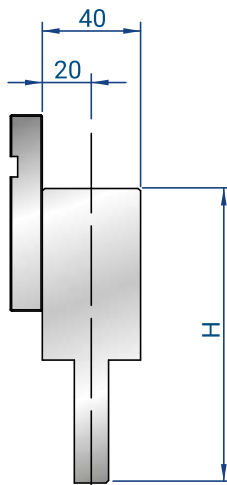

LE VITI STANDARD M10X35 VERRANNO INCLUSE SOLO PER ORDINI RELATIVI AD ASSIEME INTERMEDIO PIÙ STAFFA

THE STANDARD SCREWS M10X35 WILL BE INCLUDED ONLY FOR ORDERS RELATED TO INTERMEDIATE PLUS CLAMP ASSEMBLIES

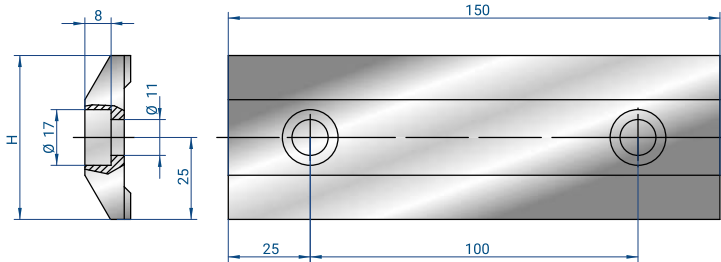

DA INSTALLARE UTILIZZANDO VITI STANDARD M10X35  
TO BE INSTALLED WITH STANDARD SCREWS M10X35

**4016**

H = 50

150 mm 0,6 kg

**5013**

H = 43

150 mm 0,6 kg

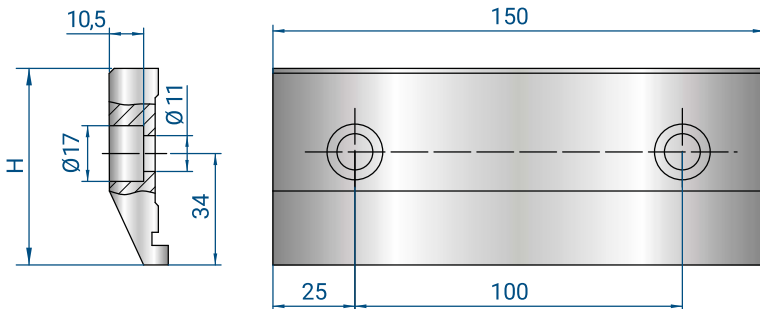

DA INSTALLARE UTILIZZANDO VITI STANDARD M10X35  
TO BE INSTALLED WITH STANDARD SCREWS M10X35

**4020**

H = 60

150 mm 0,8 kg

✗ #4000; #4224

**5012**

H = 52

150 mm 0,7 kg

✓ #4000; #4224



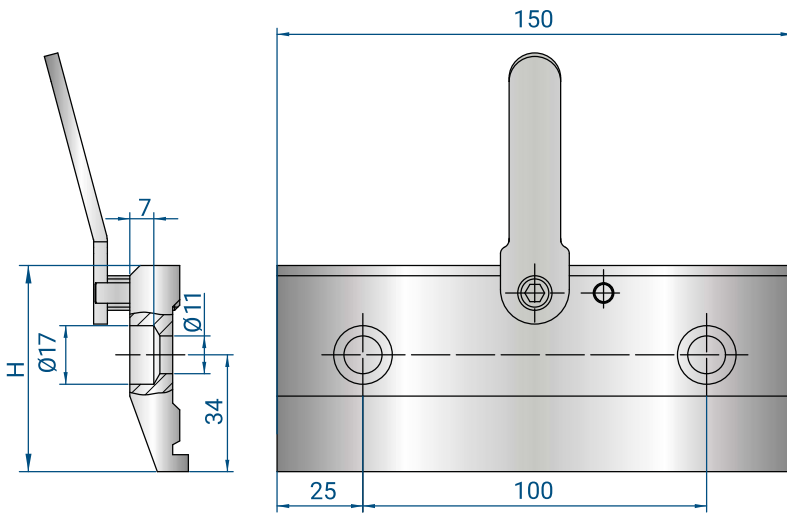

**4021**

H = 60

150 mm 0,9 kg

✘ #4000; #4224

**5011**

H = 52

150 mm 0,8 kg

✔ #4000; #4224

DA INSTALLARE UTILIZZANDO LE VITI SPECIALI 4281 (IN DOTAZIONE)

TO BE INSTALLED WITH SPECIAL SCREWS 4281 (SUPPLIED WITH THE CLAMP)

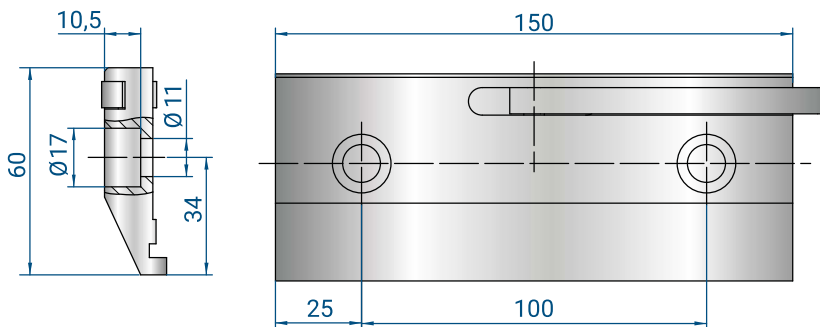

**4009**

H = 60

150 mm 0,9 kg

✘ #4000; #4001; #4224

DA INSTALLARE UTILIZZANDO VITI STANDARD M10X35

TO BE INSTALLED WITH STANDARD SCREWS M10X35

LE VITI STANDARD M10X35 VERRANNO INCLUSE SOLO PER ORDINI RELATIVI AD ASSIEME INTERMEDIO PIÙ STAFFA

THE STANDARD SCREWS M10X35 WILL BE INCLUDED ONLY FOR ORDERS RELATED TO INTERMEDIATE PLUS CLAMP ASSEMBLIES

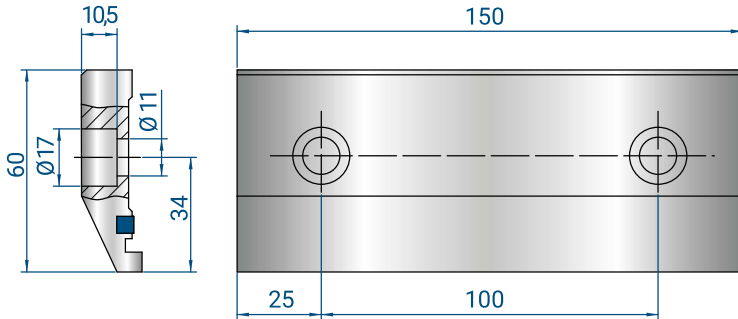

**4199**

H = 60

150 mm 0,8 kg

DA INSTALLARE  
UTILIZZANDO VITI  
STANDARD M10X35

TO BE INSTALLED WITH  
STANDARD SCREWS  
M10X35

✕ #4000; #4001; #4224

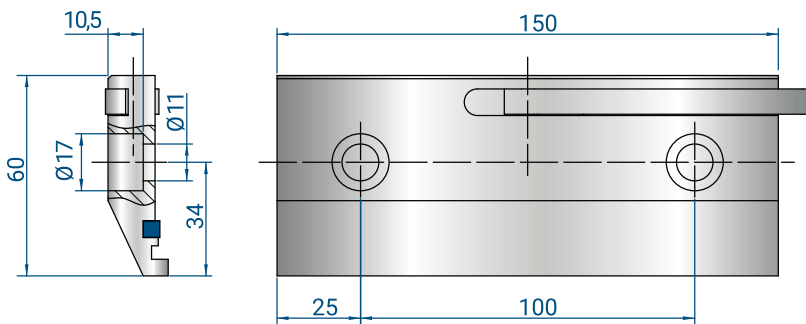

**4220**

H = 60

150 mm 0,8 kg

DA INSTALLARE  
UTILIZZANDO VITI  
STANDARD M10X35

TO BE INSTALLED WITH  
STANDARD SCREWS  
M10X35

✕ #4000; #4001; #4224

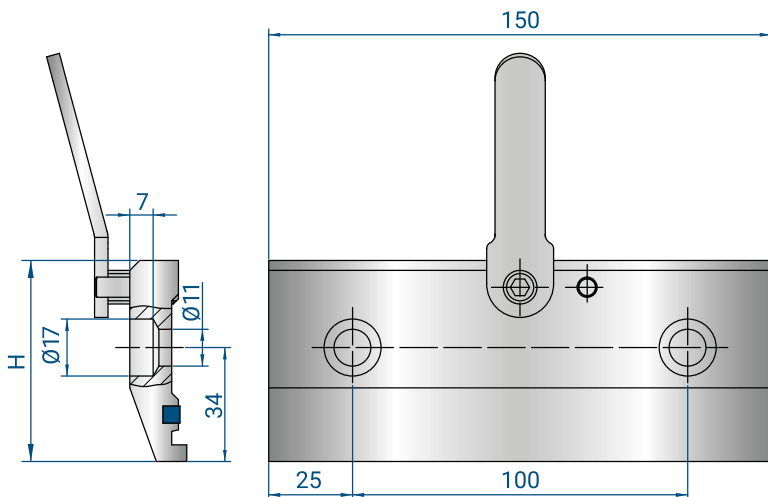

**4219**

H = 60

150 mm 0,9 kg

DA INSTALLARE  
UTILIZZANDO LE VITI  
SPECIALI 4281 (IN  
DOTAZIONE)

TO BE INSTALLED WITH  
SPECIAL SCREWS 4281  
(SUPPLIED WITH THE  
CLAMP)

✕ #4000; #4224

**4349**



LISTELLO IN POLIURETANO,  
RICAMBIO PER STAFFA:

POLYURETHANE STRIP,  
SPARE PART FOR:

#4199; #4220; #4219

**4281**

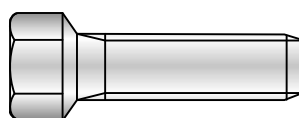

VITI SPECIALI PER  
STAFFE 4021-5011-  
4219-4007, FORNITE  
CON STAFFA

SPECIAL SCREWS FOR  
CLAMPS 4021-5011-  
4219-4007, SUPPLIED  
WITH CLAMP

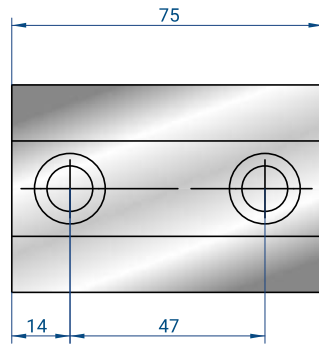
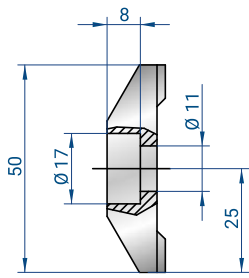

**4008**

DA INSTALLARE  
UTILIZZANDO VITI  
STANDARD M10X35

H = 50

TO BE INSTALLED WITH  
STANDARD SCREWS  
M10X35

75 mm	0,3 kg
-------	--------

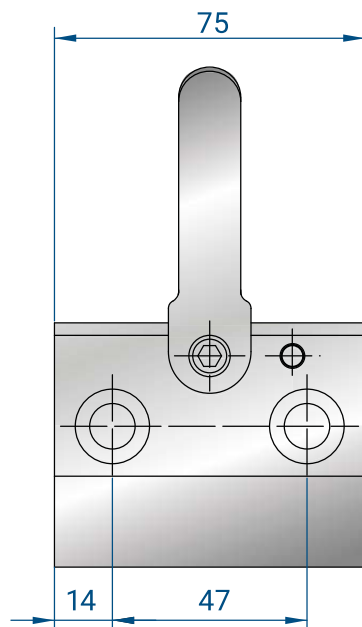
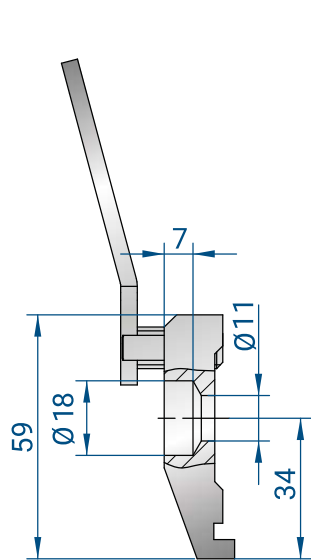

**4007**

DA INSTALLARE  
UTILIZZANDO LE VITI  
SPECIALI 4281

H = 59

TO BE INSTALLED WITH  
SPECIAL SCREWS 4281

75 mm	0,5 kg
-------	--------

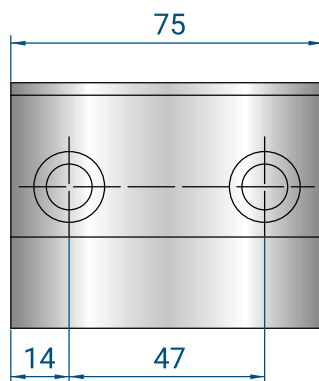
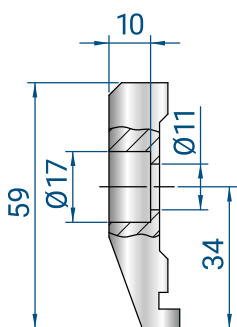

**4090**

DA INSTALLARE  
UTILIZZANDO VITI  
STANDARD M10X35

H = 59

TO BE INSTALLED WITH  
STANDARD SCREWS  
M10X35

75 mm	0,4 kg
-------	--------

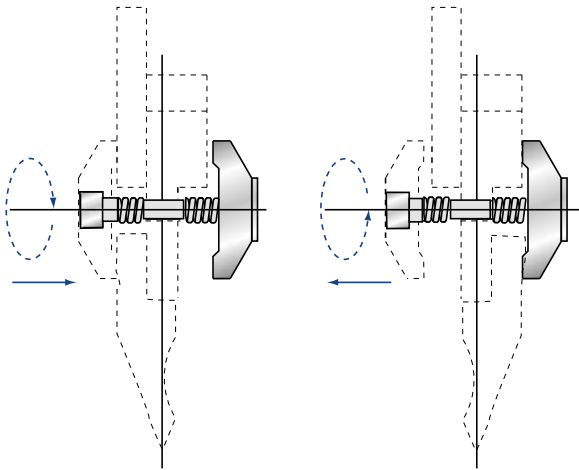
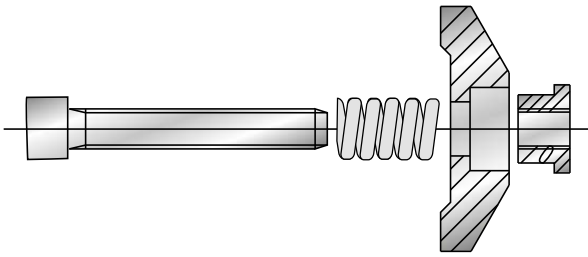

## 4031

KIT PER DOPPIO STAFFAGGIO  
EQUIPMENT FOR DOUBLE CLAMPING

150 mm	1,0 kg
--------	--------

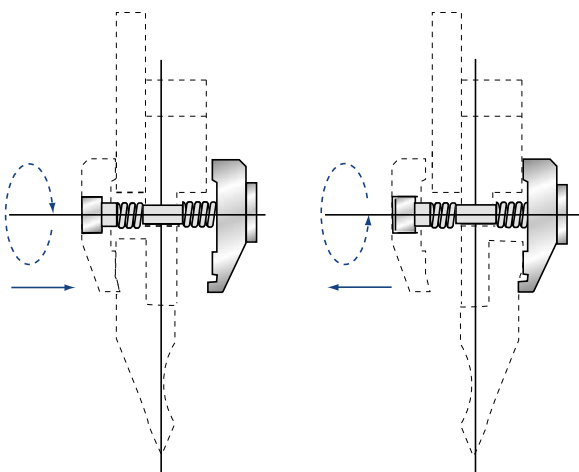
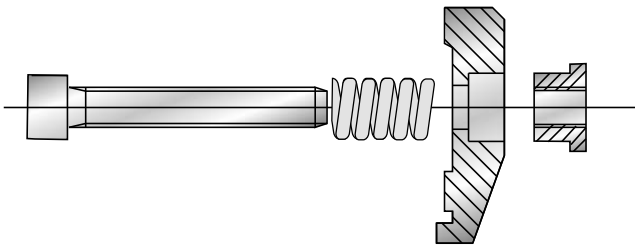

## 4032

KIT PER DOPPIO STAFFAGGIO  
EQUIPMENT FOR DOUBLE CLAMPING

150 mm	1,2 kg
--------	--------

ADATTATORI GENERICI PER UTENSILI SUPERIORI AMADA/PROMECAM STYLE  
 GENERIC UPPER ADAPTERS FOR AMADA/PROMECAM STYLE TOOLING

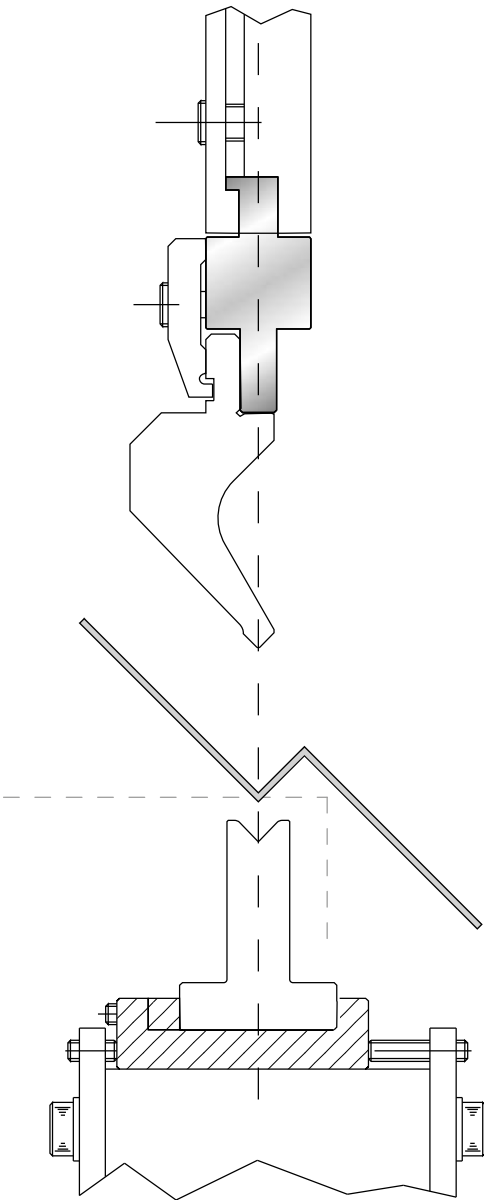

ORDINE MINIMO N. 5 ADATTATORI  
 MINIMUM ORDER N. 5 ADAPTERS

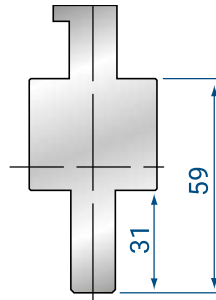

**4000**

150 mm 1,5 kg

STAFFA / CLAMP

**5011; 5012**

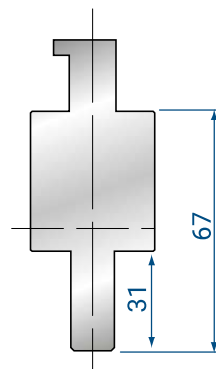

**4001**

150 mm 2,0 kg

STAFFA / CLAMP

Max H = 60mm

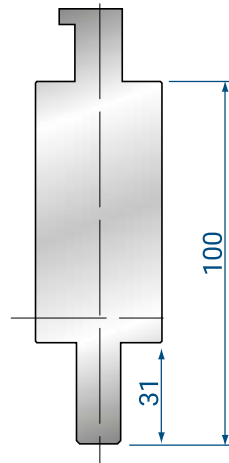

**4002**

150 mm 3,5 kg

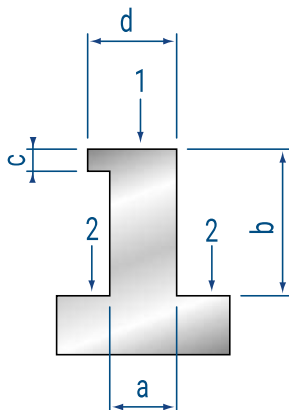

	1	2
<b>a =</b>		
<b>b =</b>		
<b>c =</b>		
<b>d =</b>		

INDICARE QUOTE D'ATTACCO  
 E PUNTI DI SPINTA (1,2)

PLEASE MARK CONTACT POINTS  
 AND PRESSURE POINTS (1,2)

ADATTORI SPECIFICI PER UTENSILI SUPERIORI AMADA/PROMECAM  
 SPECIFIC UPPER ADAPTERS FOR AMADA/PROMECAM STYLE TOOLING

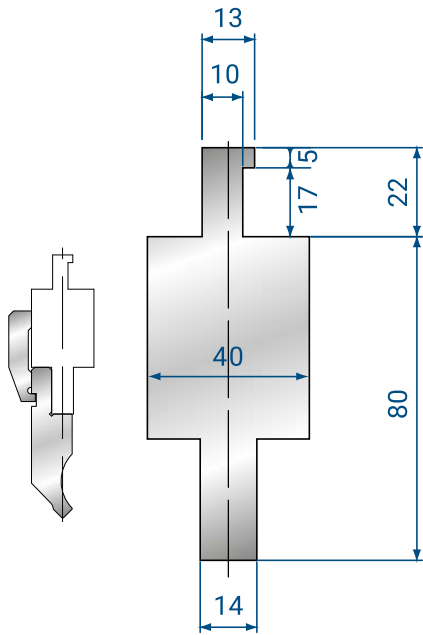

**4143**

LVD STYLE S  
 (small)  
 STANDARD

150 mm 3,0 kg

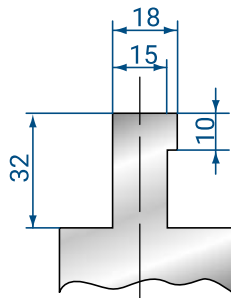

**4144**

LVD STYLE M  
 (medium)  
 SPECIAL

150 mm 3,0 kg

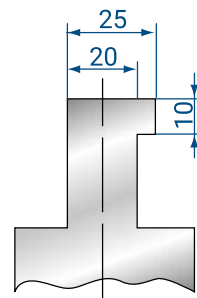

**4145**

LVD STYLE L  
 (large)  
 SPECIAL

150 mm 3,0 kg

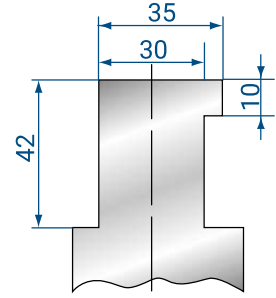

**4146**

LVD STYLE XL  
 (Extra Large)  
 SPECIAL

150 mm 3,0 kg

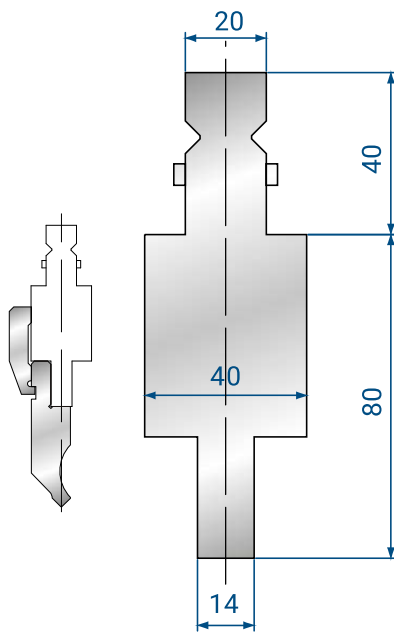

**4191**

TRUMPF/WILA  
 STYLE

150 mm 3,6 kg

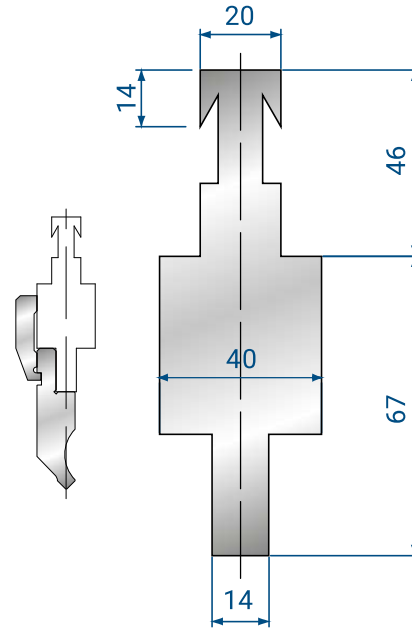

**4192**

BYSTRONIC-R  
 STYLE

150 mm 3,0 kg

ADATTORI SPECIFICI PER UTENSILI SUPERIORI AMADA/PROMECAM  
 SPECIFIC UPPER ADAPTERS FOR AMADA/PROMECAM STYLE TOOLING

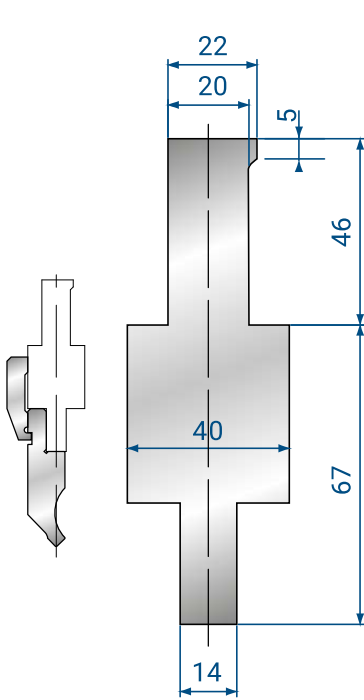

**4193**

BYSTRONIC - S  
 STYLE

150 mm 3,2 kg

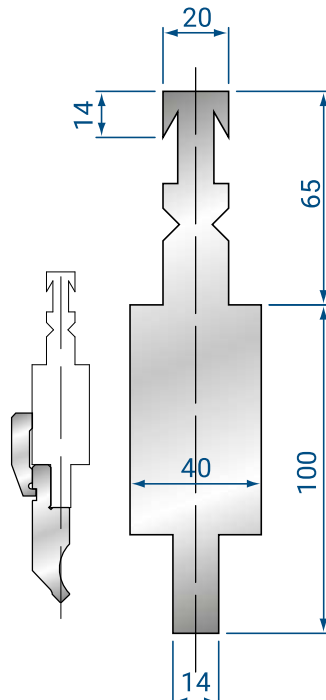

**4214**

BYSTRONIC -  
 RF-A STYLE

150 mm 5,0 kg

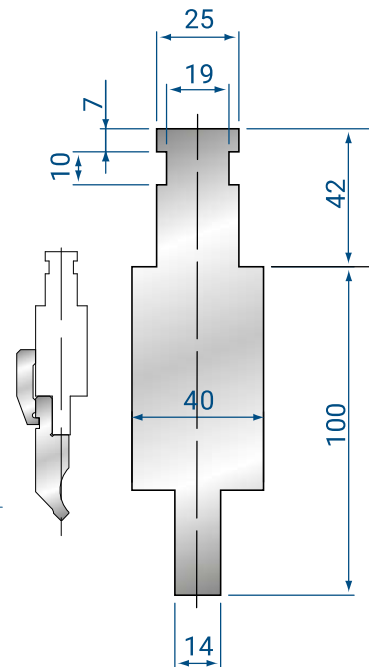

**4215**

WEINBRENNER  
 STYLE

150 mm 4,8 kg

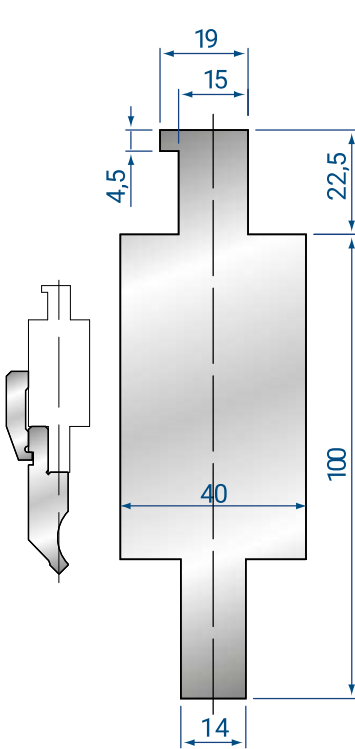

**4216**

CBC STYLE

150 mm 4,1 kg

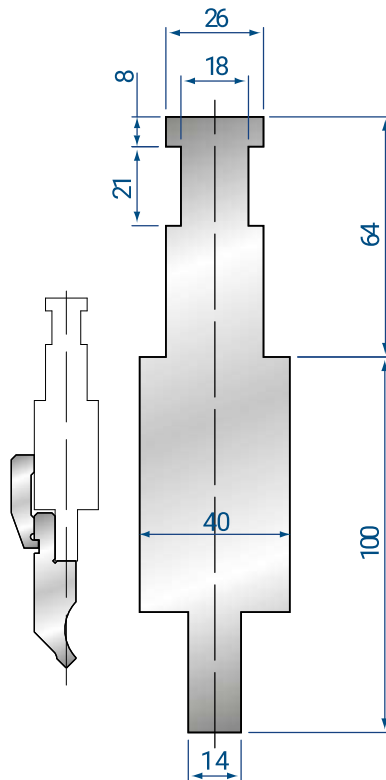

**4217**

EHT STYLE

150 mm 5,4 kg

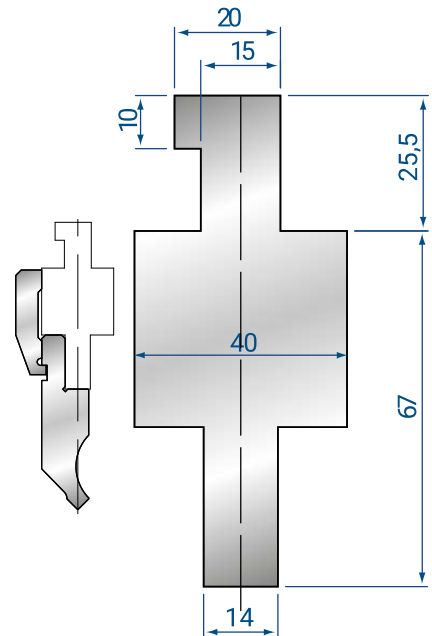

**4218**

DURMAZLAR  
 STYLE

150 mm 2,6 kg

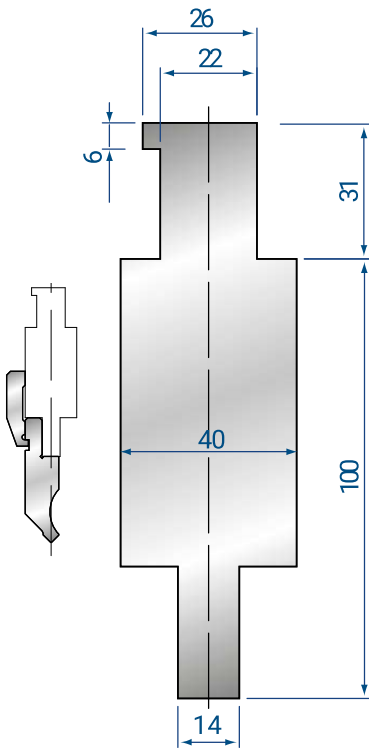

**4229**

DARLEY STYLE

150 mm 4,5 kg

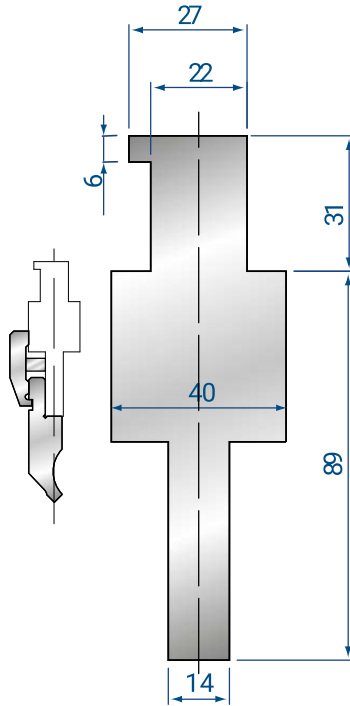

**4272**

BAYKAL STYLE

150 mm 3,5 kg

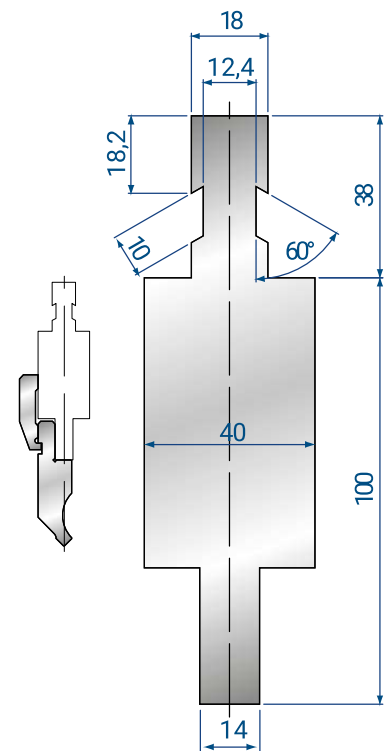

**4273**

COLGAR STYLE

150 mm 4,4 kg

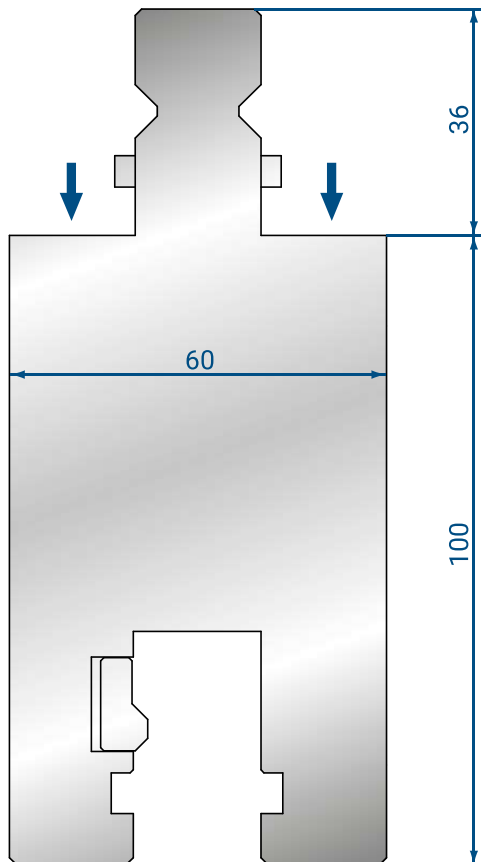

**4361**

PROLUNGA / EXTENTION FOR TRUMPF / WILA STYLE

H = 100

150 mm 7,0 kg

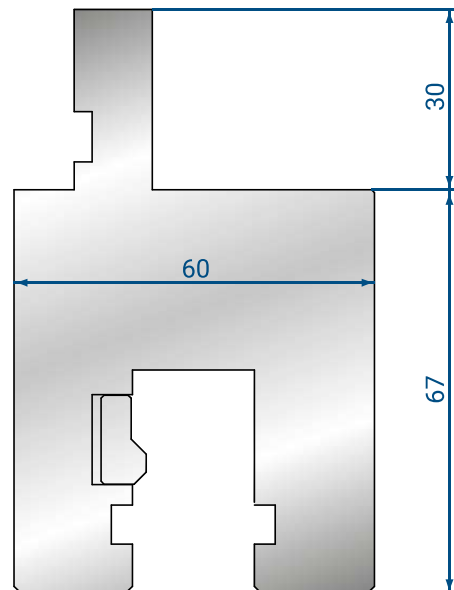

**4362**

ADATTATORE / ADAPTER FROM AMADA STYLE TO TRUMPF / WILA STYLE

H = 67

150 mm 4,0 kg

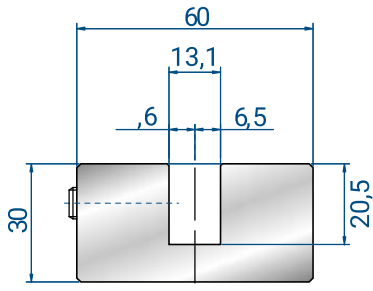

### 4301

FROM AMADA STYLE  
TO TRUMPF - WILA -  
BYSTRONIC STYLE

1000 mm	11,9 kg
500 mm	6,0 kg

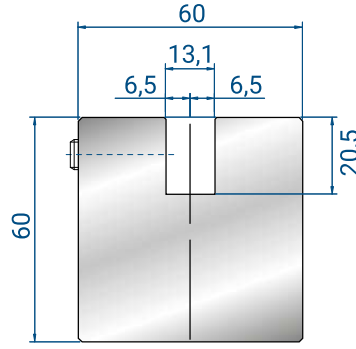
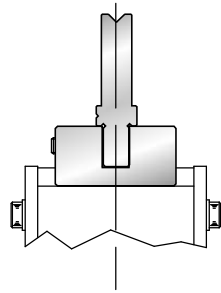

### 4302

FROM AMADA STYLE  
TO TRUMPF - WILA -  
BYSTRONIC STYLE

1000 mm	26,0 kg
500 mm	13,0 kg

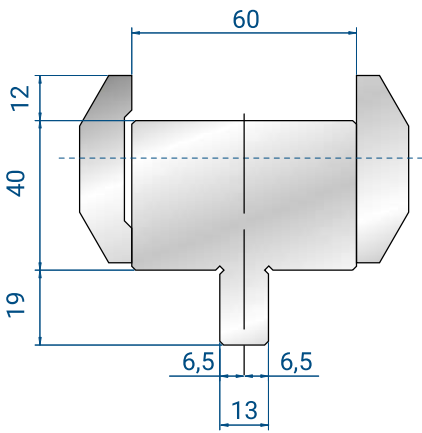
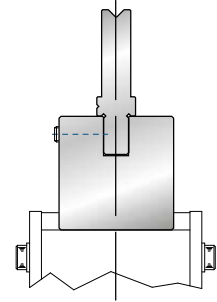

### 4303

FROM TRUMPF - WILA - BYSTRONIC  
STYLE TO AMADA STYLE

835 mm	21,3 kg
415 mm	11,2 kg

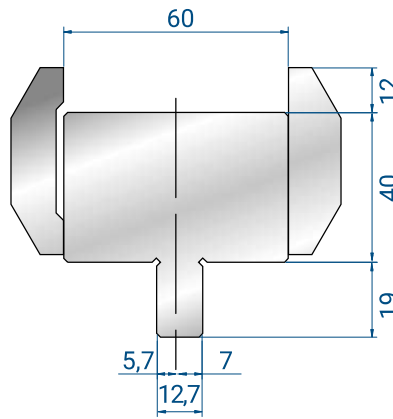
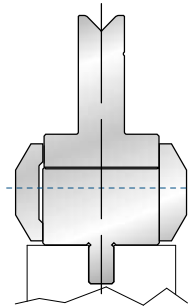

### 4304

FROM LVD STYLE TO  
AMADA STYLE

835 mm	21,3 kg
415 mm	11,2 kg

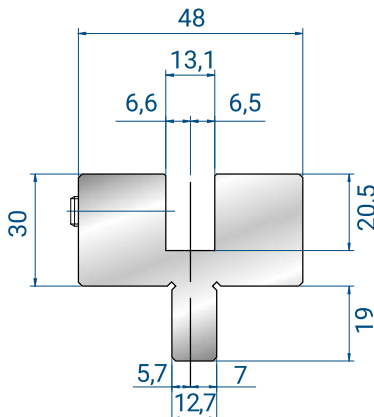
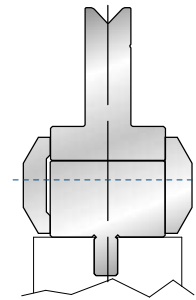

### 4305

FROM LVD STYLE TO TRUMPF -  
WILA - BYSTRONIC STYLE

1000 mm	11,0 kg
500 mm	11,0 kg

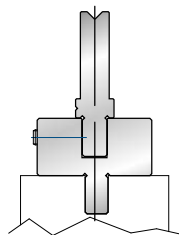

**4033**

835 mm	25,5 kg
415 mm	13,3 kg

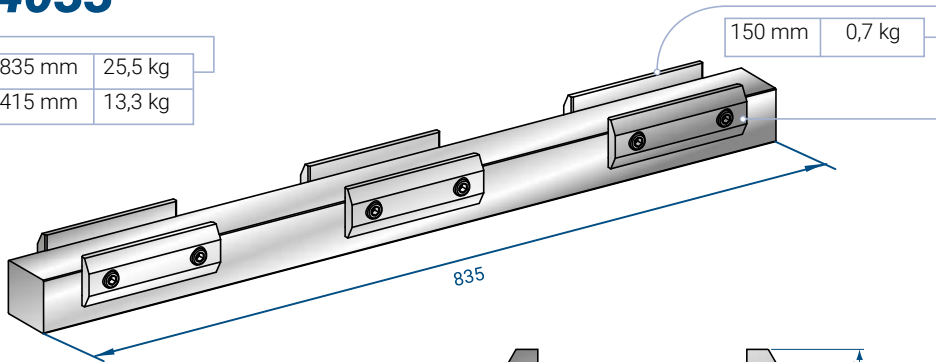

**4034**

150 mm	0,7 kg
--------	--------

**4016**

150 mm	0,6 kg
--------	--------

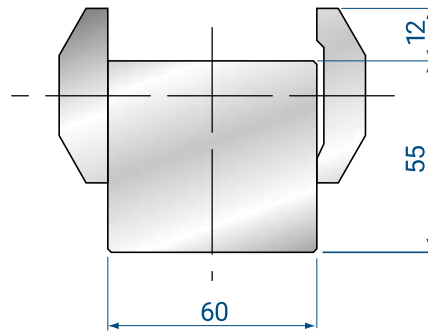

**CONTROTAVOLA  
AMADA STYLE**

AMADA STYLE  
LOWER ADAPTER

**4050**

835 mm	28,6 kg
415 mm	14,2 kg

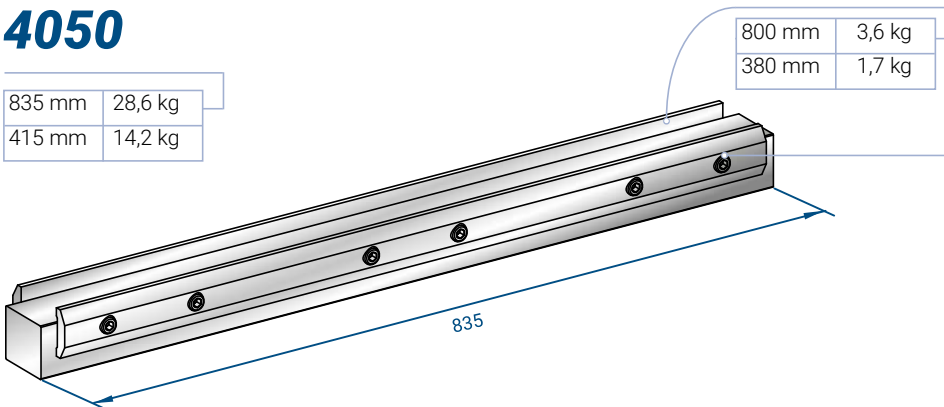

**4041**

800 mm	3,6 kg
380 mm	1,7 kg

**4040**

800 mm	3,3kg
380 mm	1,6kg

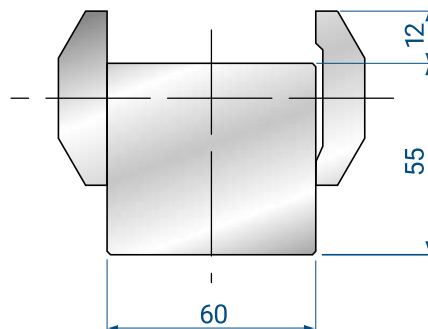

**CONTROTAVOLA  
AMADA STYLE**

AMADA STYLE  
LOWER ADAPTER

ADATTATORI PER UTENSILI INFERIORI STILE AMADA/PROMECAM  
 LOWER ADAPTERS FOR LOWER TOOLING AMADA/PROMECAM STYLE

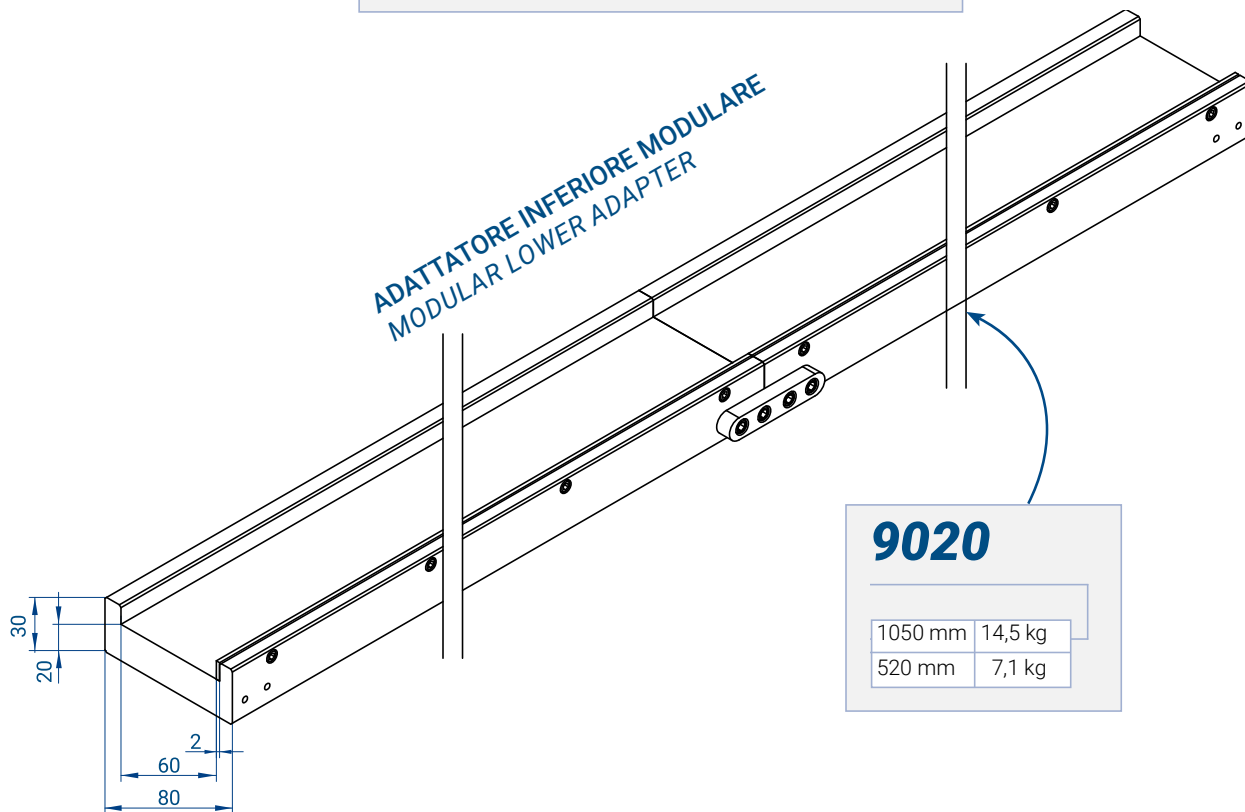
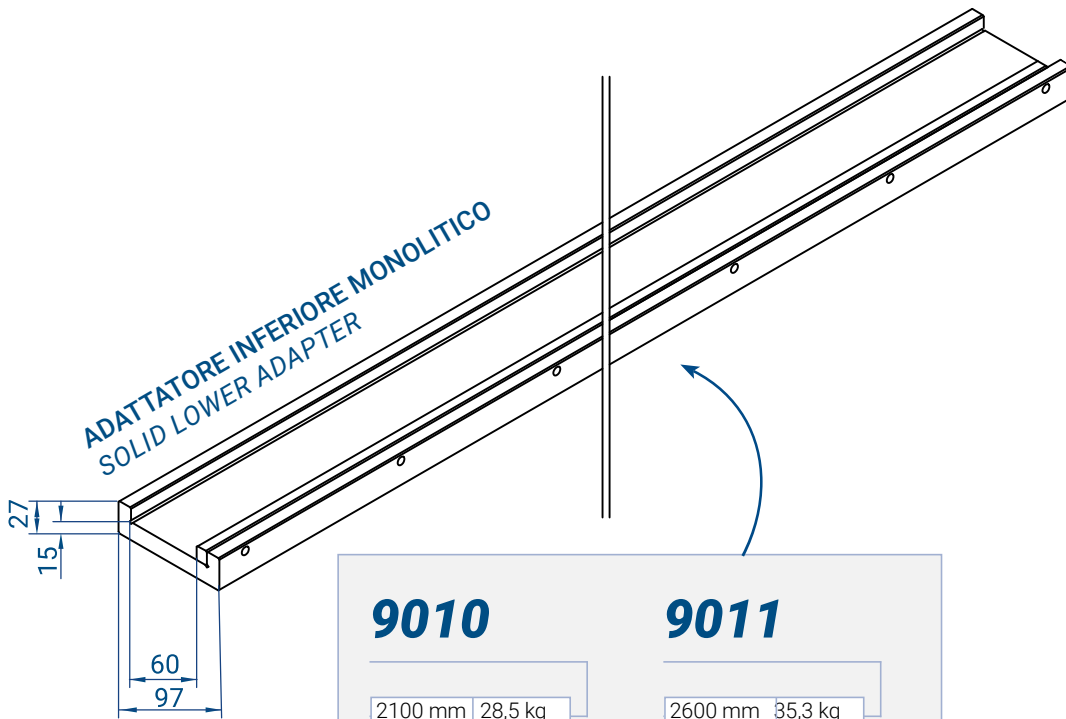

ATTACCHI SU RICHIESTA  
TANGS ON REQUEST

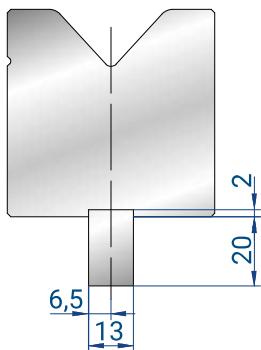

**8100**

BYSTRONIC /  
TRUMPF STYLE

832 mm	1,8 kg
412 mm	0,9 kg

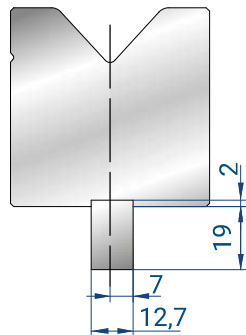

**8101**

LVD STYLE

832 mm	1,8 kg
412 mm	0,9 kg

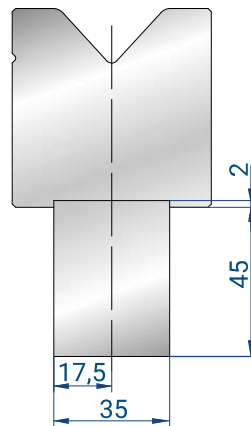

**8102**

WEINBRENNER  
STYLE

832 mm	10,5 kg
412 mm	5,2 kg

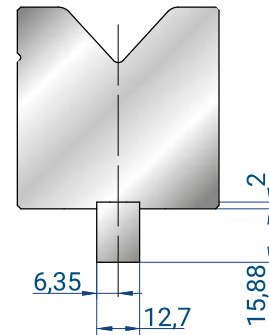

**8107**

AMERICAN  
STYLE

832 mm	1,4 kg
412 mm	0,7 kg

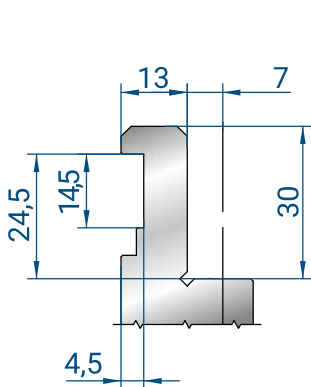

**8010**

BARRETTA  
STYLE

835 mm
415 mm
805 mm SEZIONATO

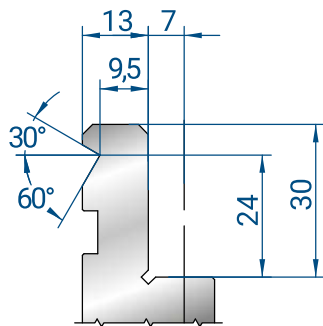

**8011**

BMB STYLE

835 mm
415 mm
805 mm SEZIONATO

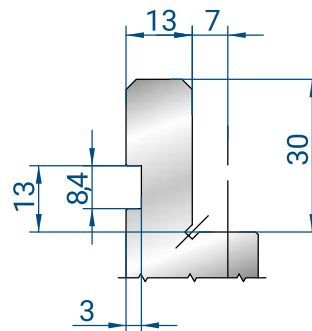

**8012**

AMADA /  
PROMECAM  
STYLE

STANDARD

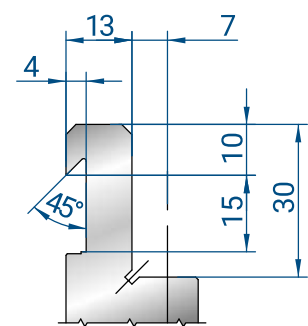

**8013**

GASPARINI  
STYLE

835 mm
415 mm
805 mm SEZIONATO

ATTACCHI SU RICHIESTA  
TANGS ON REQUEST

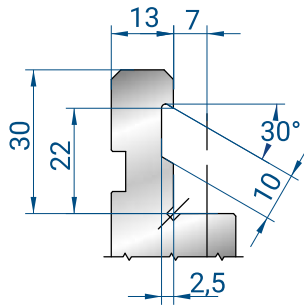

**8014**

TEDA STYLE

835 mm
415 mm
805 mm SEZIONATO

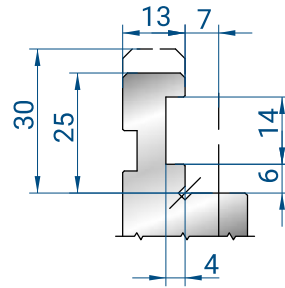

**8016**

EURO  
BYSTRONIC  
STYLE

835 mm
415 mm
805 mm SEZIONATO

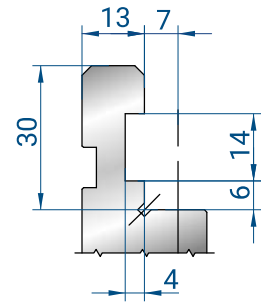

**8017**

BYSTRONIC  
STYLE

835 mm
415 mm
805 mm SEZIONATO

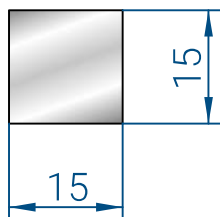

**8106**

TRAFILATI 15X15  
SQUARE BAR 15X15

835 mm	2,9 kg
--------	--------

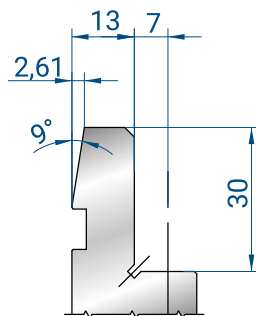

**8020**

ONE TOUCH  
STYLE

835 mm
415 mm
805 mm SEZIONATO

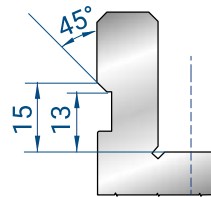

**8021**

SMART CLAMP  
STYLE

835 mm
415 mm
805 mm SEZIONATO

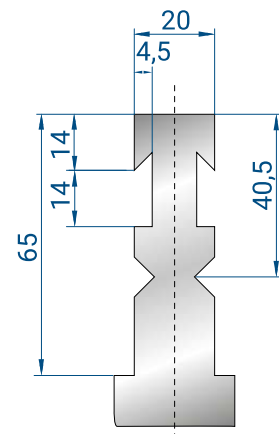

**8022**

BYSTRONIC  
RF - A STYLE

INCLUDED  
ON DEMAND

OGNI MODELLO DI MATRICE RICHIEDE UNO SPECIFICO SUPPORTO  
EACH DIE REQUIRES THE PROPER SUPPORT

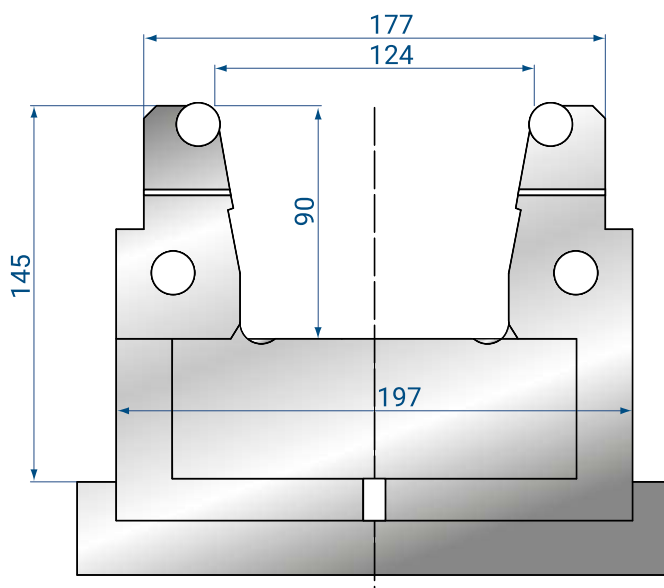
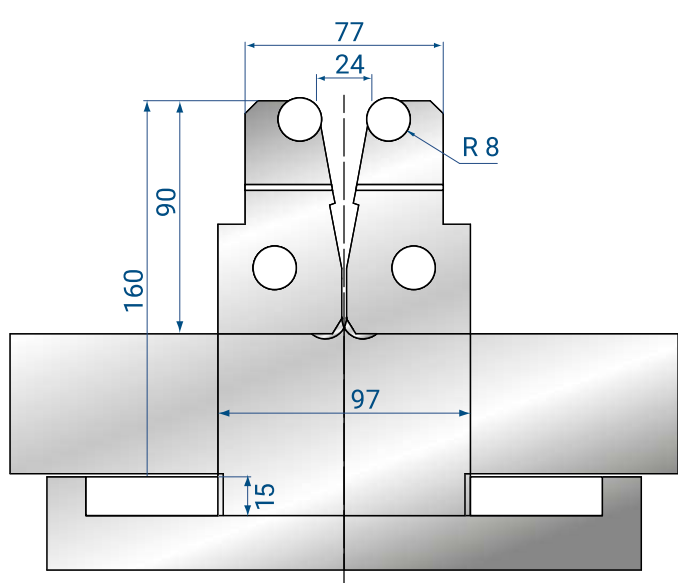

**3190**

1050 mm	133,0 kg
1000 mm	125,0 kg
550 mm	72,0 kg
500 mm	64,0 kg
250 mm	34,0kg

**Angolo minimo di piega / Minimum bend angle = 30°**

**Apertura V / V width = min 24mm – max. 124mm**

**F Max = 125 Ton/m at 90°**

#9015; #9018 (pag 253)

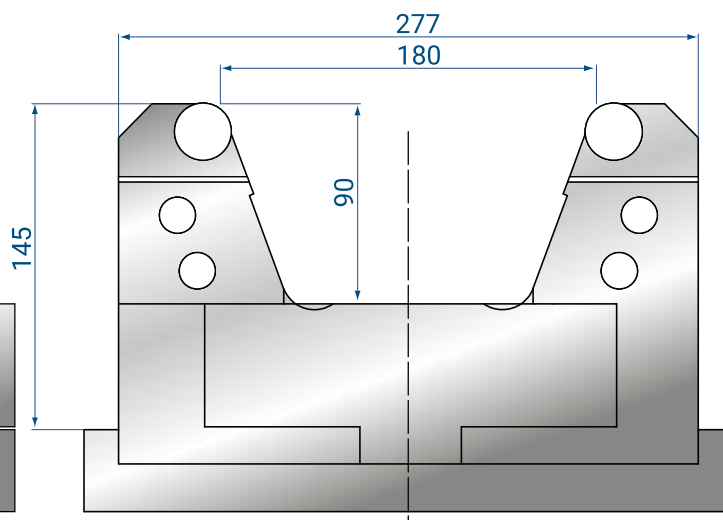
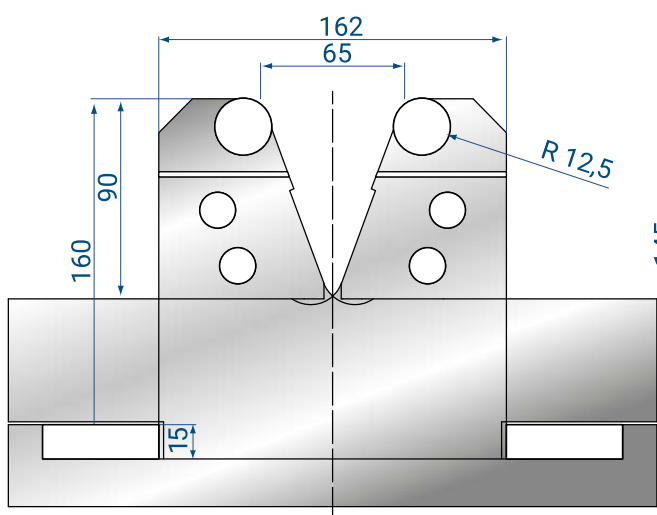

**3191**

1050 mm	180,0 kg
1000 mm	170,0 kg
550 mm	96,0 kg
500 mm	86,0 kg
250 mm	44,0kg

**Angolo minimo di piega / Minimum bend angle = 60°**

**Apertura V / V width = min 65mm – max. 180mm**

**F max = 200 Ton/m at 90°**

#9016; #9019 (pag 253)

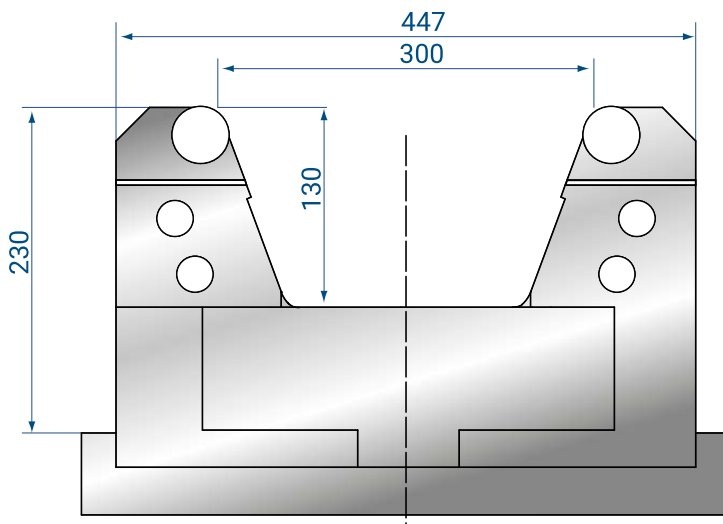
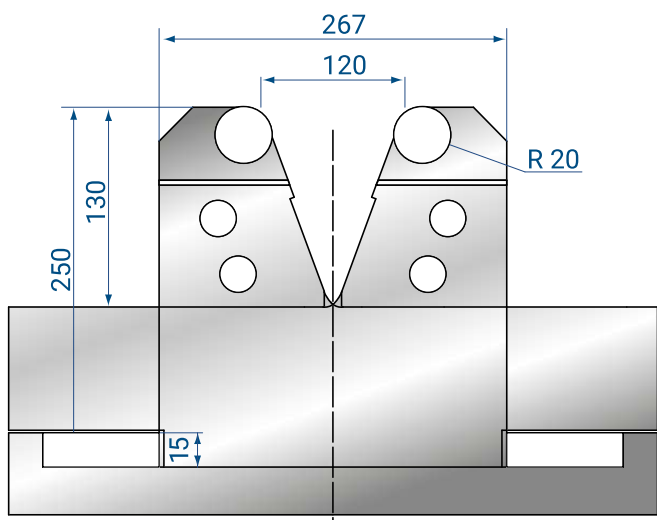

**3192**

700 mm	420 kg
600 mm	360 kg
500 mm	300 kg

**Angolo minimo di piega / Minimum bend angle = 60°**

**Apertura V / V width = min. 120mm – max. 300mm**

**F Max = 400 T/m at 90°**

#9014 (pag 253)

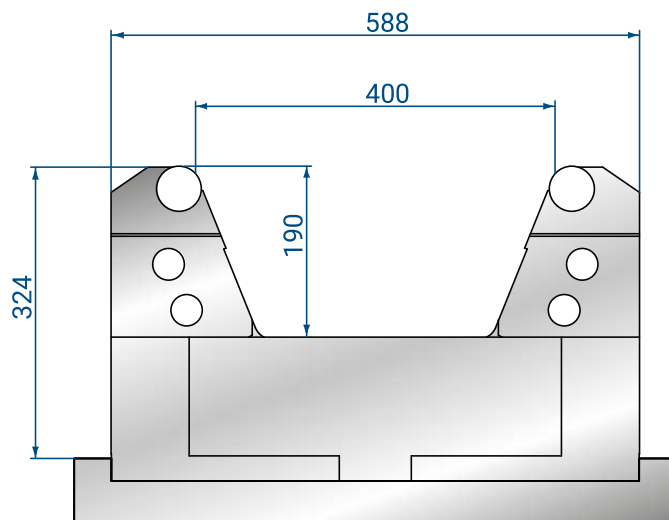
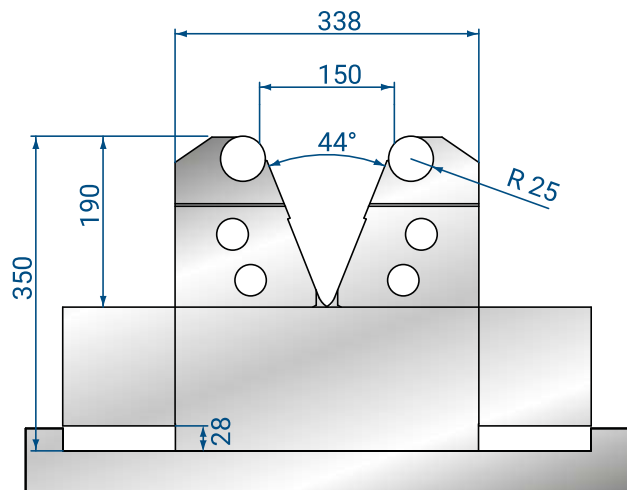

**3243**

600 mm	560,0 kg
--------	----------

**Angolo minimo di piega / Minimum bend angle = 60°**

**Apertura V / V width = min 150mm – max. 400mm**

**F Max = 600 Ton/m at 90°**

#9017 (pag 253)

# SUPPORTI INFERIORI PER MATRICI REGOLABILI LOWER HOLDER FOR ADJUSTABLE DIES

SUPPORTI SPECIFICI PER OGNI MODELLO DI MATRICE REGOLABILE  
SPECIFIC HOLDER FOR EACH ADJUSTABLE DIE HOLDER

**9015**

SU RICHIESTA / ON REQUEST

3000 mm	120 kg
2000 mm	80 kg
1000 mm	40 kg
500 mm	20 kg

PER MATRICE / FOR DIE  
**3190**

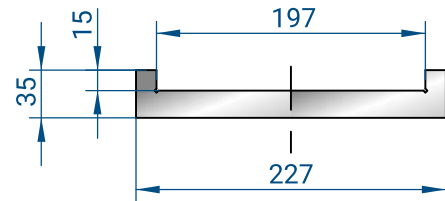

**9018**

SPECIFICO PER ATTACCO WILA / TRUMPF  
WILA / TRUMPF DEDICATED TANG

**9016**

SU RICHIESTA / ON REQUEST

3000 mm	318 kg
2000 mm	212 kg
1000 mm	106 kg
500 mm	53 kg

PER MATRICE / FOR DIE  
**3191**

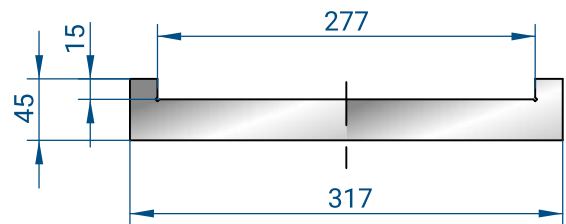

**9019**

SPECIFICO PER ATTACCO WILA / TRUMPF  
WILA / TRUMPF DEDICATED TANG

**9014**

SU RICHIESTA / ON REQUEST

3000 mm	594 kg
2400 mm	396 kg
1200 mm	198 kg
600 mm	99 kg

PER MATRICE  
FOR DIE  
**3192**

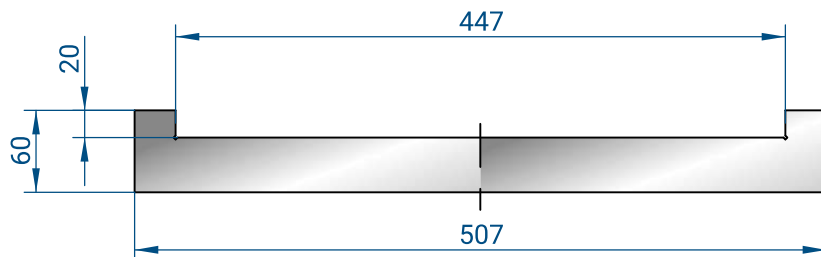

**9017**

SU RICHIESTA / ON REQUEST

3000 mm	900 kg
2400 mm	600 kg
1200 mm	300 kg
600 mm	150 kg

PER MATRICE  
FOR DIE  
**3243**

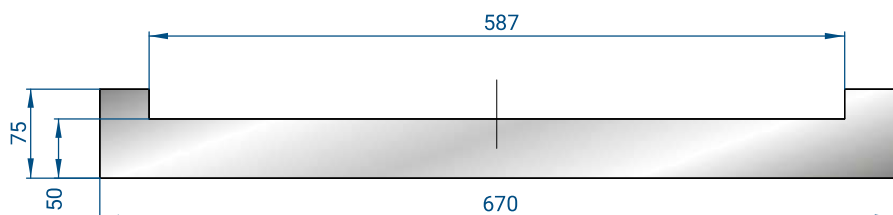

PROTEZIONE DALLE MARCATURE  
PROTECTION AGAINST MARKS



COPPIA DI SUPPORTI PER PELLICOLE / TESSUTI  
PROTETTIVI  
COUPLE OF SUPPORT FOR PROTECTIVE SHEET / FABRIC

**4309**

2,6 kg



PELLICOLA DI POLIURETANO ANTIGRAFFIO  
SCRATCH-RESISTANT POLYURETHANE FILM

**4308**

Spessore / *thickness* = 0,5 mm  
Larghezza / *width* = 105 mm  
Lunghezza / *length* = 33 m  
Peso / *weight* = 1,7 kg

**4314**

Spessore / *thickness* = 0,8 mm  
Larghezza / *width* = 95 mm  
Lunghezza / *length* = 33 m  
Peso / *weight* = 2,7 kg



TESSUTO PROTETTIVO PER PREVENIRE E  
RIDURRE ENTITÀ DI MARCATURE SU LAMIERA  
PROTECTIVE FABRIC FOR AVOIDING / LIMITING  
THE ENTITY OF MARKS OF THE SHEET METAL

**4379**

L = 5 m / 0,4 kg  
L = 10 m / 0,8 kg  
Spessore / *thickness* = Max 3 mm



**4380**

L = 5 m / 0,4 kg  
L = 10 m / 0,8 kg  
Spessore / *thickness* = Max 6 mm



COMPLEMENTI AUSILIARI  
AUXILIARY COMPLEMENTS

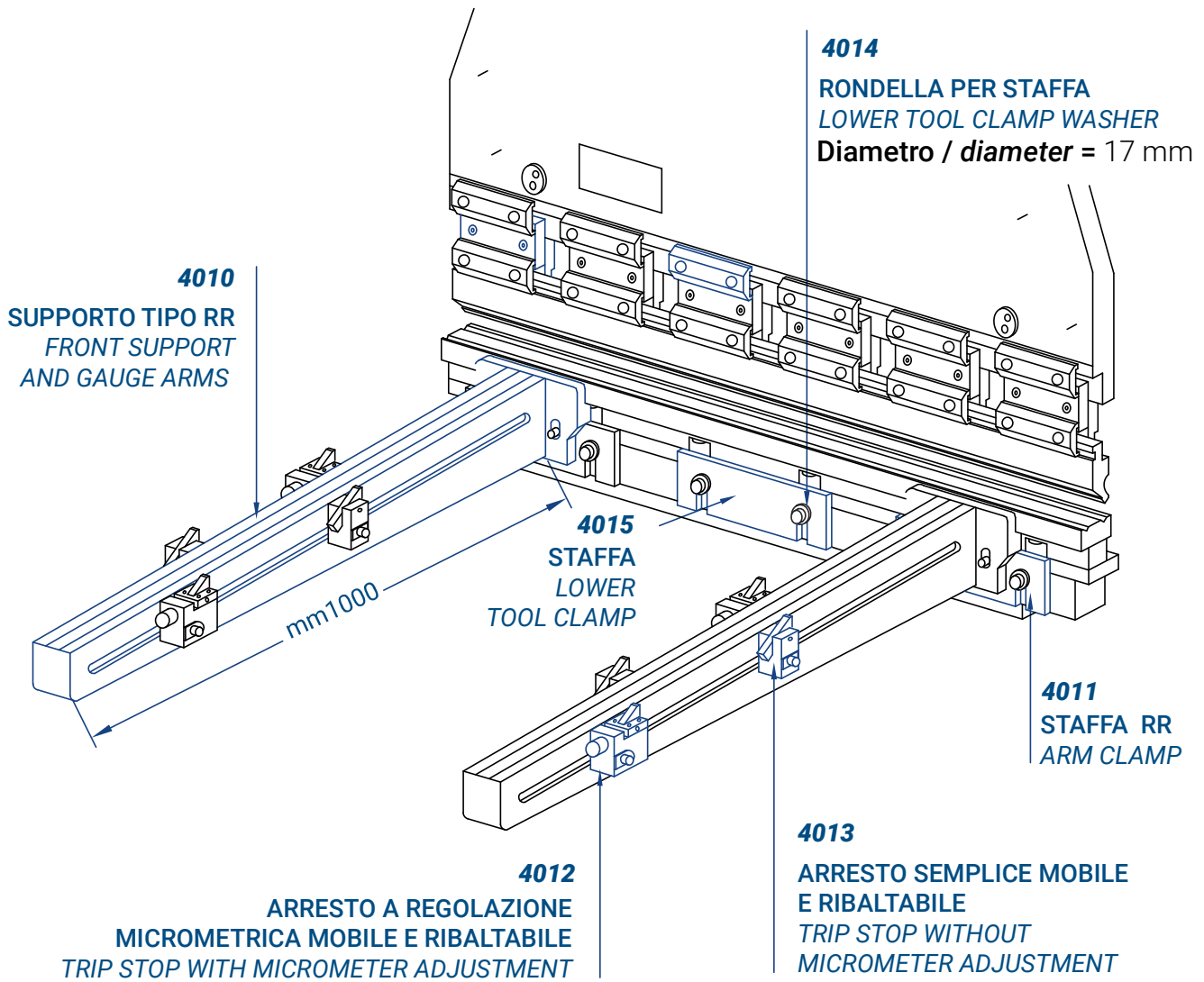

**4306**

SQUADRE DI RIFERIMENTO  
REFERENCE SQUARES

3,0 kg



**4307**

SQUADRE DI RIFERIMENTO ORIENTABILI  
ADJUSTSABLE REFERENCE SQUARES

3,5 kg

**4318**

SQUADRETTA DI RIFERIMENTO  
MAGNETICA SINISTRA  
MAGNETIC SQUARING ARM - LEFT



**4319**

SQUADRETTA DI RIFERIMENTO  
MAGNETICA DESTRA  
MAGNETIC SQUARING ARM - RIGHT



GONIOMETRO MANUALE / MANUAL PROTRACTOR

GONIOMETRO MANUALE PER LA  
MISURAZIONE DI ANGOLI INTERNI ED  
ESTERNI CON LA MINIMA INTERFERENZA

MANUAL PROTRACTOR FOR MEASURING  
INTERNAL AND EXTERNAL ANGLES WITHOUT  
INTERFERENCE



**4883**

TRIPLA MODALITÀ DI LETTURA  
THREE SETS OF READING

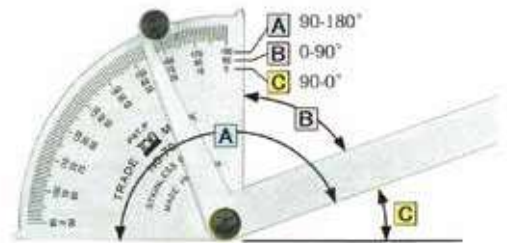

PRECISIONE ACCURACY	DIMENSIONI DIMENSIONS	UNITÀ GRADUATION	MATERIALE MATERIAL
+/- 0,2°	L = 255 mm H = 80 mm	1°	ACCIAIO INOX 1,2 mm

MODALITÀ DI UTILIZZO  
HOW TO USE

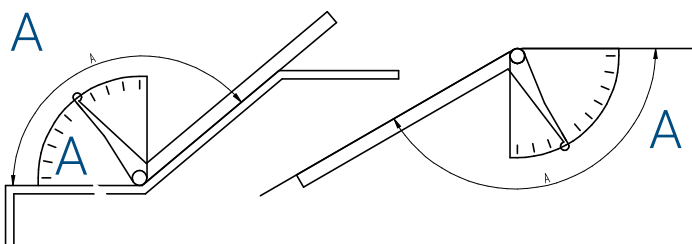

MISURA ANGOLO INTERNO  
INTERNAL ANGLE MEASUREMENT

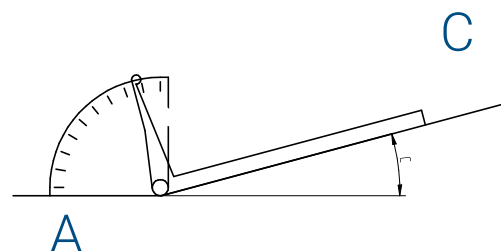

MISURA ANGOLO ESTERNO  
OUTSIDE ANGLE MEASUREMENT

**CALIBRO DIGITALE PER LA MISURA DI SMUSSI A 45° E DI RAGGI**  
*DIGITAL GAUGE FOR 45° CHAMFERS AND RADIUS*

**4384**



Utilizzabile per misurare le dimensioni di smussi a 45° e di raggi.  
Il pulsante C/R commuta fra misura di smusso (c) e di raggio (r).  
Possibilità di effettuare misure assolute e relative.  
Definizione del punto 0 in qualsiasi posizione.  
Pezzo campione  $\varnothing$  20 mm per calibrazione compreso nella confezione.

---

*Measures a small 45° chamfer and radius.  
The C/R toggles between chamfer and radius measurement.  
Absolute and relative measurement functions are available.  
Zero setting at any point.  
Setting master pin gauge for calibration included.*

<b>MISURAZIONE</b> <i>MEASUREMENT</i>	Smusso a 45° su angolo retto; raggio esterno di piegatura. <i>45° chamfer on a square corner; outer corner radius.</i>	
<b>GAMMA DI MISURAZIONE</b>  <i>MEASUREMENT RANGE</i>	Smusso su angoli 45° (C) Raggio su angoli 90° (R) Raggio su angoli acuti ≤ 89° (R)	0,01 - 15,00 mm 0,01 - 25,00 mm 0,06 - 25,00 mm
	<i>Chamfer on angle 45° (C)</i> <i>Radius on angle 90° (R)</i> <i>Radius on acute angles ≤ 89° (R)</i>	<i>0,01 - 15,00 mm</i> <i>0,01 - 25,00 mm</i> <i>0,06 - 25,00 mm</i>
<b>RISOLUZIONE</b> <i>RESOLUTION</i>	0,01 mm	
<b>TOLLERANZA</b> <i>ACCURACY</i>	Smussi = +/- 0,05mm <i>Chamfer = +/- 0,05mm</i>	Raggi= +/- 0,08mm <i>Radius= +/- 0,08mm</i>
<b>MATERIALE</b> <i>MATERIAL</i>	Acciaio inox <i>Stainless steel</i>	



## ARMADI PORTA UTENSILI TOOLING CABINETS

COLORE STANDARD NERO, PIÙ OPZIONI COLORI A RICHIESTA  
STANDARD COLOUR BLACK, MORE COLOR OPTIONS ON REQUEST



CODICE CODE	STILE STYLE	ANTE DRAWERS	LUNGHEZZA LENGTH (mm)
ACARM0NE0005	Amada	5	835
ACARM1NE0005	Trumpf / Wila / Bystronic / LVD	5	1100
ACARM2NE0005	Trumpf / Wila / Bystronic / LVD	5	550

DISPONIBILI SU RICHIESTA ARMADI A 3 O 4 ANTE  
AVAILABLE ON REQUEST WARDROBES WITH 3 OR 4 DOORS



CODICE CODE	STILE STYLE	ANTE DRAWERS	LUNGHEZZA LENGTH (mm)
CARRELLO0005	Carrello mobile per utensili Amada 5 ripiani - L= 835 mm  Mobile trolley for Amada tools 5 shelves - L= 835 mm		



MATRICI MULTICAVA A RICHIESTA  
MULTI V DIES ON REQUEST

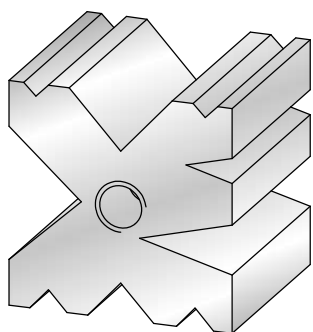

**MATERIALI**  
MATERIALS

1.2312  
C45  
42CrM04

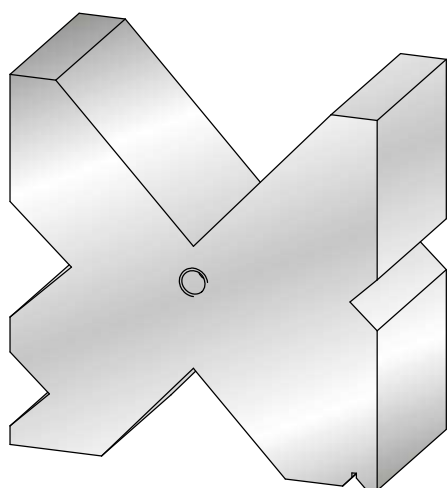
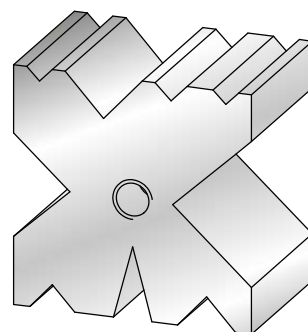

**LAVORAZIONI**  
PROCESSING

Temprato / *Hardened*  
Bonificato nitrurato /  
*Tempered - nitrided*  
Piallato / *Planed*  
Rettificato / *Ground*

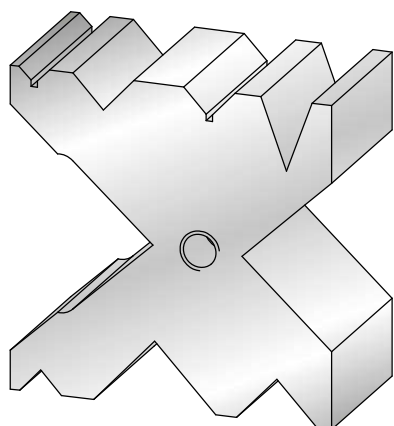
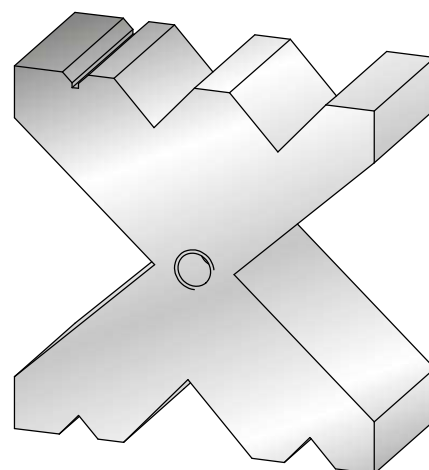

**LUNGHEZZE**  
LENGTHS (MM)

2000  
3000  
4000  
6000  
8000

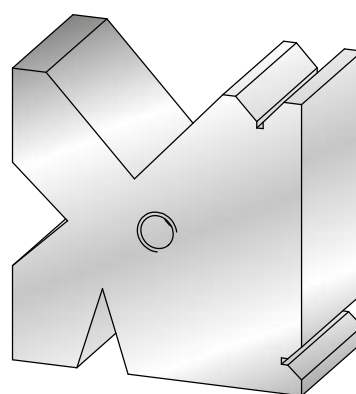

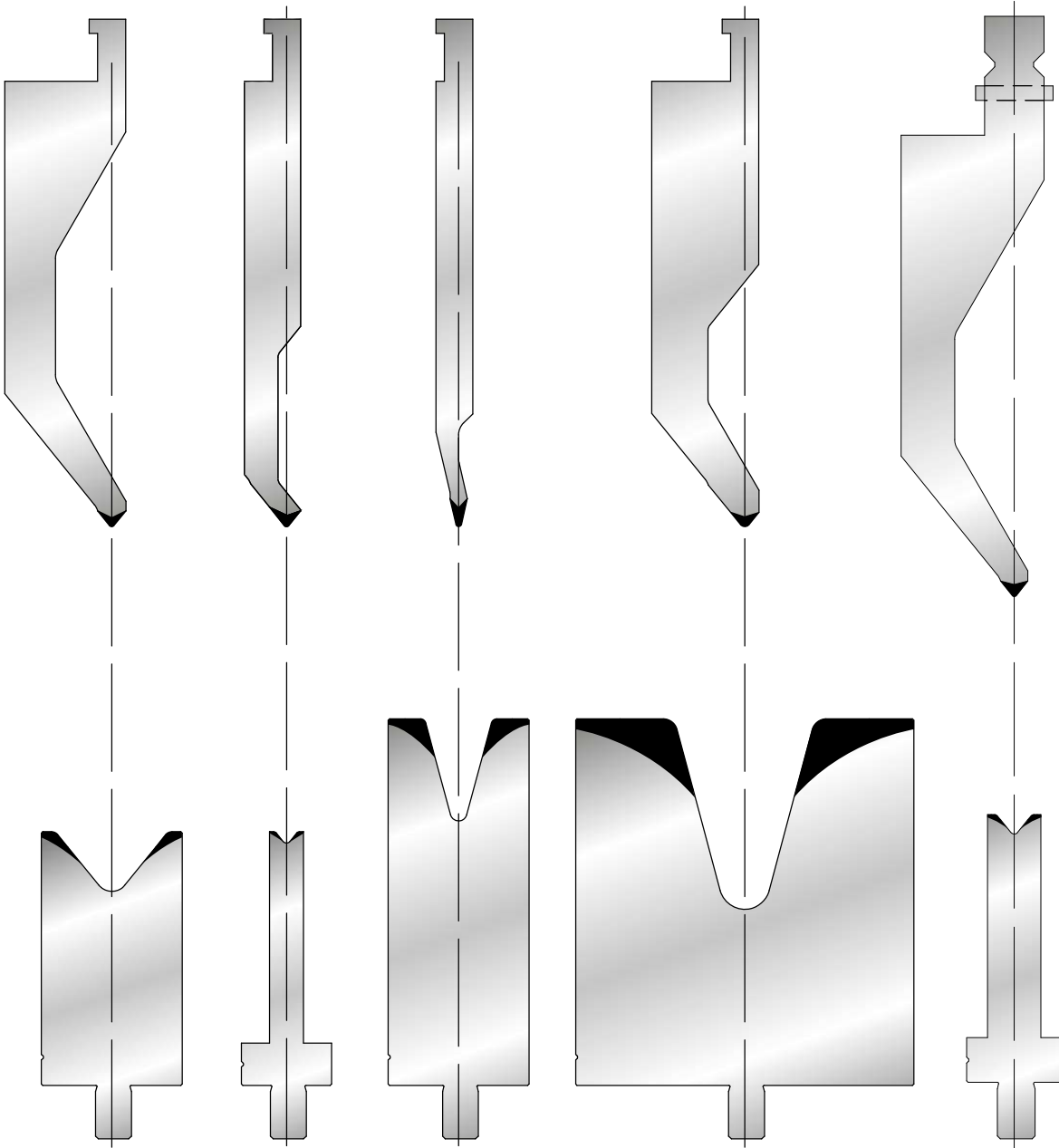

LVD Style

LVD Wila Style

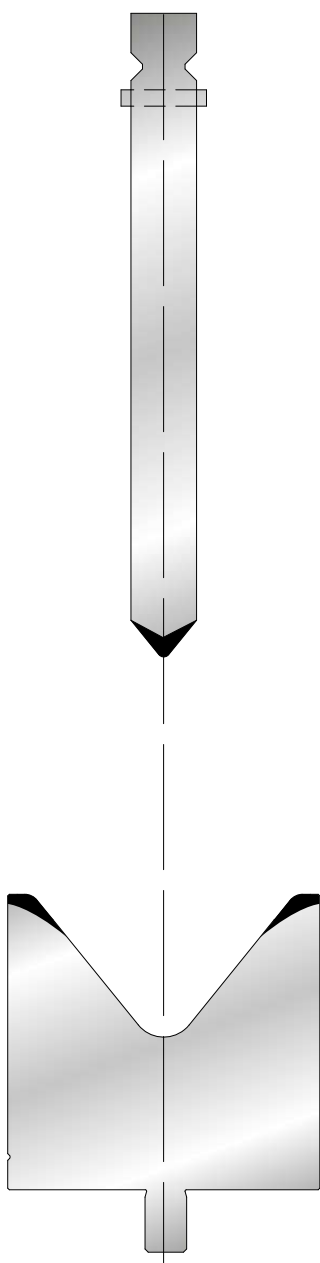

LVD - Wila Style

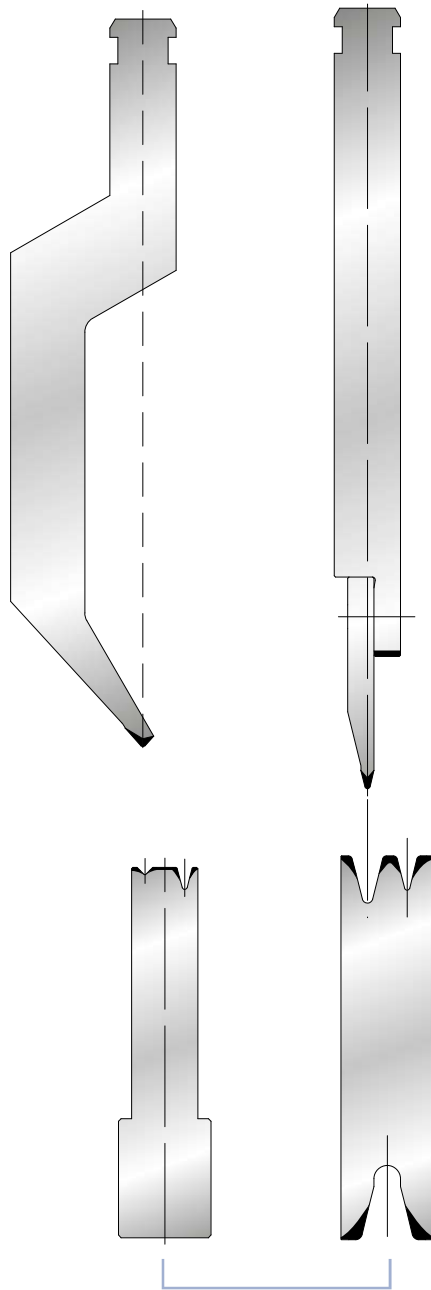

Weinbrenner Style

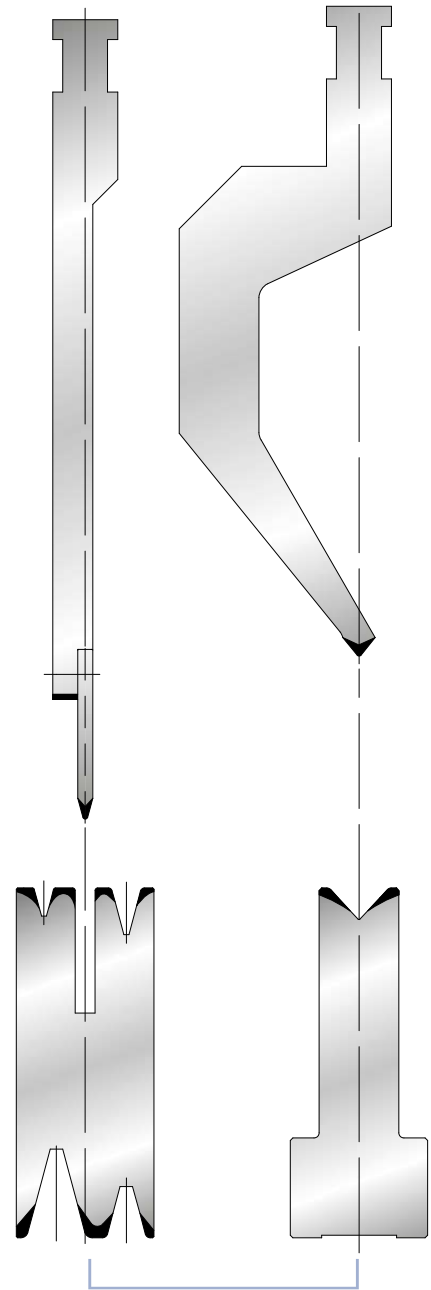

EHT Style

UTENSILI SPECIALI SU RICHIESTA  
SPECIAL TOOLS ON REQUEST

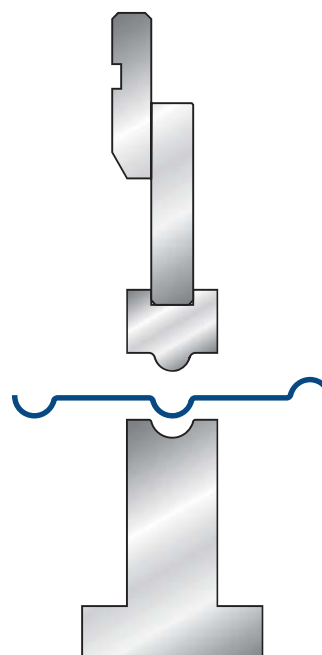
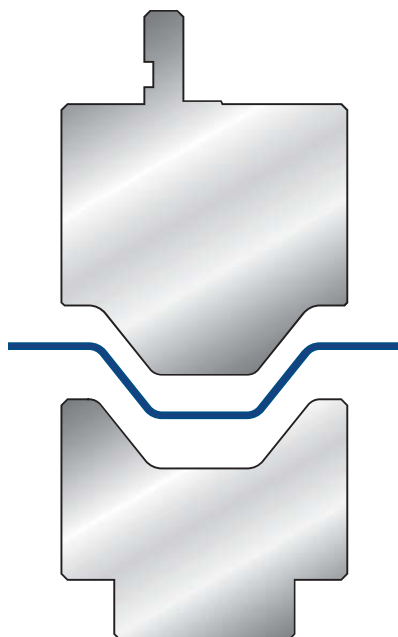
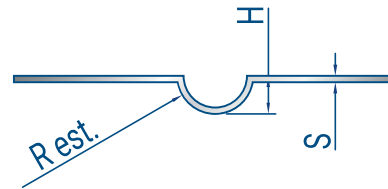
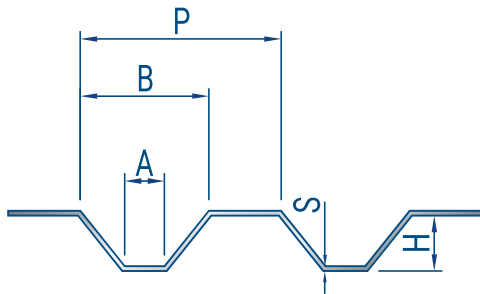
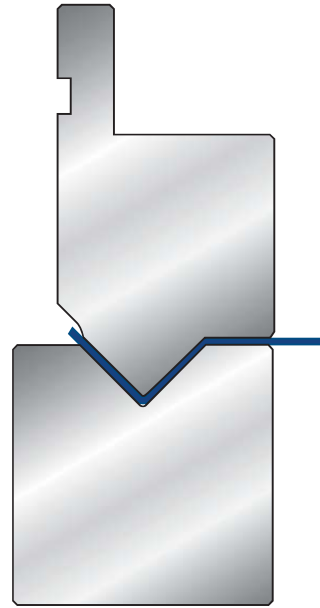
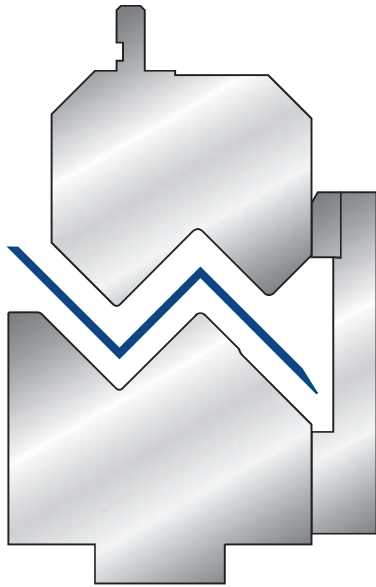
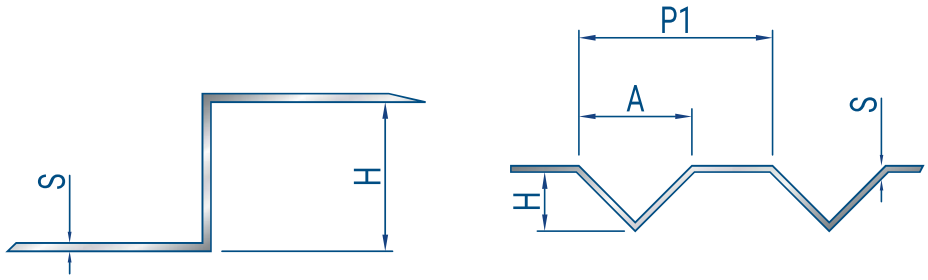

UTENSILI SPECIALI SU RICHIESTA  
SPECIAL TOOLS ON REQUEST

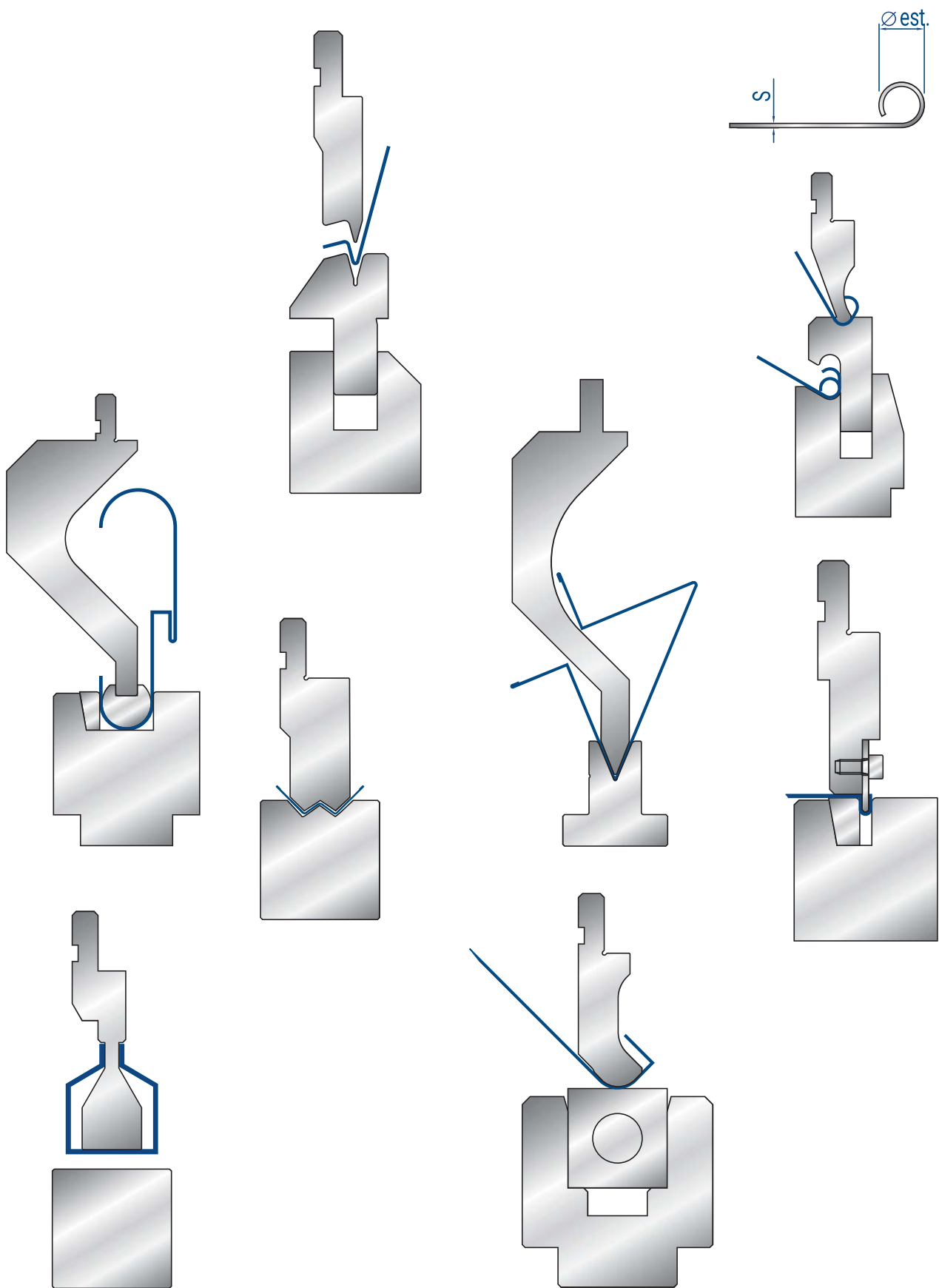

**MATERIALE TAGLIATO / CUT MATERIAL:**

- Alluminio / Aluminium**
- Ferro / Mild steel**
- Acciaio inossidabile / Stainless steel**
- Altro materiale / Other material:**
- .....

**MOD**.....

**PR**.....

<b>QUOTA</b> <i>DIMENSION</i>	<b>MISURA (mm)</b> <i>MEASURE (mm)</i>
A	
B	
C	
D	
E	
F	
H	
I	
K	
L	
<b>N° fori / N° holes</b>	

**PROFILO / PROFILE**

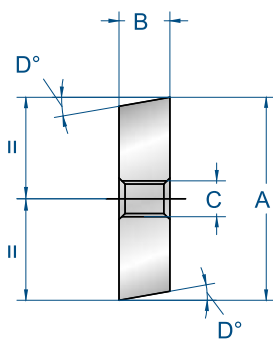
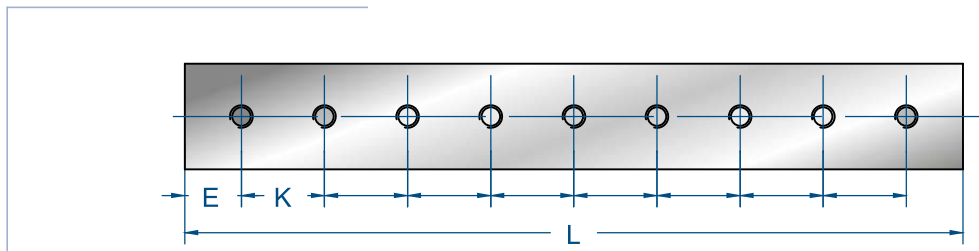

**mod. 2000**

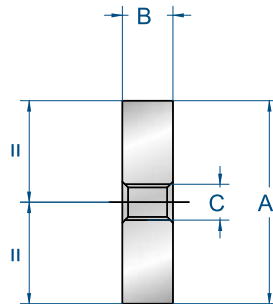

**mod. 2001**

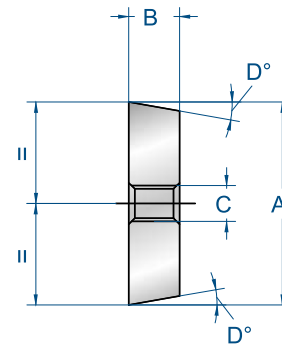

**mod. 2002**

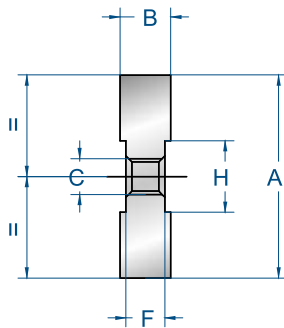

**mod. 2003**

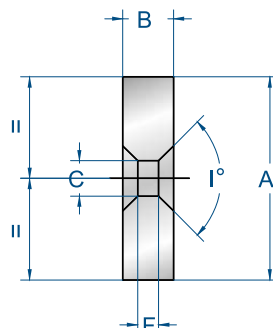

**mod. 2004**

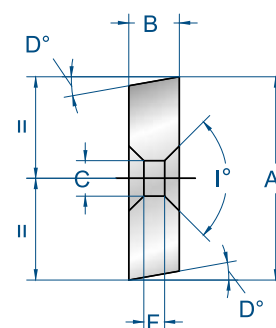

**mod. 2005**



## 8201

### FOSFATAZIONE

Trattamento superficiale che aumenta la resistenza alla corrosione.

### PHOSPHATING TREATMENT

Surface treatment able to increase the corrosion resistance.

## 8205

### NITRURAZIONE

Trattamento di indurimento superficiale che aumenta la resistenza all'usura, alla fatica e agli intagli.

### NITRIDING TREATMENT

Surface hardening treatment able to increase the tool resistance to wear, to fatigue, to notches.

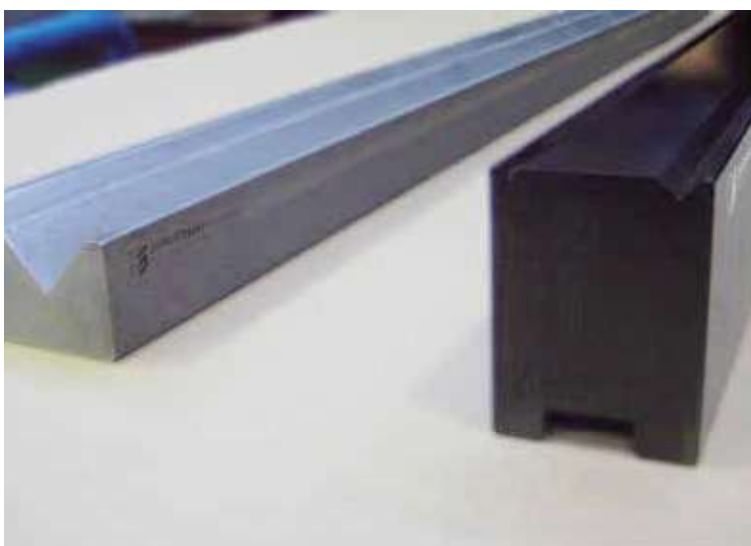

## 8202

### NITRURAZIONE + FOSFATAZIONE

Indurimento superficiale + resistenza alla corrosione.

### NITRIDING TREATMENT + PHOSPHATING

Surface hardening + corrosion resistance.





**EUROSTAMP** TOOLING  
the Italian excellence



**EUROSTAMP** TOOLING  
the Italian excellence

---

Via dell'Industria 11  
29010 Gagnano Trebbiense  
(PC-ITALY)

---

Tel. +39 0523 489 954  
Tel. +39 0523 499 254  
Fax +39 0523 400 490  
[info@eurostampsrl.it](mailto:info@eurostampsrl.it)  
[www.eurostampsrl.it](http://www.eurostampsrl.it)